

# GEX 125-1 A Professional GEX 125-1 AE Professional



**pt-BR** Manual de instruções  
**es** Instrucciones de servicio  
**en** Operating instructions



## Certificado de Garantia\*

GEX 125-1A (3•601•C87 0..) / GEX 125-1AE(3 601 C87 5..)

Nome do comprador	Série nº
Endereço	Tipo nº
Data da venda	Nota fiscal
Nome do vendedor	Carimbo da firma

### Prescrições de garantia

1. As ferramentas elétricas são garantidas contra eventuais defeitos de montagem ou de fabricação devidamente comprovados.
2. Esta garantia é válida por 12 meses, contados a partir da data de fornecimento ao usuário, sendo 3 meses o prazo de garantia legal (CDC) e mais 9 meses concedidos pelo fabricante.
3. Dentro do período de garantia, as peças ou componentes que comprovadamente apresentarem defeitos de fabricação serão consertados ou, conforme o caso, substituídos gratuitamente por qualquer Oficina Autorizada Bosch, contra a apresentação do "Certificado de Garantia" preenchido e/ou da fatura respectiva.

### Não estão incluídos na garantia

4. Os defeitos originados de:
  - 4.1 uso inadequado da ferramenta;
  - 4.2 instalações elétricas deficientes;
  - 4.3 ligação da ferramenta elétrica em rede elétrica inadequada;
  - 4.4 desgaste natural;
  - 4.5 desgaste oriundo de intervalos muito longos entre as revisões;
  - 4.6 estocagem incorreta, influência do clima etc.

### Cessa a garantia

5. Se o produto for modificado ou aberto por terceiros; se tiverem sido montadas peças fabricadas por terceiros; ou, ainda, se o produto tiver sido consertado por pessoas não autorizadas.
6. Se a máquina for aberta enquanto ainda se encontrar em período de garantia.

\* Este certificado de garantia é válido somente para o Brasil.



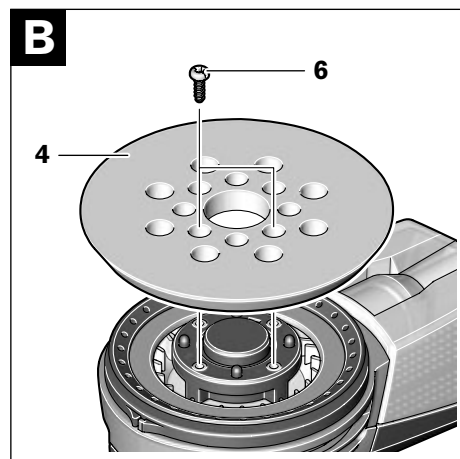
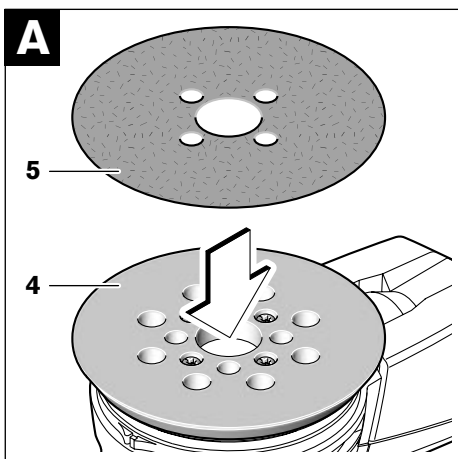
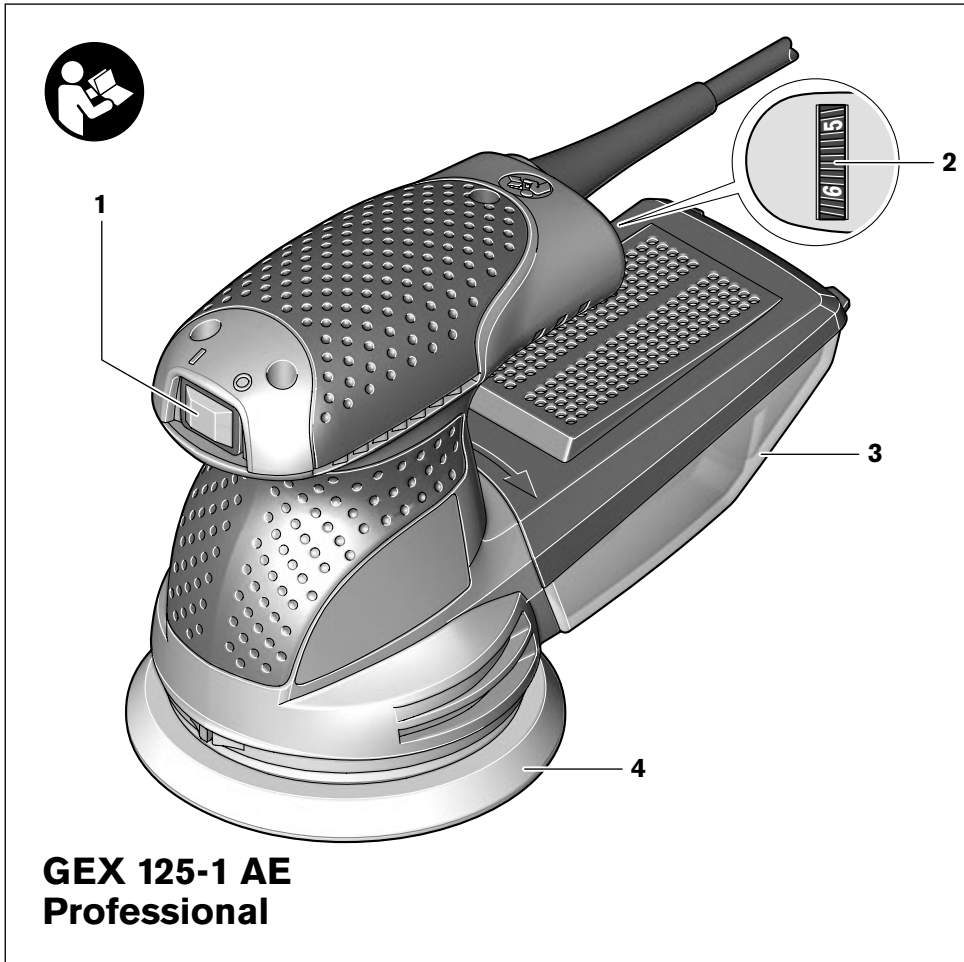

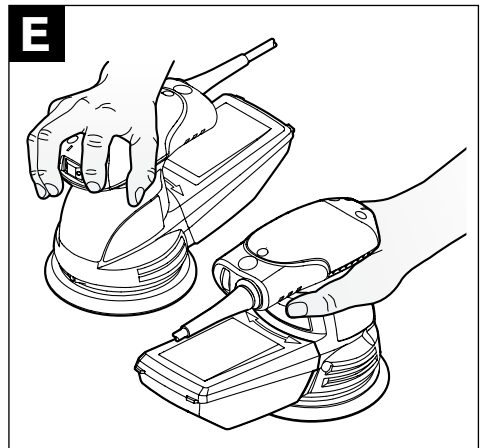
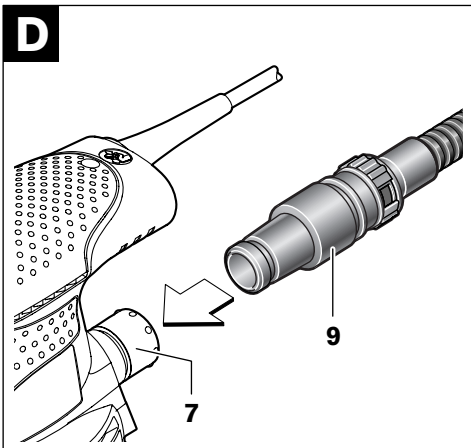
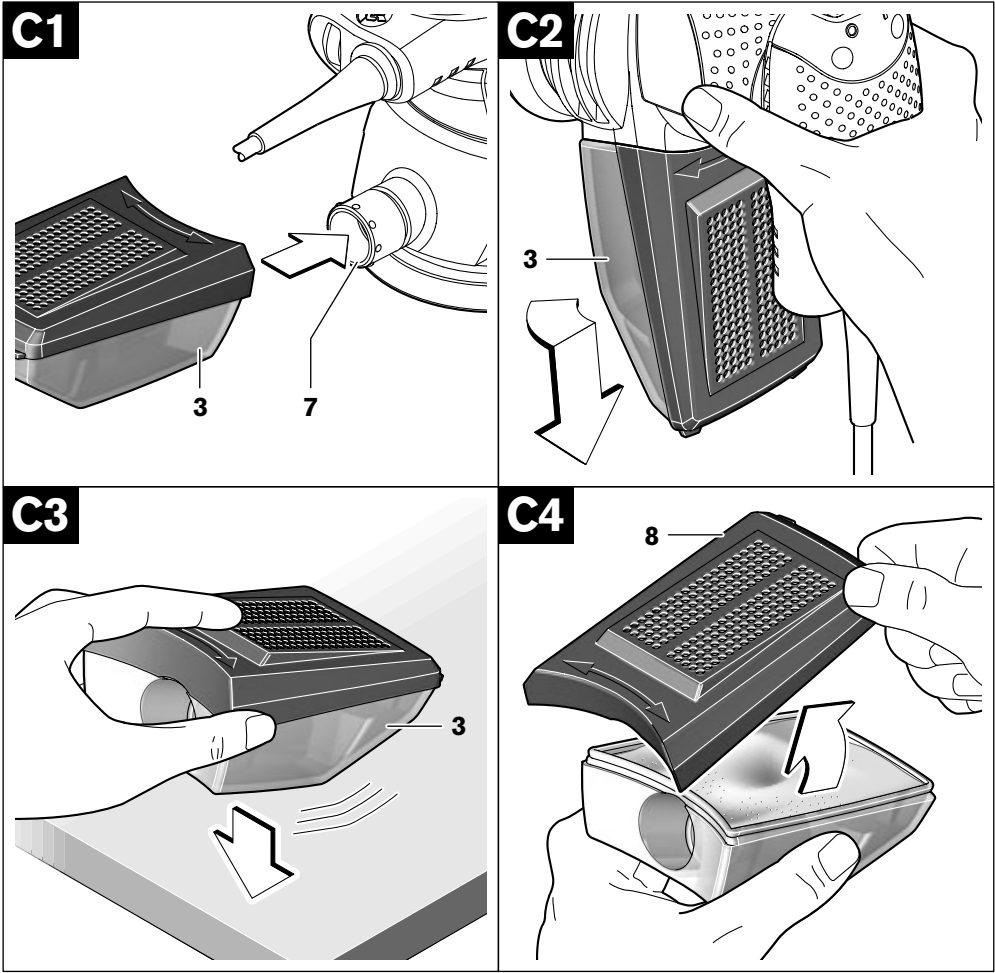

## General Power Tool Safety Warnings

**⚠ WARNING** Read all safety warnings and all instructions. Failure to follow the warnings and instructions may result in electric shock, fire and/or serious injury.

**Save all warnings and instructions for future reference.**

The term "power tool" in the warnings refers to your mains-operated (corded) power tool or battery-operated (cordless) power tool.

### 1) Work area safety

- a) **Keep work area clean and well lit.** Cluttered or dark areas invite accidents.
- b) **Do not operate power tools in explosive atmospheres, such as in the presence of flammable liquids, gases or dust.** Power tools create sparks which may ignite the dust or fumes.
- c) **Keep children and bystanders away while operating a power tool.** Distractions can cause you to lose control.

### 2) Electrical safety

- a) **Power tool plugs must match the outlet. Never modify the plug in any way. Do not use any adapter plugs with earthed (grounded) power tools.** Unmodified plugs and matching outlets will reduce risk of electric shock.
- b) **Avoid body contact with earthed or grounded surfaces, such as pipes, radiators, ranges and refrigerators.** There is an increased risk of electric shock if your body is earthed or grounded.
- c) **Do not expose power tools to rain or wet conditions.** Water entering a power tool will increase the risk of electric shock.
- d) **Do not abuse the cord. Never use the cord for carrying, pulling or unplugging the power tool. Keep cord away from heat, oil, sharp edges and moving parts.** Damaged or entangled cords increase the risk of electric shock.
- e) **When operating a power tool outdoors, use an extension cord suitable for outdoor use.** Use of a cord suitable for outdoor use reduces the risk of electric shock.
- f) **If operating a power tool in a damp location is unavoidable, use a residual current device (RCD) protected supply.** Use of an RCD reduces the risk of electric shock.

### 3) Personal safety

- a) **Stay alert, watch what you are doing and use common sense when operating a power tool. Do not use a power tool while you are tired or under the influence of drugs, alcohol or medication.** A moment of inattention while operating power tools may result in serious personal injury.
- b) **Use personal protective equipment. Always wear eye protection.** Protective equipment such as dust mask, non-skid safety shoes, hard hat, or hearing protection used for appropriate conditions will reduce personal injuries.
- c) **Prevent unintentional starting. Ensure the switch is in the off-position before connecting to power source and/or battery pack, picking up or carrying the tool.** Carrying power tools with your finger on the switch or energising power tools that have the switch on invites accidents.
- d) **Remove any adjusting key or wrench before turning the power tool on.** A wrench or a key left attached to a rotating part of the power tool may result in personal injury.
- e) **Do not overreach. Keep proper footing and balance at all times.** This enables better control of the power tool in unexpected situations.
- f) **Dress properly. Do not wear loose clothing or jewellery. Keep your hair, clothing and gloves away from moving parts.** Loose clothes, jewellery or long hair can be caught in moving parts.
- g) **If devices are provided for the connection of dust extraction and collection facilities, ensure these are connected and properly used.** Use of dust collection can reduce dust-related hazards.

### 4) Power tool use and care

- a) **Do not force the power tool. Use the correct power tool for your application.** The correct power tool will do the job better and safer at the rate for which it was designed.
- b) **Do not use the power tool if the switch does not turn it on and off.** Any power tool that cannot be controlled with the switch is dangerous and must be repaired.
- c) **Disconnect the plug from the power source and/or the battery pack from the power tool before making any adjustments, changing accessories, or storing power tools.** Such preventive safety measures reduce the risk of starting the power tool accidentally.

- d) **Store idle power tools out of the reach of children and do not allow persons unfamiliar with the power tool or these instructions to operate the power tool.** Power tools are dangerous in the hands of untrained users.
- e) **Maintain power tools. Check for misalignment or binding of moving parts, breakage of parts and any other condition that may affect the power tool's operation. If damaged, have the power tool repaired before use.** Many accidents are caused by poorly maintained power tools.
- f) **Keep cutting tools sharp and clean.** Properly maintained cutting tools with sharp cutting edges are less likely to bind and are easier to control.
- g) **Use the power tool, accessories and tool bits etc. in accordance with these instructions, taking into account the working conditions and the work to be performed.** Use of the power tool for operations different from those intended could result in a hazardous situation.

#### 5) Service

- a) **Have your power tool serviced by a qualified repair person using only identical replacement parts.** This will ensure that the safety of the power tool is maintained.

## Machine-specific Safety Warnings

- ▶ **Use the machine only for dry sanding.** Penetration of water into the machine increases the risk of an electric shock.
- ▶ **Pay attention that no persons are put at risk through sparking. Remove any combustible materials in the vicinity.** Sparking occurs when sanding metal materials.
- ▶ **Caution, fire hazard! Avoid overheating the object being sanded as well as the sander. Always empty the dust collector before taking breaks.** In unfavourable conditions, e.g., when sparks emit from sanding metals, sanding debris in the dust bag, micro filter or paper sack (or in the filter sack or filter of the vacuum cleaner) can self-ignite. Particularly when mixed with remainders of varnish, polyurethane or other chemical materials and when the sanding debris is hot after long periods of working.
- ▶ **Secure the workpiece.** A workpiece clamped with clamping devices or in a vice is held more secure than by hand.

- ▶ **Do not work materials containing asbestos.** Asbestos is considered carcinogenic.
- ▶ **Take protective measures when dust can develop during working that is harmful to one's health, combustible or explosive.** Example: Some dusts are regarded as carcinogenic. Wear a dust mask and work with dust/chip extraction when connectable.
- ▶ **Keep your workplace clean.** Blends of materials are particularly dangerous. Dust from light alloys can burn or explode.
- ▶ **Never use the machine with a damaged cable. Do not touch the damaged cable and pull the mains plug when the cable is damaged while working.** Damaged cables increase the risk of an electric shock.

## Functional Description



**Read all safety warnings and all instructions.** Failure to follow the warnings and instructions may result in electric shock, fire and/or serious injury.

While reading the operating instructions, unfold the graphics page for the machine and leave it open.

### Intended Use

The machine is intended for dry sanding of wood, plastic, metal, filler as well as coated surfaces. Machines with electronic control are also suitable for polishing.

### Product Features

The numbering of the product features refers to the illustration of the machine on the graphics page.

- 1 On/Off switch
- 2 Thumbwheel for speed preselection (GEX 125-1 AE)
- 3 Dust box, complete (micro filtersystem)
- 4 Sanding plate
- 5 Sanding sheet\*
- 6 Screws for sanding plate
- 7 Extraction outlet
- 8 Filter element (micro filtersystem)
- 9 Vacuum hose\*

\*The accessories illustrated or described are not included as standard delivery.

## Technical Data

Random Orbital Sander		GEX 125-1 A Professional	GEX 125-1 AE Professional
Article number		3 601 C87 0..	3 601 C87 5..
Rated power input	W	250	250
Preselection of orbital stroke rate		–	●
No-load speed	rpm	12000	7500–12000
Orbital stroke rate	opm	24000	15000–24000
Orbit diameter	mm	2.5	2.5
Sanding plate diameter	mm	125	125
Weight according to EPTA-Procedure 01/2003	kg	1.3	1.3
Protection class		□/II	□/II

The values given are valid for nominal voltages [U] of 230/240 V. For lower voltage and models for specific countries, these values can vary.

Please observe the article number on the type plate of your machine. The trade names of the individual machines may vary.

## Noise/Vibration Information

Measured values determined according to EN 60745.

Typically the A-weighted noise levels of the product are: Sound pressure level 77 dB(A); Sound power level 88 dB(A). Uncertainty K=2.8 dB.

### Wear hearing protection!

Vibration total values (triax vector sum) determined according to EN 60745:

Vibration emission value  $a_h=5.0 \text{ m/s}^2$ , Uncertainty  $K=1.5 \text{ m/s}^2$ .

**⚠ WARNING** The vibration emission level given in this information sheet has been measured in accordance with a standardised test given in EN 60745 and may be used to compare one tool with another.

The vibration emission level will vary because of the ways in which a power tool can be used and may increase above the level given in this information sheet. This could lead to a significant underestimate of exposure when the tool is used regularly in such a way.

**Note:** To be accurate, an estimation of the level of exposure to vibration experienced during a given period of work should also take into account the times when the tool is switched off and when it is running but not actually doing the job. This may significantly reduce the exposure level over the total working period.

## Declaration of Conformity

We declare under our sole responsibility that the product described under •Technical Data is in conformity with the following standards or standardization documents: EN 60745 according to the provisions of the directives 89/336/EEC, 98/37/EC (until Dec. 28, 2009), 2006/42/EG (from Dec. 29, 2009 on).

Dr. Egbert Schneider  
Senior Vice President  
Engineering

Dr. Eckerhard Strötgen  
Head of Product  
Certification

*Dr. Egbert Schneider* i.v. *Dr. Eckerhard Strötgen*

06.12.2006, Robert Bosch GmbH, Power Tools Division  
D-70745 Leinfelden-Echterdingen

## Assembly

- Before any work on the machine itself, pull the mains plug.

## Replacing the Sanding Sheet (see figure A)

When attaching a new sanding sheet, remove any dust or debris from the sanding plate **4**, e. g., with a brush.

The surface of the sanding plate **4** is fitted with Velcro backing for quick and easy fastening of sanding sheets with Velcro adhesion.

Press the sanding sheet **5** firmly against the bottom side of the sanding plate **4**.

To ensure optimum dust extraction, pay attention that the punched holes in the sanding sheet match with the holes in the sanding plate.

For easy adjustment of the sanding sheet **5** to the sanding plate **4**, use the adjustment aid in the tool case as shown in the following figure. Place the sanding sheet into the adjustment aid with the Velcro facing upward and firmly push on the machine with the sanding plate.

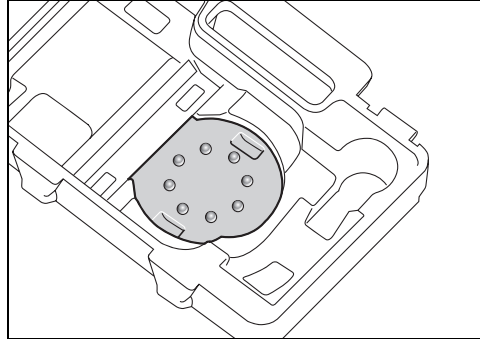

### Selecting the Sanding Sheet

Depending on the material to be worked and the required rate of material removal, different sanding sheets are available:

	Material	Application	Grain size	
<b>White: Paint</b>	<ul style="list-style-type: none"> <li>- Paint</li> <li>- Varnish</li> <li>- Filling compound</li> <li>- Filler</li> </ul>	For sanding off paint	coarse	40 60
		For sanding primer (e. g., for removing brush dashes, drops of paint and paint run)	medium	80 100 120
		For final sanding of primers before coating	fine	180 400
<b>red:Wood<sup>top</sup></b>	<ul style="list-style-type: none"> <li>- All wooden materials (e. g., hardwood, softwood, chipboard, building board)</li> <li>- Metal materials</li> </ul>	For coarse-sanding, e. g. of rough, unplanned beams and boards	coarse	40 60
		For face sanding and planing small irregularities	medium	80 100 120
		For finish and fine sanding of wood	fine	180 240 320 400
<b>black: Stone</b>	<ul style="list-style-type: none"> <li>- Masonry, stone</li> <li>- Marble</li> <li>- Granite</li> <li>- Ceramic</li> <li>- Glass</li> <li>- Plexiglas</li> <li>- Automotive paint</li> <li>- Corian®</li> <li>- Varicor®</li> </ul>	For pre-sanding	coarse	60
		For shaping and braking edges	medium	80 100 120
		For final sanding and forming	fine	180 240 320 400
		For polish-sanding and rounding off edges	very fine	600 1200



## Replacing the Sanding Plate (see figure B)

**Note:** Replace a damaged sanding plate **4** immediately.

Pull off the sanding sheet or the polishing accessory. Unscrew the four screws **6** completely and remove the sanding plate **4**. Attach the new sanding plate **4** and tighten the screws again.

**Note:** When attaching the sanding plate, pay attention that the toothing of the drive element engage into the openings of the sanding plate.

## Dust/Chip Extraction

### Integrated Dust Extraction with Dust Box (see figures C1 C4)

Attach the dust box **3** onto the extraction outlet **7** until it latches.

The filling level of the dust box **3** can easily be checked through the transparent container.

To empty the dust box **3**, pull it off downward with a light twisting motion.

Before opening the dust box **3**, it is recommended to loosen the dust from the filter element by gently striking it against a firm support (as shown in the figure).

Hold the dust box **3** firmly, fold the filter element **8** upward and empty the dust box. Clean the thin plates of the filter element **8** with a soft brush.

### External Dust Extraction (see figure D)

Insert a vacuum hose **9** onto the extraction outlet **7**. Connect the vacuum hose **9** to a vacuum cleaner. See the overview for connecting to various vacuum cleaners at the end of these operating instructions.

The vacuum cleaner must be suitable for the material being worked.

When vacuuming dry dust that is especially detrimental to health or carcinogenic, use a special vacuum cleaner.

## Operation

### Starting Operation

- **Observe correct mains voltage! The voltage of the power source must agree with the voltage specified on the nameplate of the machine. Power tools marked with 230 V can also be operated with 220 V.**

### Switching On and Off

To start the machine, tilt the On/Off switch **1** toward the right to the **•I** position.

To switch off the machine, tilt the On/Off switch **1** toward the left to the **•0** position.

### Preselecting the Speed (GEX 125-1 AE)

The required speed can be preselected with the thumbwheel **2** (also while running).

- 1 – 2 low speed
- 3 – 4 medium speed
- 5 – 6 high speed

The required speed depends on the material and the working conditions and can be determined through practical testing.

After longer periods of working at low speed, allow the machine to cool down by running it for approx. 3 minutes at maximum speed with no load.

### Sanding Plate Brake

An integrated sanding plate brake reduces the speed when running at no load so that scoring is prevented when placing the machine onto the workpiece.

If the no-load speed continuously increases over the course of time, then the sanding plate is damaged and must be replaced or the sanding plate brake is worn. A worn sanding plate brake must be replaced by an authorized after-sales service agent for Bosch power tools.

## Operating Instructions

- **Wait until the machine has come to a standstill before placing it down.**

For fatigue-free working, the machine can be held from above, sideways or from the front, depending on the application. (see figure E)

### Sanding Surfaces

Switch the machine on, place it with the complete sanding surface on the surface to be worked and move the machine with moderate pressure over the workpiece.

The removal capacity and the sanding pattern are mainly determined by the selection of the sanding sheet, the preselected speed range (GEX 125-1 AE) and the applied pressure.

Only flawless sanding sheets achieve good sanding capacity and extend the service life of the machine.

Pay attention to apply uniform sanding pressure; this increases the working life of the sanding sheets.

Intensifying the sanding pressure does not lead to an increase of the sanding capacity, but to increased wear of the machine and the sanding sheet.

A sanding sheet that has been used for metal should not be used for other materials.

Use only original Bosch sanding accessories.



### Rough Sanding

Attach a sanding sheet with coarse grain.

Apply only light pressure to the machine so that it runs at high speed and high material removal is achieved.

### Fine Sanding

Attach a sanding sheet with fine grain.

By lightly varying the application pressure or changing the speed stage (GEX 125-1 AE), the sanding plate speed can be reduced whereby the orbital action is maintained.

With moderate pressure, move the machine in a circular pattern or alternately in lengthwise and crosswise directions over the workpiece. Do not tilt the machine to avoid sanding through the workpiece (e. g. when sanding veneer).

After finishing the working procedure, switch the power tool off.

### Polishing (GEX 125-1 AE)

For the polishing of weathered paint or buffing out scratches (e. g., acrylic glass), the machine can be equipped with appropriate polishing accessories such as lamb's wool bonnet, polishing felt or sponge (accessories).

Select a low speed for polishing (stage 1 – 2) in order to avoid excessive heating of the surface.

Apply polishing agent crosswise or in a circular motion with a polishing sponge and moderate pressure, and then allow it to dry lightly.

Polish the partially dried polishing agent with crosswise or circular motions using a lamb's wool polishing bonnet.

Clean the polishing accessories regularly to ensure good polishing results. Wash out polishing accessories with a mild detergent and warm water; do not use paint thinner.

## Maintenance and Service

### Maintenance and Cleaning

- ▶ **Before any work on the machine itself, pull the mains plug.**
- ▶ **For safe and proper working, always keep the machine and ventilation slots clean.**

If the machine should fail despite the care taken in manufacturing and testing procedures, repair should be carried out by an after-sales service centre for Bosch power tools.

In all correspondence and spare parts order, please always include the 10-digit article number given on the type plate of the machine.

### WARNING! Important instructions for connecting a new 3-pin plug to the 2-wire cable.

The wires in the cable are coloured according to the following code:

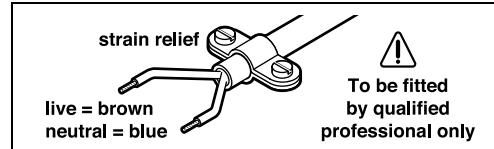

Do **not** connect the blue or brown wire to the earth terminal of the plug.

**Important:** If for any reason the moulded plug is removed from the cable of this power tool, it must be disposed of safely.

### Guarantee

We guarantee Bosch appliances in accordance with statutory/country-specific regulations (proof of purchase by invoice or delivery note). Damage attributable to normal wear and tear, overload or improper handling will be excluded from the guarantee.

In case of complaint please send the machine, **undismantled**, to your dealer or the Bosch Service Center for Electric Power Tools.

### Warning!

Freight and insurance costs are charged to the client, even for warranty claims.

### Service and Customer Assistance

Exploded views and information on spare parts can be found under:

[www.bosch-pt.com](http://www.bosch-pt.com)

### Disposal

The machine, accessories and packaging should be sorted for environmental-friendly recycling.

### Only for EC countries:



Do not dispose of power tools into household waste!

According the European Guideline 2002/96/EC for Waste Electrical and Electronic Equipment and its implementation into national right, power tools that are no longer usable must be collected separately and disposed of in an environmentally correct manner.

**Subject to change without notice.**

