

**Robert Bosch GmbH**

Power Tools Division  
 Max-Lang-Strasse 40 - 46  
 70771 Leinfelden-Echterdingen  
 Germany  
[www.bosch-pt.com](http://www.bosch-pt.com)

1 619 929 L62 (2013.02) PS / 247 UNI



1 619 929 L62

## GAS 55 M AFC Professional



<b>de</b> Originalbetriebsanleitung	<b>tr</b> Orijinal işletme talimatı	<b>hr</b> Originalne upute za rad
<b>en</b> Original instructions	<b>pl</b> Instrukcja oryginalna	<b>et</b> Algupärane kasutusjuhend
<b>fr</b> Notice originale	<b>cs</b> Původní návod k používání	<b>lv</b> Instrukcijas oriģinālvalodā
<b>es</b> Manual original	<b>sk</b> Pôvodný návod na použitie	<b>lt</b> Originali instrukcija
<b>pt</b> Manual original	<b>hu</b> Eredeti használati utasítás	<b>ar</b> تعليمات التشغيل الأصلية
<b>it</b> Istruzioni originali	<b>ru</b> Оригинальное руководство по эксплуатации	<b>fa</b> دفترچه راهنمای اصلی
<b>nl</b> Oorspronkelijke gebruiksaanwijzing	<b>uk</b> Оригінальна інструкція з експлуатації	
<b>da</b> Original brugsanvisning	<b>ro</b> Instrucțiuni originale	
<b>sv</b> Bruksanvisning i original	<b>bg</b> Оригинална инструкция	
<b>no</b> Original driftsinstruks	<b>sr</b> Originalno uputstvo za rad	
<b>fi</b> Alkuperäiset ohjeet	<b>sl</b> Izvirna navodila	
<b>el</b> Πρωτότυπο οδηγιών χρήσης		



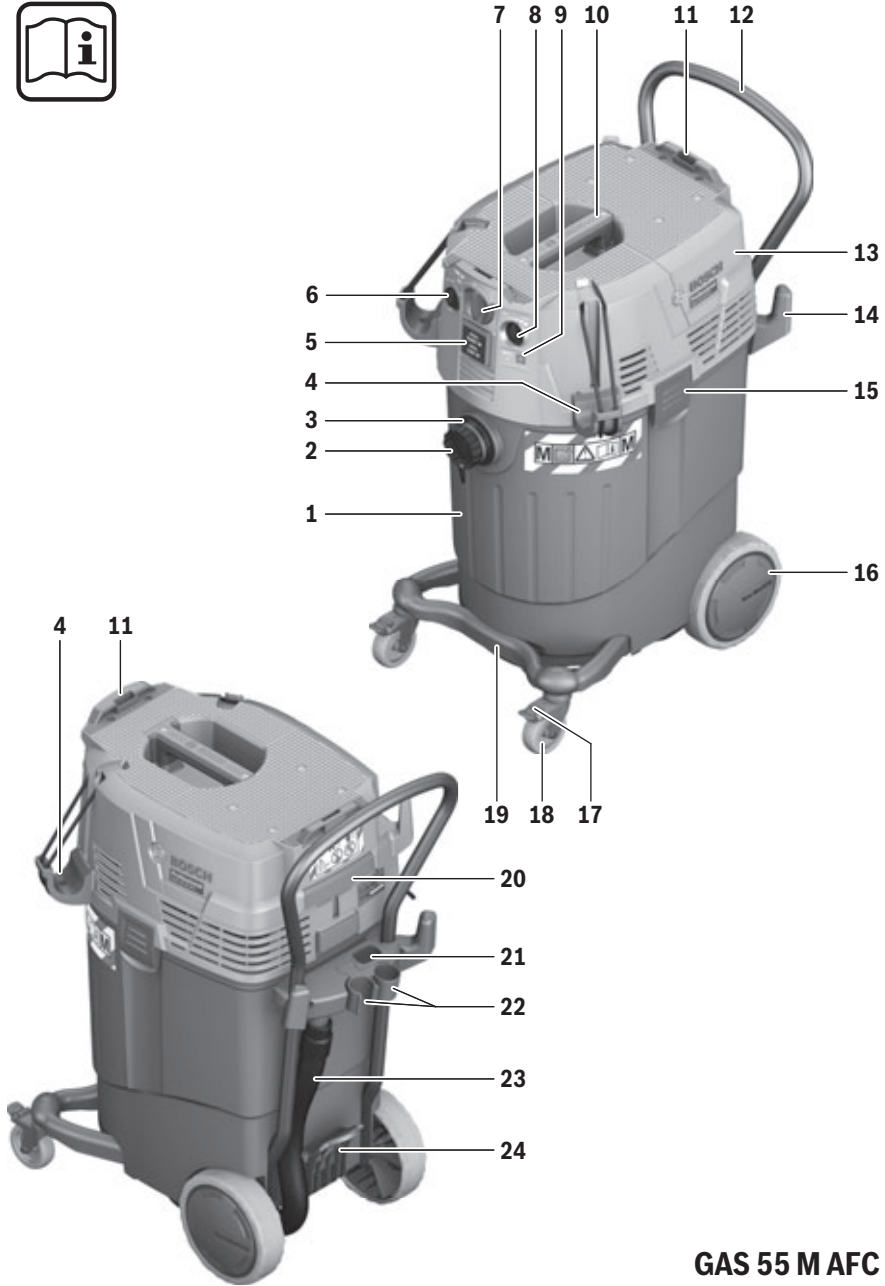

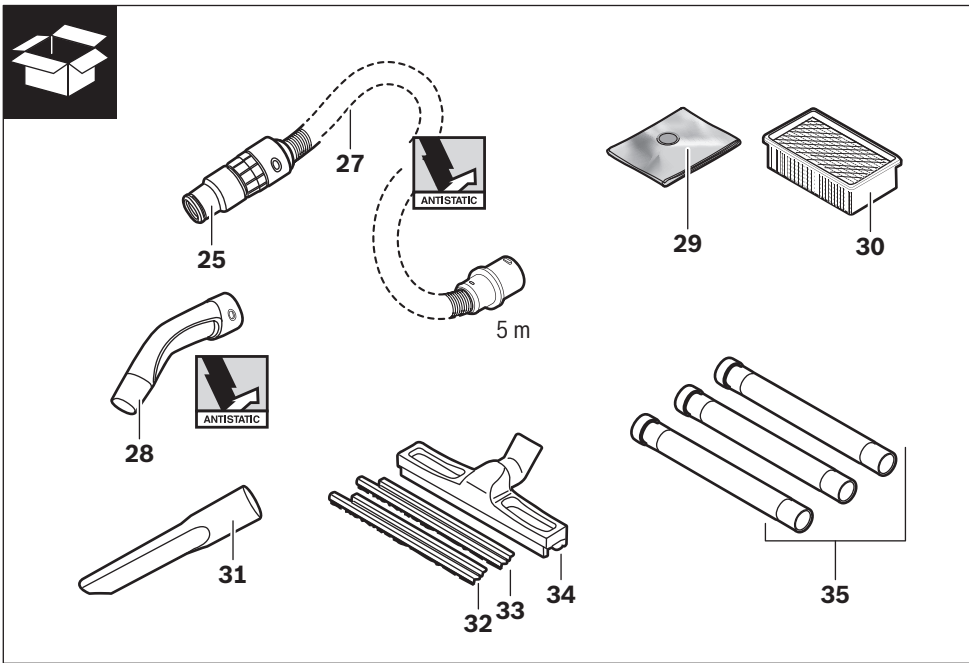
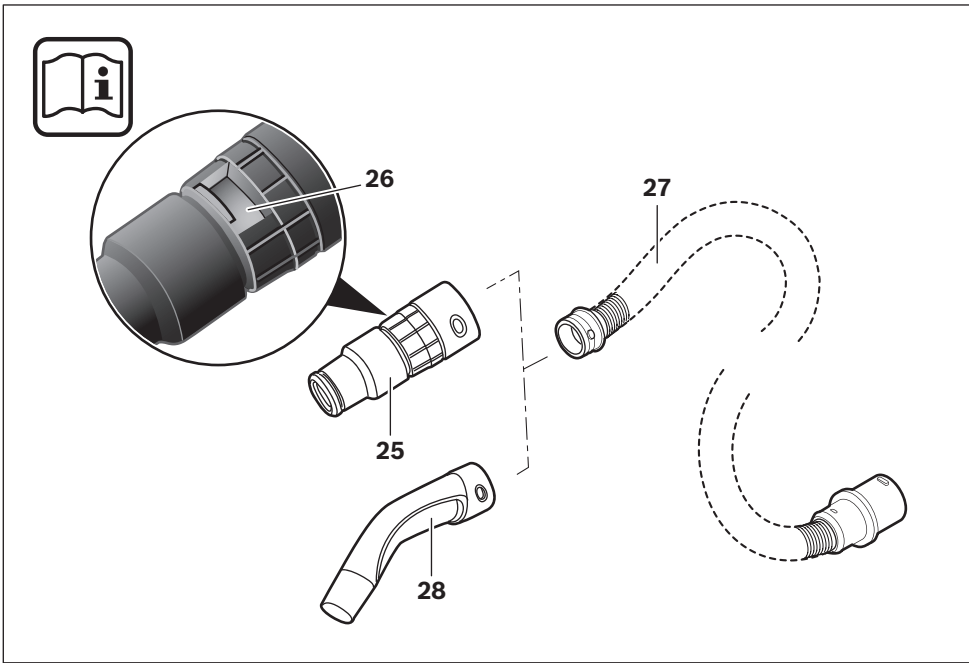

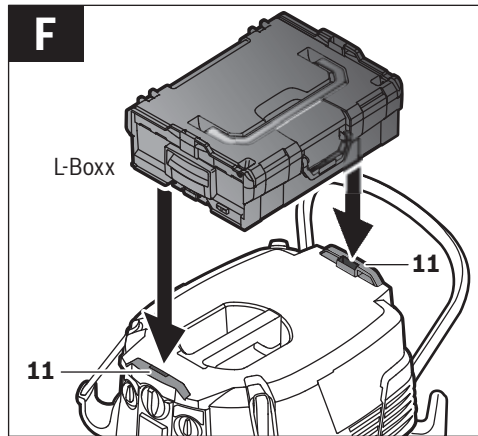
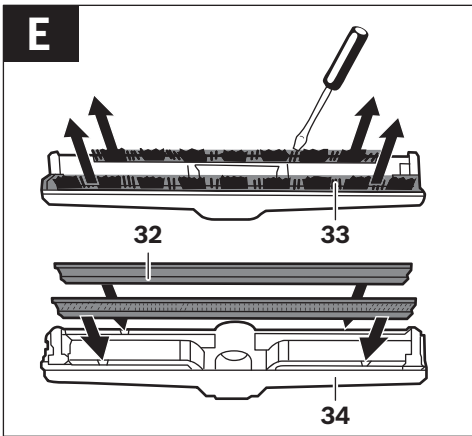
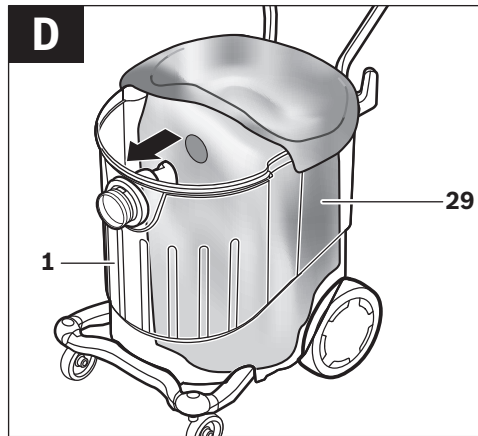
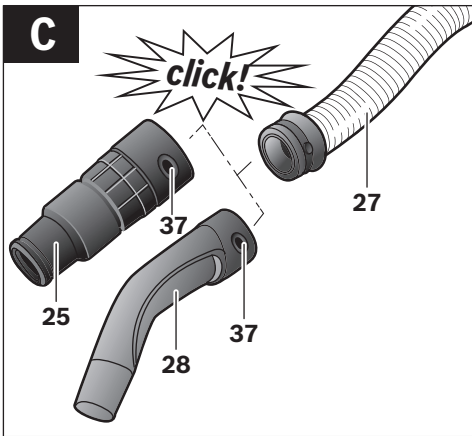
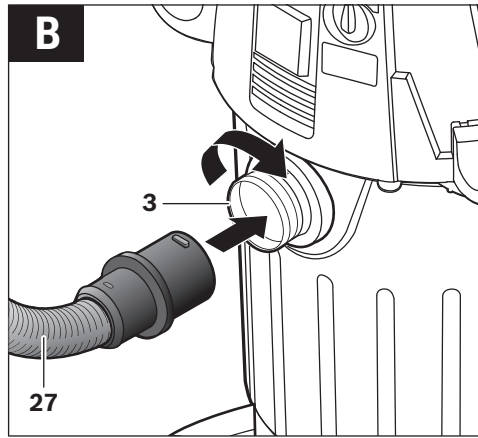
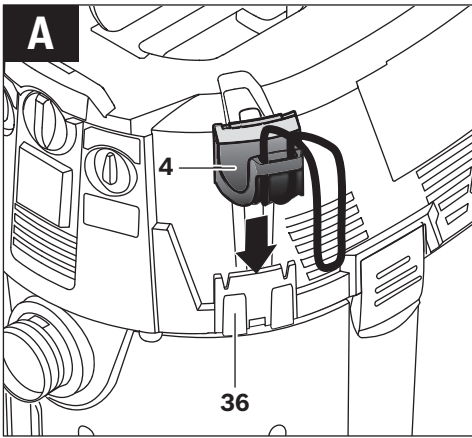

6 |

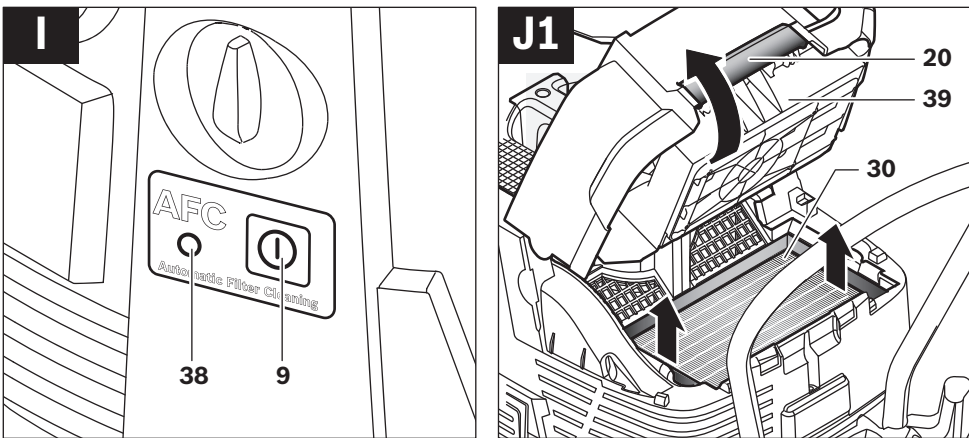
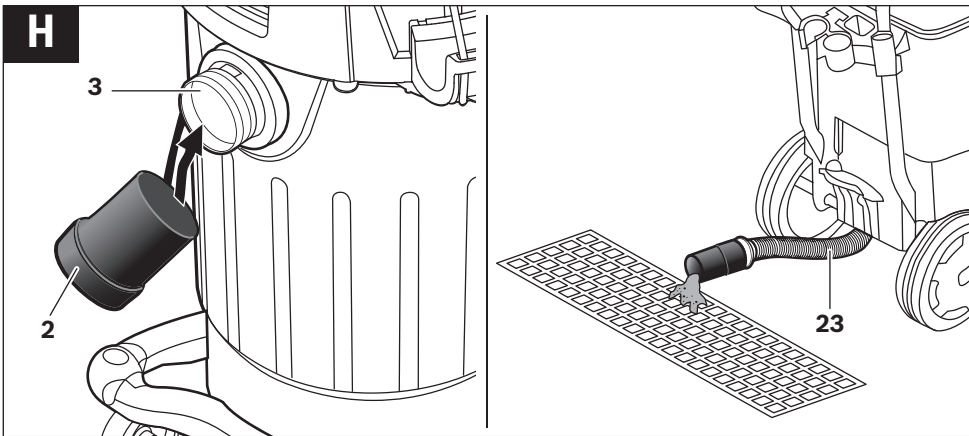
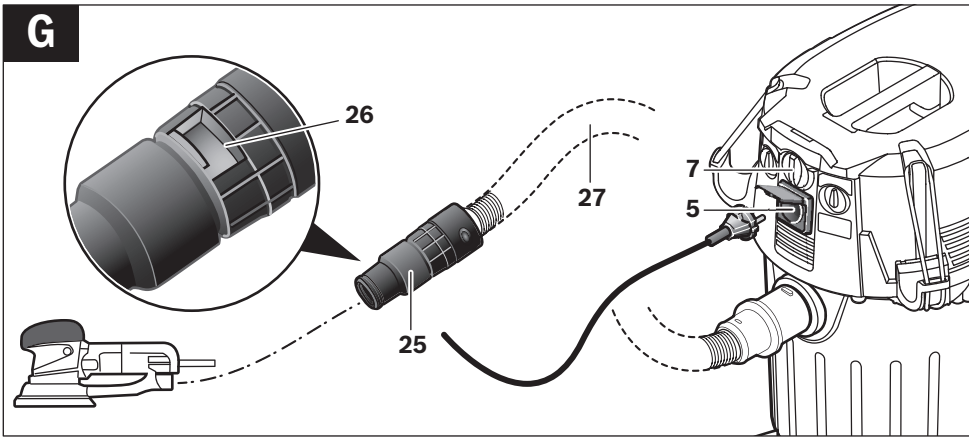

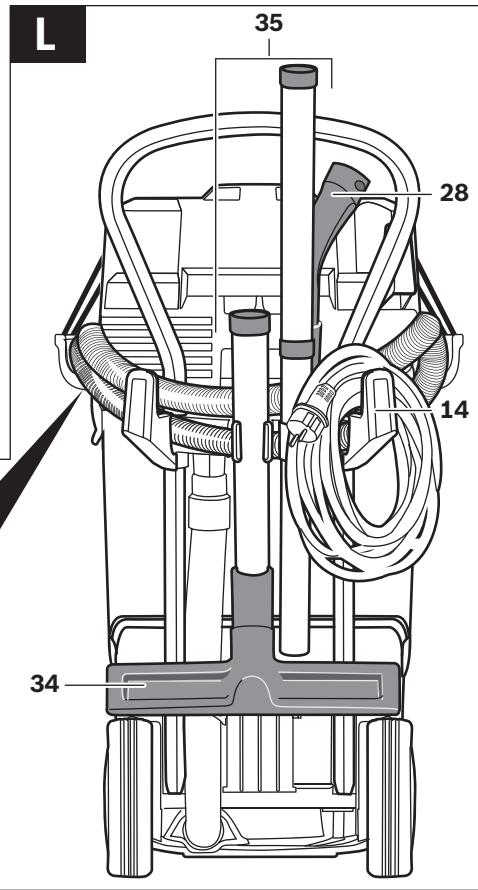
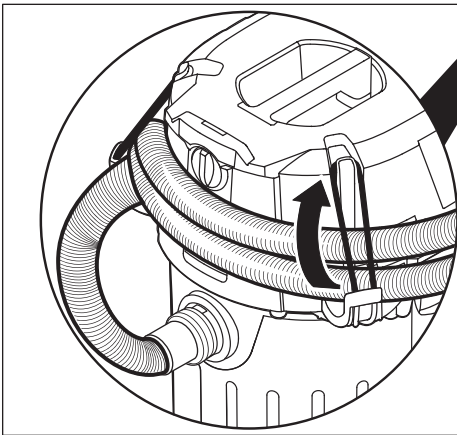
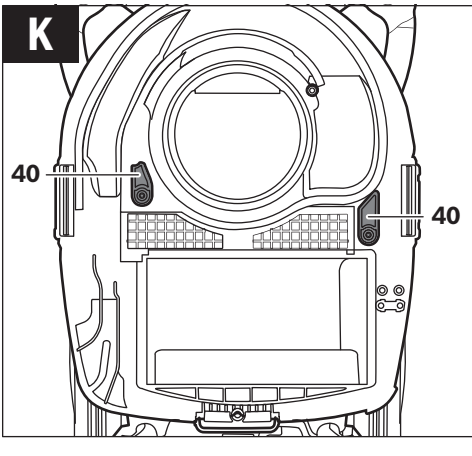
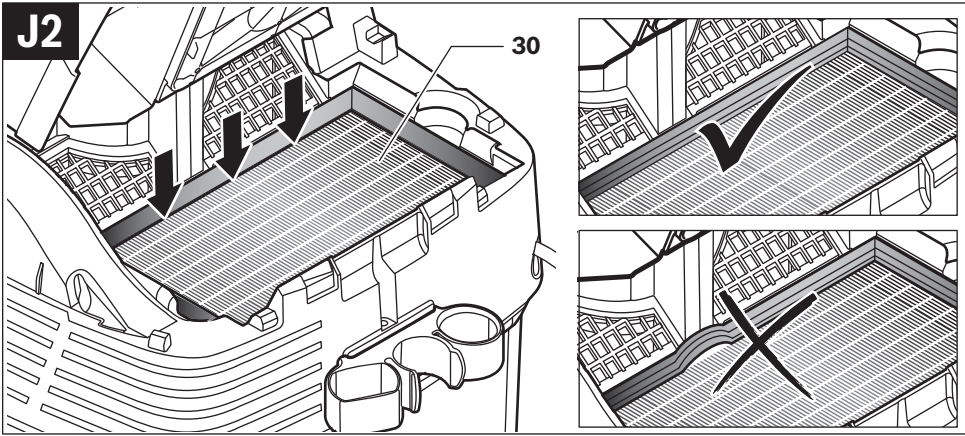

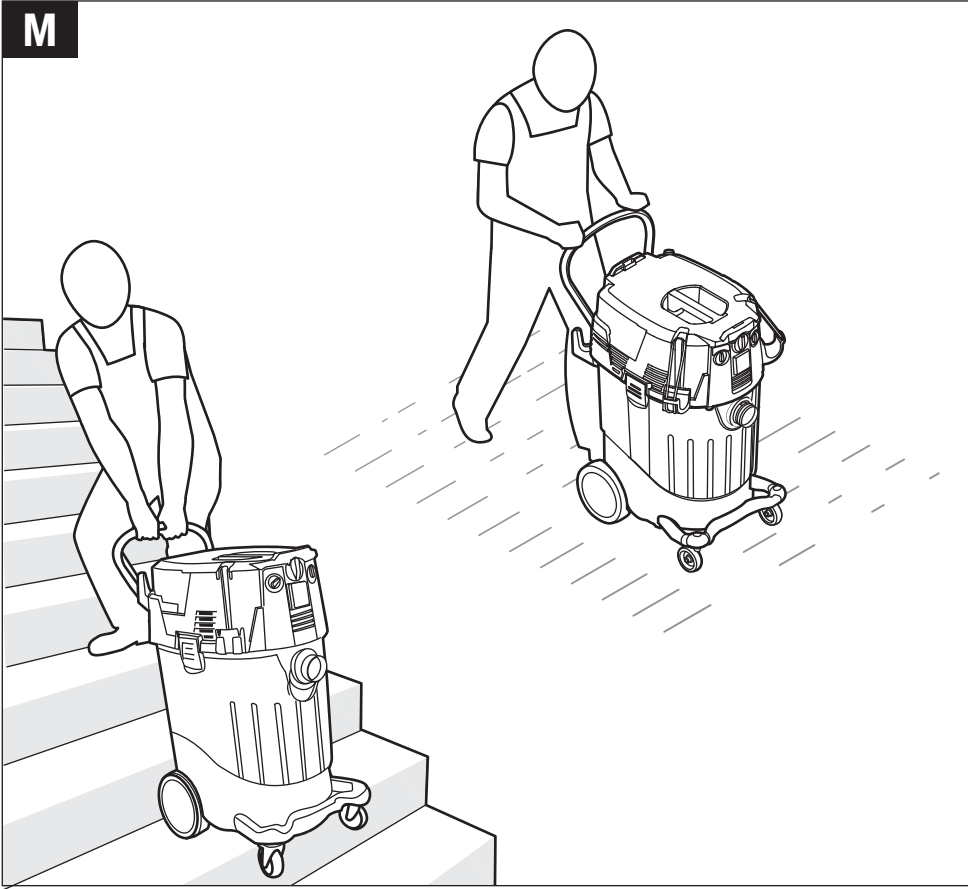

## Kundendienst und Anwendungsberatung

Geben Sie bei allen Rückfragen und Ersatzteilbestellungen bitte unbedingt die 10-stellige Sachnummer laut Typenschild des Saugers an.

Der Kundendienst beantwortet Ihre Fragen zu Reparatur und Wartung Ihres Produkts sowie zu Ersatzteilen. Explosionszeichnungen und Informationen zu Ersatzteilen finden Sie auch unter:

**www.bosch-pt.com**

Das Bosch-Anwendungsberatungs-Team hilft Ihnen gerne bei Fragen zu unseren Produkten und deren Zubehör.

**www.powertool-portal.de**, das Internetportal für Handwerker und Heimwerker.

### Deutschland

Robert Bosch GmbH  
Servicezentrum Elektrowerkzeuge  
Sur Luhne 2

375 9 Alefeld – Willershausen

Unter [www.bosch-pt.com](http://www.bosch-pt.com) können Sie online Ersatzteile bestellen oder Reparaturen anmelden.

Kundendienst: Tel.: (0711) 400404 0

Fax: (0711) 400404 1

E-Mail: [Servicezentrum.Elektrowerkzeuge@de.bosch.com](mailto:Servicezentrum.Elektrowerkzeuge@de.bosch.com)

Anwendungsberatung: Tel.: (0711) 400404 0

Fax: (0711) 400404 2

E-Mail: [Anwendungsberatung.pt@de.bosch.com](mailto:Anwendungsberatung.pt@de.bosch.com)

### Österreich

Tel.: (01) 797222010

Fax: (01) 797222011

E-Mail: [service.elektrowerkzeuge@at.bosch.com](mailto:service.elektrowerkzeuge@at.bosch.com)

### Schweiz

Tel.: (044) 471511

Fax: (044) 471551

E-Mail: [AfterSales.Service@de.bosch.com](mailto:AfterSales.Service@de.bosch.com)

### Luxemburg

Tel.: 332 25 05 9

Fax: 332 25 0595

E-Mail: [outillage.gereedschap@be.bosch.com](mailto:outillage.gereedschap@be.bosch.com)

## Entsorgung

Sauger, Zubehör und Verpackungen sollen einer umweltgerechten Wiederverwertung zugeführt werden.

Werfen Sie den Sauger nicht in den Hausmüll

### Nur für EU-Länder:



Gemäß der Europäischen Richtlinie 2012/19/EU über Elektro- und Elektronik-Altgeräte und ihrer Umsetzung in nationales Recht müssen nicht mehr gebrauchsfähige Elektrowerkzeuge getrennt gesammelt und einer umweltgerechten Wiederverwertung zugeführt werden.

Änderungen vorbehalten.

## English

### Safety Notes



**Read all safety warnings and all instructions.** Failure to follow the warnings and instructions may result in electric shock, fire and/or serious injury.

**Save these instructions.**

- ▶ **Never vacuum materials that contain asbestos.** Asbestos is considered carcinogenic.

**WARNING** Use the vacuum cleaner only after having received sufficient information on the usage of the vacuum cleaner, the materials to be vacuumed and their safe disposal. A thorough introduction reduces operating errors and injuries.

- ▶ **This vacuum cleaner is not intended for use by children and persons with reduced physical, sensory or mental capabilities, or lack of experience and knowledge.** Otherwise, there is danger of operating errors and injuries.

- ▶ **Supervise children.** This will ensure that children do not play with the vacuum cleaner.

- ▶ **Cleaning and user maintenance of the vacuum cleaner shall not be made by children without supervision.**

**WARNING** The vacuum cleaner is suitable for vacuuming dry materials and, by taking suitable measures, also for vacuuming liquids. The penetration of liquids increases the risk of an electric shock.

- ▶ **Do not vacuum inflammable or explosive fluids; for example, benzene, oil, alcohol, solvents. Do not vacuum hot or burning dust. Do not operate the machine in rooms where the danger of an explosion exists.** The dusts, vapours or fluids can ignite or explode.

**WARNING** Use the socket only for the purposes specified in of the operating instructions.

**WARNING** Switch the vacuum cleaner off immediately as soon as foam or water comes out, and empty the container. Otherwise, the vacuum cleaner can become damaged.

**IMPORTANT** Keep the vacuum cleaner away from rain or moisture. The penetration of water into the vacuum cleaner lid increases the risk of an electric shock.

- ▶ **The vacuum cleaner may only be stored indoors.**

**IMPORTANT** Clean the filling-level sensors for liquids at regular intervals, and check them for damage. Otherwise, their function can be impaired.

- ▶ **When operating the vacuum cleaner in damp environments, use a residual current device (RCD).** Using a residual current device (RCD) reduces the risk of an electric shock.

- ▶ **Connect the vacuum cleaner to a properly earthed mains supply.** The socket outlet and the extension cable must have an operative protective conductor.



## 18 | English

- ▶ **Before each use, check the vacuum cleaner, cable and plug. Do not use the vacuum cleaner when defects are detected. Do not open the vacuum cleaner yourself and have it repaired only by qualified personnel using original spare parts.** Damaged vacuum cleaner, cables and plugs increase the risk of an electric shock.
- ▶ **Do not drive over, crush or stretch the cable. Do not pull the cable to unplug the plug from the socket outlet or to move the vacuum cleaner.** Damaged cables increase the risk of an electric shock.
- ▶ **Before maintaining or cleaning the vacuum cleaner, making any adjustments, changing accessories or placing the vacuum cleaner aside, remove the plug from the socket outlet.** This safety measure prevents accidental starting of the vacuum cleaner.
- ▶ **Provide for good ventilation at the working place.**
- ▶ **Have the vacuum cleaner repaired only through qualified specialists and only using original spare parts.** This ensures that the safety of your vacuum cleaner is maintained.

**⚠ WARNING** The vacuum cleaner contains materials that are hazardous to one's health.

Have the emptying and maintenance, incl. the disposal of dust-collection containers, carried out only by specialists. Appropriate protective equipment is required. Do not operate the vacuum cleaner without the complete filter system. Otherwise there is danger to your own health.

- ▶ **Before restarting, check the proper condition of the vacuum hose. When doing this, leave the vacuum hose mounted to the vacuum cleaner to avoid dust from coming out.** Otherwise, you could possibly inhale dust.
- ▶ **Use the mains cable and the vacuum hose carefully.** Other persons could be harmed.
- ▶ **Do not clean the vacuum cleaner with a water jet pointed directly at it.** The penetration of water into the vacuum cleaner lid increases the risk of an electric shock.

**Products sold in GB only:** Your product is fitted with an BS 1363/A approved electric plug with internal fuse (ASTA approved to BS 1362).

If the plug is not suitable for your socket outlets, it should be cut off and an appropriate plug fitted in its place by an authorised customer service agent. The replacement plug should have the same fuse rating as the original plug.

The severed plug must be disposed of to avoid a possible shock hazard and should never be inserted into a mains socket elsewhere.

**Products sold in AUS and NZ only:** Use a residual current device (RCD) with a rated residual current of 30 mA or less.

## Symbols

The following symbols could have a meaning for the use of your vacuum cleaner. Please take note of the symbols and their meaning. The correct interpretation of the symbols will help you to use the vacuum cleaner in a better and safer manner.

### Symbols and their meaning



**⚠ CAUTION** Read all safety warnings and all instructions. Failure to follow the warnings and instructions may result in electric shock, fire and/or serious injury.



Vacuum cleaners of dust category M according to IEC/EN 60335-2-69 for **dry vacuuming** of materials with an exposition limit value  $\geq 0.1 \text{ mg/m}^3$  that are hazardous to one's health



**⚠ WARNING** The vacuum cleaner contains materials that are hazardous to one's health. Have the emptying and maintenance, incl. the disposal of dust-collection containers, carried out only by specialists. Appropriate protective equipment is required. Do not operate the vacuum cleaner without the complete filter system. Otherwise there is danger to your own health.

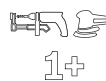

**Automatic Start/Stop feature**  
Extraction of dusts resulting from running power tools  
The vacuum cleaner automatically switches on and off with a time delay

0



### Switching Off

**Vacuuming**  
Vacuuming of deposited dusts

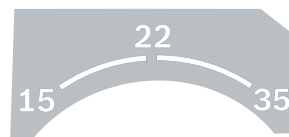

- 15** Airflow monitoring for a 15 mm hose diameter
- 22** Airflow monitoring for a 22 mm hose diameter
- 35** Airflow monitoring for a 35 mm hose diameter

## Symbols and their meaning



- Min/Max** Infinitely variable control of the vacuuming power:
- Maximum vacuum capacity for applications with intense dust development
  - Reduced vacuum capacity for applications with low dust development and for control of the vacuuming power between connected power tool and workpiece surface (e. g. when sanding)

**max.  
2200 W  
min.  
100 W**

Specification of the allowable load of the connected power tool (country-specific)



- AFC** Automatic filter cleaning  
(AFC = Automatic Filter Cleaning)



For transport of the vacuum cleaner and for place-saving storage of VAC accessories and/or power tools, an L-Boxx can be mounted on the vacuum cleaner lid.



- ▶ **Do not vacuum with an L-Boxx mounted.** The centre of gravity of the vacuum cleaner shifts upward. The vacuum cleaner can tip over. Danger of injury and causing damage.



**max. 1 L-Boxx  
max. 15 kg**

Attach only one L-Boxx (max.).  
The weight of the L-Boxx with contents must not exceed 15 kg.

## Symbols and their meaning



- ▶ **Do not hang the vacuum cleaner, e. g. for transport purposes, to a crane hook.** The vacuum cleaner is not suitable for handling by crane. Danger of injury and causing damage.



- ▶ **Do not use the vacuum cleaner as a seat, ladder or stepladder.** The vacuum cleaner can tip over and become damaged. Danger of injury.

## Product Description and Specifications

While reading the operating instructions, unfold the graphics page for the vacuum cleaner and leave it open.

## Intended Use

The machine is intended for collection, vacuuming, conveying and separation of wood chips, as well as non-flammable dry dusts, non-flammable liquids and water-air mixtures. The vacuum cleaner is dust-technically checked and corresponds with dust category M. It is suitable for the increased demands of industrial usage, as required in trades, industry and workshops.

According to IEC/EN 60335-2-69, vacuum cleaners of dust category M may only be used for vacuuming and extraction of hazardous materials with an exposition limit value  $\geq 0.1 \text{ mg/m}^3$ .

Use the vacuum cleaner only when you fully understand and can perform all functions without limitation, or have received appropriate instructions.

## Product Features

The numbering of the product features refers to the illustration of the vacuum cleaner on the graphics page.

- 1 Container
- 2 Plug cap for the vacuum hose connection
- 3 Hose connection piece
- 4 Vacuum-hose holder
- 5 Socket for power tool
- 6 Airflow regulator
- 7 Mode selector switch
- 8 Control knob for vacuum capacity
- 9 AFC button
- 10 Carrying handle
- 11 L-Boxx retainer
- 12 Push handle
- 13 Vacuum lid
- 14 Cable holder
- 15 Latch of the vacuum cover
- 16 Rear wheel
- 17 Castor brake
- 18 Castor

## 20 | English

- 19 Castor frame
- 20 Locking latch of filter cover
- 21 Holder for crevice nozzle/elbow
- 22 Holder for vacuum tubes
- 23 Drain hose
- 24 Holder for floor nozzle
- 25 Tool sleeve
- 26 Air diffuser
- 27 Vacuum hose
- 28 Elbow
- 29 Disposal bag
- 30 Flat-fold filter (PES)
- 31 Crevice nozzle
- 32 Rubber lip
- 33 Brush insert
- 34 Floor nozzle
- 35 Vacuum tube
- 36 Retainer for vacuum-hose holder
- 37 Snap-fastener
- 38 Signalling LED
- 39 Filter cover
- 40 Level sensors

Accessories shown or described are not part of the standard delivery scope of the product. A complete overview of accessories can be found in our accessories program.

### Technical Data

Wet/dry vacuum cleaner		GAS 55 M AFC
Article number		3 601 C3 3..
Rated power input	W	1200
Frequency	Hz	50/60
Container volume (gross)	l	55
Net volume (for fluids)	l	40
Dust bag contents	l	27
Max. vacuum		
– Vacuum cleaner	hPa	230
– Turbine	hPa	254
Max. flow rate		
– Vacuum cleaner	l/s	36
– Turbine	l/s	74
Max. vacuum capacity	W	13 0
Surface of flat-fold filter	m <sup>2</sup>	0.615
Dust category		M
Weight according to EPTA-Procedure 01/2003	kg	16.2
Protection class		⊕/I
Degree of protection		IP 4
Measured with a Ø 35 mm and 5 m long vacuum hose		
The values given are valid for nominal voltages U of 230 V. For lower voltage and models for specific countries, these values can vary.		

### Automatic Start/Stop feature\*

	Rated voltage	max. power output	min. power output
EU	220 – 240 V	2200 W	100 W
U	110 V	750 W	100 W
U /D	240/230 V	1 00 W	100 W
CH	230 V	1100 W	100 W

\*Specification of the allowable load of the connected power tool (country-specific)

### Noise Information

Measured sound values determined according to EN 60704. Typically the A-weighted sound pressure level of the vacuum cleaner is lower than 70 dB(A). Uncertainty = 3 dB. The noise level when working can exceed 0 dB(A).

### Wear hearing protection!

### Declaration of Conformity

We declare under our sole responsibility that the product described under 'Technical data' is in conformity with the following standards or standardization documents: EN 60335 and the directives 2011/65/EU, 2006/42/EC, 2004/10 /EC including their amendments.

Technical file (2006/42/EC) at:  
Robert Bosch GmbH, PT/ETM9,  
D-70745 Leinfelden-Echterdingen

Dr. Egbert Schneider  
Senior Vice President  
Engineering

Helmut Heinzelmann  
Head of Product Certification  
PT/ETM9

*Dr. Egbert Schneider* i.V. *Helmut Heinzelmann*

Robert Bosch GmbH, Power Tools Division  
D-70745 Leinfelden-Echterdingen  
15.02.2013

### Assembly

- ▶ Before any work on the vacuum cleaner itself, pull the mains plug.

#### Mounting the Vacuum-hose Holder (see figure A)

- Slide the vacuum-hose holders **4** firmly from above into the retainers **36** intended for this purpose, until they engage.

#### Mounting the Vacuum Hose (see figure B)

- Mount the vacuum hose **27** onto the hose connection piece **3** and turn it in clockwise direction to the stop.

**Note:** While vacuuming, an electrostatic charge develops in the vacuum hose and accessories caused through the friction of the dust, which the operator could experience in the form of static discharging (dependent on environmental influences and physical perception).

As a general rule, Bosch recommends using an anti-static vacuum hose (accessory), when vacuuming fine dusts and dry materials.

## Mounting VAC Accessories (see figure C)

The vacuum hose **27** is equipped with a clip system, with which the VAC accessories (tool sleeve **25**, elbow **28**) can be connected.

### Mounting the Tool Sleeve

- Mount the tool sleeve **25** onto the vacuum hose **27** until both snap-fasteners **37** of the vacuum hose can be heard to engage.
- To disassemble, press both snap-fasteners **37** inward and pull the components apart.

### Mounting Nozzles and Tubes

- Mount the elbow **28** onto the vacuum hose **27** until both snap-fasteners **37** of the vacuum hose can be heard to engage.
- Afterwards, mount the desired VAC accessory (floor nozzle, crevice nozzle, vacuum tube, etc.) firmly onto the elbow **28**.
- To disassemble, press both snap-fasteners **37** inward and pull the components apart.

## Inserting/Removing a Disposal Bag or Dust Bag (Dry Vacuuming) (see figure D)

For dry vacuuming of materials according to dust category M, a disposal bag **29** or a dust bag **must** be inserted.

When vacuuming materials with or without an exposition limit value  $\geq 1 \text{ mg/m}^3$  (according to dust category L), it is possible to vacuum directly into the container.

**Note:** When using a paper filter bag, the automatic filter cleaning (AFC) (see 'Deactivating the AFC', page 23) **must**, and when using a fleece filter bag, **should** be shut off.

Do not fill the disposal bag **29** with more than **25 kg (max.)**.

**⚠ WARNING** The vacuum cleaner contains materials that are hazardous to one's health.

**Have the emptying and maintenance, incl. the disposal of dust-collection containers, carried out only by specialists. Appropriate protective equipment is required. Do not operate the vacuum cleaner without the complete filter system.** Otherwise there is danger to your own health.

### Inserting a Disposal bBag

- Unlock the latches **15** and remove the vacuum lid **13**.
- Insert the disposal bag **29** into the container **1** with the filling opening toward the front.
- Pull the filling opening over the connection flange into the recess of the connection flange.
- Make sure that the disposal bag **29** faces completely against the interior sides of the container **1**.
- Fold the rest of the disposal bag **29** over the edge of the container **1**.
- Reattach the vacuum lid **13** again and lock the latches **15**.

### Removing and Closing the Disposal Bag

- Unlock the latches **15** and remove the vacuum lid **13**.
- Pull the full disposal bag **29** toward the rear off of the connection flange.
- Carefully remove the disposal bag **29** out of the vacuum cleaner without damaging it.  
When doing this, pay attention that the disposal bag does

not get caught or ripped open against the connection flange or other sharp objects.

- Pull the cover off of the adhesive strip, close the disposal bag and tape it shut.  
Afterwards, tie off the disposal bag **29** below the filling opening with the pulled off cover of the adhesive strip.

### Replacing/Inserting the Dust Bag (Accessory)

- Unlock the latches **15** and remove the vacuum lid **13**.
- Pull off the full dust bag from the connection flange toward the rear. Close the opening of the dust bag by folding down the lid. Remove the closed dust bag from the vacuum cleaner.
- Work the new dust bag over the connection flange of the vacuum cleaner. Make sure that the dust bag faces completely against the interior sides of the container **1** over its full length.
- Reattach the vacuum lid **13** again and lock the latches **15**.

## Inserting the Rubber Lip (Wet Vacuuming) (see figure E)

**Note:** The requirements for the ingress degree (dust category M) have only been proven for dry vacuuming.

- Carefully pry the brush inserts **33** out of the floor nozzle **34** using a suitable tool.
- Insert the rubber lips **32** into the floor nozzle **34**.

**Note:** The structured side of the rubber lips must face outward.

## Attaching an L-Boxx (see figure F)

For transport of the vacuum cleaner and for place-saving storage of VAC accessories and/or power tools, an L-Boxx can be mounted on the vacuum cleaner lid.

- Mount the L-Boxx onto the retainers **11**.
- ▶ **Do not vacuum with an L-Boxx mounted.** The centre of gravity of the vacuum cleaner shifts upward. The vacuum cleaner can tip over. Danger of injury and causing damage.
- ▶ **Do not carry the vacuum cleaner by the carrying handle of the mounted L-Boxx.** The vacuum cleaner is too heavy for the carrying handle of the L-Boxx. Danger of injury and causing damage.

## Operation

### Starting Operation

- ▶ **Observe correct mains voltage! The voltage of the power source must agree with the voltage specified on the nameplate of the vacuum cleaner. Equipment marked with 230 V can also be operated with 220 V.**
- ▶ **Please inform yourself about the valid regulations/laws for your country concerning the handling of materials that are hazardous to one's health.**

The vacuum cleaner is suitable for vacuuming and extracting the following materials:

- Dusts with an exposition limit value  $\geq 0.1 \text{ mg/m}^3$

The vacuum cleaner may generally not be used in rooms where the danger of an explosion exists.



## 22 | English

To save energy, only switch the vacuum cleaner on when using it.

To ensure optimal vacuuming performance, always completely unwind the vacuum hose **27** from the vacuum cleaner lid **13**.

## Dry Vacuuming

### Vacuuming of deposited dusts

- Set the airflow regulator **6** to the hose diameter being used.
- To switch the vacuum cleaner **on**, set the mode selector switch **7** to the 'vacuuming' symbol.  **1**
- To switch the vacuum cleaner **off**, set the mode selector switch **7** to the 'Off' symbol.  **0**

The vacuum cleaner is equipped with an airflow monitoring system. In the 'vacuuming' operating mode, the airflow is continuously set to a value of 20 m/s, independent of the position of the airflow regulator **6**.

If this value is fallen below, e. g. caused through debris accumulated in the vacuum hose, a full dust bag or a clogged flat-fold filter, an alarm sounds. In this case, shut the vacuum cleaner off and check it as described under 'Correction of Malfunctions'.

### Extraction of dusts resulting from running power tools (see figure G)

- ▶ **An adequate ventilation rate (L) must be provided for when the outgoing air is circulated. Observe the respective national regulations.**

A socket outlet with earthing contact **5** is integrated in the vacuum cleaner. An external power tool can be connected there. Observe the maximal allowable load of the connected power tool.

To ensure sufficient dust transport at the vacuum location, the minimum airflow for the power tool connected must not be fallen below.

Hose Diameter	Airflow Setting Value
35 mm	57.9 m <sup>3</sup> /h
22 mm	41.2 m <sup>3</sup> /h
15 mm	12.7 m <sup>3</sup> /h

- Set the airflow regulator **6** to the hose diameter being used.
- Mount the tool sleeve **25** (see 'Mounting the Tool Sleeve', page 21).
- Insert the tool sleeve **25** into the vacuum connection of the power tool.
- To start the vacuum cleaner's **automatic Start/Stop feature**, set the mode selector switch **7** to the 'Automatic Start/Stop' symbol.  **1+**

In this operating mode, the airflow is electronically monitored according to the setting of the airflow regulator **6**. Sufficient dust transport is ensured when the setting is correctly selected.

- To **start the operation** of the vac, switch on the power tool connected to the socket **5**. The vacuum cleaner starts automatically.
- Switch the power tool off to **end the vacuuming**. The after-run function of the automatic Start/Stop feature lasts approx. 15 seconds, so that residual dust is drawn out of the vacuum hose.
- To switch the vacuum cleaner **off**, set the mode selector switch **7** to the 'Off' symbol.  **0**

When the alarm sounds, the vacuum cleaner must be checked as described under 'Correction of Malfunctions'.

### Wet Vacuuming (see figure H)

- ▶ **Do not vacuum inflammable or explosive fluids; for example, benzene, oil, alcohol, solvents. Do not vacuum hot or burning dust. Do not operate the machine in rooms where the danger of an explosion exists.** The dusts, vapours or fluids can ignite or explode.
- ▶ **The vacuum cleaner may not be used as a water pump.** The vacuum cleaner is intended for vacuuming air and water mixtures.
- ▶ **Before any work on the vacuum cleaner itself, pull the mains plug.**

**Note:** The requirements for the ingress degree (dust category M) have only been proven for dry vacuuming.

- Remove the disposal bag **29** or the dust bag and empty the container **1** before wet vacuuming.

**Note:** For easier disposal when vacuuming liquid-solid mixtures, use a wet filter bag (accessory), which separates liquids from solids.

- Mount the rubber lips into the floor nozzle (see 'Inserting the Rubber Lip', page 21).
- Switch the automatic filter cleaning (AFC) off (see 'Deactivating the AFC', page 23).

The vacuum cleaner is equipped with filling-level sensors **40**. When the maximum filling height is reached, the vacuum cleaner switches off. Set the mode selector switch **7** to the 'off' symbol.

**Note:** When vacuuming non-conductive liquids (e. g. drilling emulsion, oil and grease), the vacuum cleaner is not switched off when the container is full. The level must be monitored continuously and the container emptied in time.

When the alarm sounds while wet vacuuming, the operational safety of the VAC is not impaired. No measures are required to correct the malfunction.

- Pull the drain hose **23** from its holder and drain the dirty water via the drain hose.
- For transport of the vacuum cleaner, screw the plug cap **2** onto the hose connection piece **3**.

To prevent the formation of mould after wet vacuuming:

- Take out the flat-fold filter **30** and allow it to dry well.
- Remove the vacuum cleaner lid **13** open the filter cover **39** and allow both components to dry thoroughly.

## Filter Cleaning

### Automatic filter cleaning (see figure I)

In automatic filter cleaning mode (AFC = Automatic Filter Cleaning), the flat-fold filter **30** is cleaned every 15 seconds by means of air blasts (pulsating noise).

The filter cleaning system must be actuated latest when the vacuuming performance is no longer sufficient.

Regular use of the filter cleaning feature increases the tool life of the filter.

To achieve ideal filter tool life, deactivate the automatic filter cleaning in exceptional cases, e. g., when vacuuming pure liquids or when working with a paper filter bag.

A flat-fold filter contaminated only on the surface is fully functional. Manual cleaning of the flat-fold filter by striking/tapping against it or blowing it out is not necessary, and can even damage the filter.

**Note:** The automatic filter cleaning is factory-set. Switching the automatic filter cleaning on/off is only possible, when the VAC is running.

- **Deactivating the AFC**  
Actuate the AFC button **9**.  
The signalling LED **38** goes out.
- **Activating the AFC**  
Actuate the AFC button **9**.  
The signalling LED **38** lights up green.

## Maintenance and Service

### Maintenance and Cleaning

- ▶ **Before any work on the vacuum cleaner itself, pull the mains plug.**
- ▶ **For safe and proper working, always keep the vacuum cleaner and ventilation slots clean.**
- ▶ **Wear a dust protection mask when maintaining and cleaning the vacuum cleaner.**

If the replacement of the supply cord is necessary, this has to be done by Bosch or an authorized Bosch service agent in order to avoid a safety hazard.

A dust-technical inspection is to be carried out at least once every year by the manufacturer or an instructed person, e. g. for damage of the filter, tightness against leakage of the vacuum cleaner and function of the control/monitoring unit.

For category **M** vacuum cleaners that were in contaminated environments, the exterior as well as all machine parts should be cleaned or treated with sealants. When performing maintenance and repair work, all contaminated components that cannot be cleaned to satisfactory must be disposed of. Such components must be disposed of in impermeable plastic bags conforming with the valid regulations for the disposal of such waste.

For maintenance on behalf of the user, the vacuum cleaner must be disassembled, cleaned and maintained as far as feasible, without causing a risk for the maintenance personnel or other persons. Prior to disassembly, the vacuum cleaner should be cleaned in order to prevent any risks. The room/enclosure in which the vacuum cleaner is disassembled should

be well ventilated. Wear personal protective equipment during maintenance. After the maintenance, the maintenance area should be cleaned.

### Removing/Replacing the Flat-fold Filter (see figures J1 – J2)

- Replace a damaged flat-fold filter **30** immediately.
- Pull the locking latch **20** and open the filter cover **39**.
  - Grasp the flat-fold filter **30** by the fins, pull up and remove.
  - When taking out the flat-fold filter **30**, remove any accumulating dust and debris from the closing edge of the filter cover **39** using a moist cloth.
  - Gently strike/tap out the flat-fold filter **30**.  
PES and PTFE flat-fold filters can be flushed out under running water.
  - Insert a new or the cleaned flat-fold filter **30** observe proper and tight seating.
  - Shut the filter cover **39** again (must be heard to engage).

### Container

- Wipe out the container **1** from time to time with a commercially available, non-scouring cleaning agent and allow to dry.

### Level Sensors (see figure K)

Clean the level sensors **40** occasionally.

- Unlock the latches **15** and remove the vacuum lid **13**.
- Clean the level sensors **40** with a soft cloth.
- Reattach the vacuum lid **13** again and lock the latches **15**.

### Storage (see figure L)

- Wind the mains cable around the cable holder **14**.
- Insert the accessories into the holders provided: Vacuum tubes **35** in holders **22**, crevice nozzle **31** in holder **21**, floor nozzle **34** in holder **24**.
- Undue the elastic tie-downs of the vacuum-hose holders **4** and place the vacuum hose **27** around the vacuum cleaner lid into the holders **4**.  
Reattach the elastic tie-downs.
- Mount the L-Boxx onto the retainers **11**.
- For transport of the vacuum cleaner, screw the plug cap **2** onto the hose connection piece **3**.
- Store the vacuum cleaner in a dry room and secure it against unauthorised use.
- To lock the castors **18**, actuate the castor brakes **17** by pushing down.

### Transport (see figure M)

- Carry the vacuum cleaner only by the carrying handle **10**.
- Use the push handle **12** for moving the VAC around or pulling it over edges or obstacles.

## 24 | English

**Correction of Malfunctions**

Problem	Corrective Measure
The vacuum turbine does not start.	<ul style="list-style-type: none"> <li>- Check mains cable, mains plug, fuse, socket outlet and filling-level sensors <b>40</b>.</li> <li>Mode selector switch <b>7</b> set to 'Start/Stop automatic'.</li> <li>- Set mode selector switch <b>7</b> to the 'vacuum' symbol and switch the power tool connected to the socket outlet <b>5</b> on.</li> </ul>
Vacuum turbine switches off.	<ul style="list-style-type: none"> <li>- Empty container <b>1</b>.</li> </ul>
Vacuum turbine does not restart after emptying the container.	<ul style="list-style-type: none"> <li>- Switch vacuum cleaner off and wait 5 seconds" switch on again after 5 seconds.</li> <li>- Clean level indicators <b>40</b> as well as the space between the level indicators <b>40</b> with a brush.</li> </ul>
Vacuumping power decreases.	<ul style="list-style-type: none"> <li>- Remove clogs from vacuum nozzle, vacuum tubes <b>35</b>, vacuum hose <b>27</b> or flat-fold filter <b>30</b>.</li> <li>- Replace disposal bag <b>29</b> or dust bag.</li> <li>- Engage filter cover <b>39</b> properly.</li> <li>- Mount vacuum cleaner lid <b>13</b> properly and lock latches <b>15</b>.</li> <li>- Replace flat-fold filter <b>30</b>.</li> </ul>
Dust escapes during vacuuming	<ul style="list-style-type: none"> <li>- Check proper installation of the flat-fold filter <b>30</b>.</li> <li>- Replace flat-fold filter <b>30</b>.</li> </ul>
The automatic shut-off (wet vacuuming) does not respond.	<ul style="list-style-type: none"> <li>- Clean level indicators <b>40</b> as well as the space between the level indicators <b>40</b> with a brush.</li> </ul> <p>The automatic shut-off does not function with non-conductive liquids or foam/bubbles.</p> <ul style="list-style-type: none"> <li>- Monitor the level continuously.</li> </ul>
The alarm sounds.	<p>Vacuum capacity set too low.</p> <ul style="list-style-type: none"> <li>- Set control knob for vacuum capacity <b>8</b> to a higher value.</li> </ul> <p>Hose diameter is incorrectly set.</p> <ul style="list-style-type: none"> <li>- Set airflow regulator <b>6</b> to correct vacuum-hose diameter.</li> </ul> <p>Vacuum hose <b>27</b> clogged or bent/creased.</p> <ul style="list-style-type: none"> <li>- Correct clog or bend/crease.</li> </ul> <p>Disposal bag/dust bag full.</p> <ul style="list-style-type: none"> <li>- Replace disposal bag <b>29</b> or dust bag.</li> </ul> <p>Flat-fold filter <b>30</b> contaminated.</p> <ul style="list-style-type: none"> <li>- Clean flat-fold filter or replace, as required.</li> </ul> <p>Insufficient airflow for the connected power tool.</p> <ul style="list-style-type: none"> <li>- Open air diffuser <b>26</b> of the tool sleeve <b>25</b>: Turn ring on tool sleeve until air-diffuser opening is completely opened.</li> <li>- If available: Open air-diffuser opening of power tool.</li> </ul> <p>Malfunction of the monitoring electronics.</p> <ul style="list-style-type: none"> <li>- Contact an authorised service agent for Bosch power tools.</li> </ul>
Automatic filter cleaning inoperative.	<ul style="list-style-type: none"> <li>- Activate the filter cleaning (actuate the AFC button <b>9</b>).</li> <li>- Connect the vacuum hose <b>27</b>.</li> </ul>
The automatic filter cleaning cannot be switched off.	<ul style="list-style-type: none"> <li>- Contact an authorised service agent for Bosch power tools.</li> </ul>
The automatic filter cleaning cannot be switched off.	<ul style="list-style-type: none"> <li>- Contact an authorised service agent for Bosch power tools.</li> </ul>

**After-sales Service and Application Service**

In all correspondence and spare parts orders, please always include the 10-digit article number given on the type plate of the vacuum cleaner.

Our after-sales service responds to your questions concerning maintenance and repair of your product as well as spare parts. Exploded views and information on spare parts can also be found under: **www.bosch-pt.com**  
Bosch's application service team will gladly answer questions concerning our products and their accessories.