

WEU

WEU

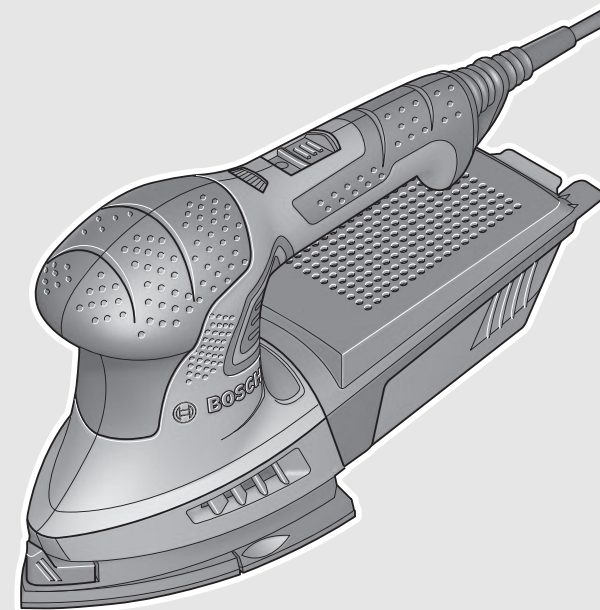

**Robert Bosch GmbH**  
Power Tools Division  
70745 Leinfelden-Echterdingen  
Germany

[www.bosch-pt.com](http://www.bosch-pt.com)

2 609 007 196 (2013.11) T / 70 WEU



2 609 007 196

**PSM 200 AES**

 **BOSCH**

**de** Originalbetriebsanleitung  
**en** Original instructions  
**fr** Notice originale  
**es** Manual original  
**pt** Manual original  
**it** Istruzioni originali  
**nl** Oorspronkelijke gebruiksaanwijzing

**da** Original brugsanvisning  
**sv** Bruksanvisning i original  
**no** Original driftsinstruks  
**fi** Alkuperäiset ohjeet  
**el** Πρωτότυπο οδηγιών χρήσης  
**tr** Orijinal işletme talimatı



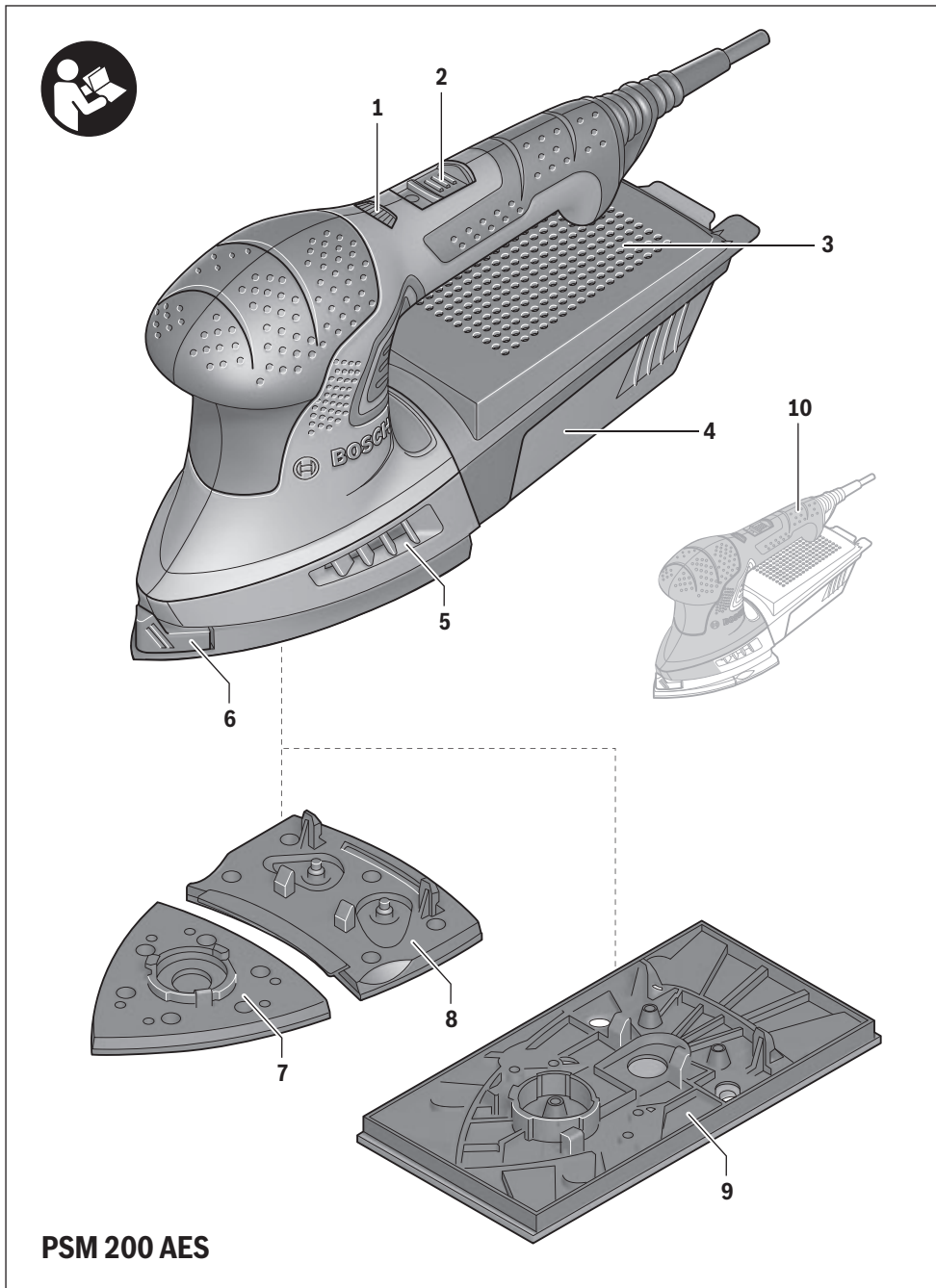

4 |

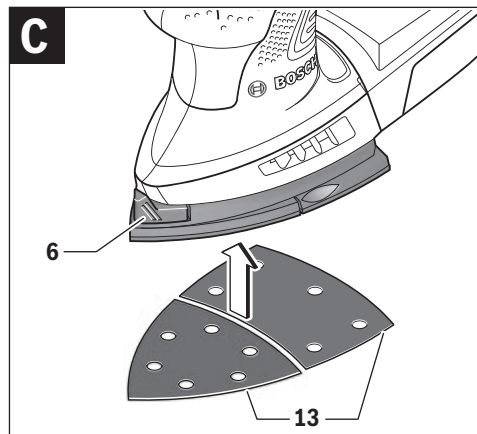
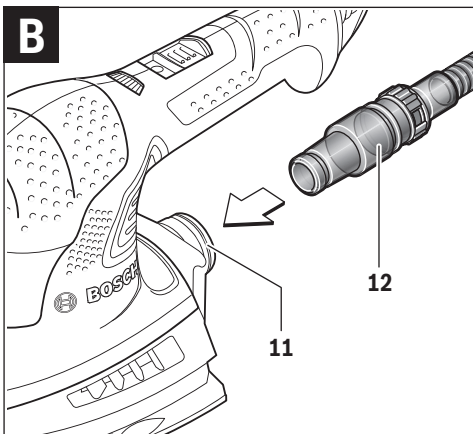
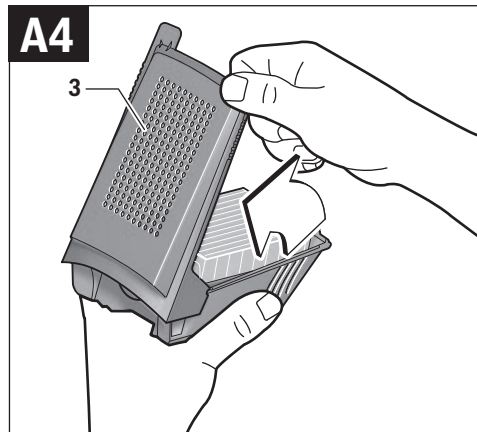
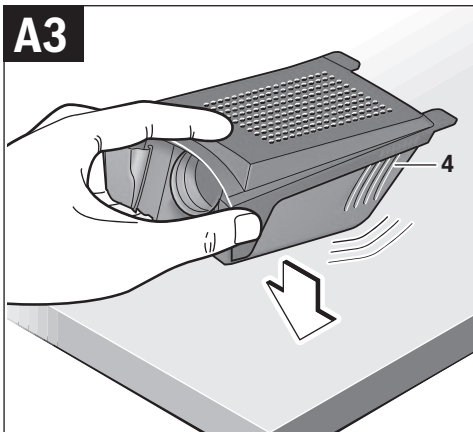
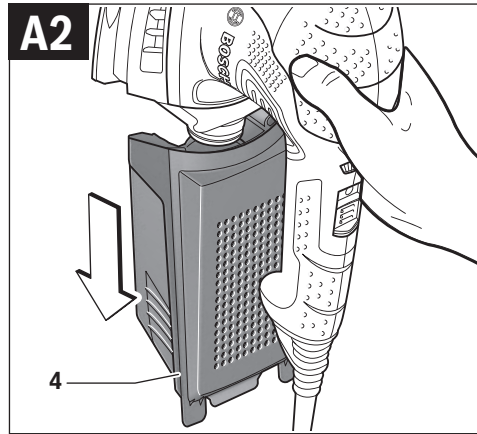
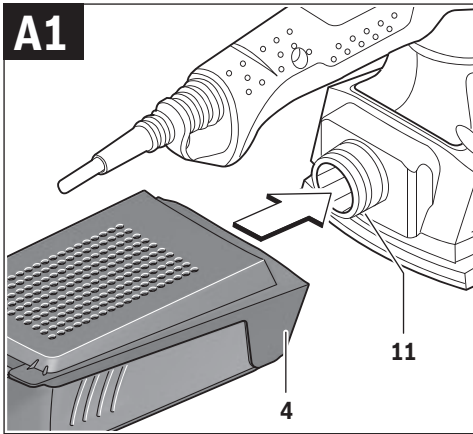

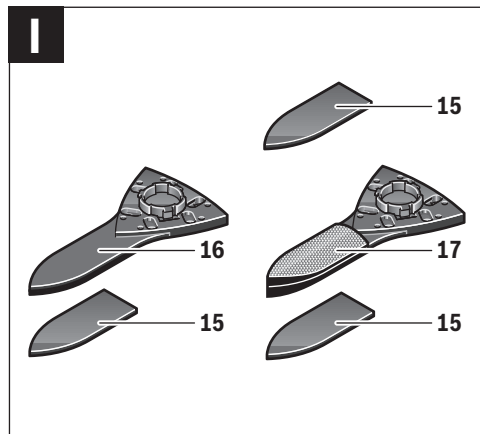
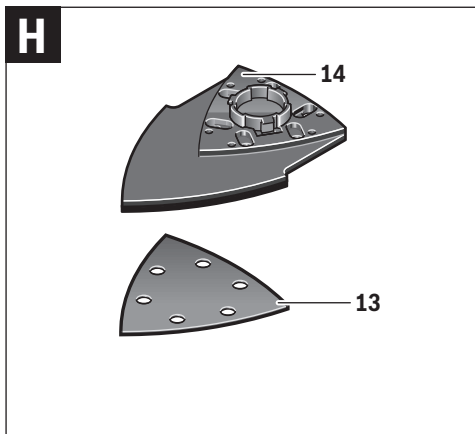
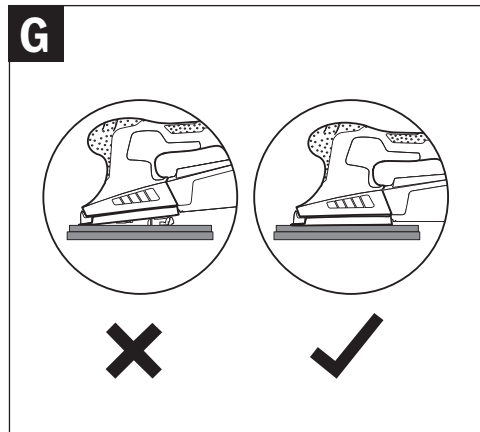
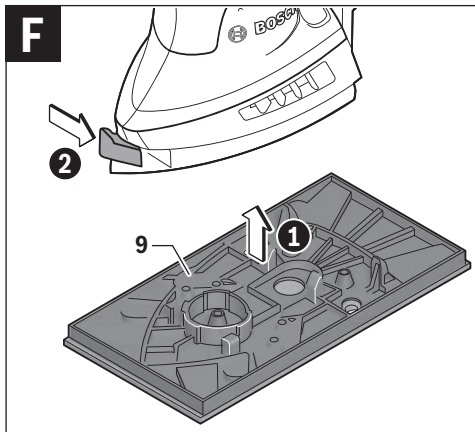
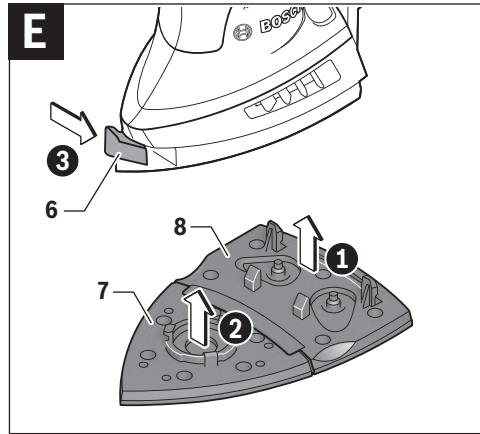
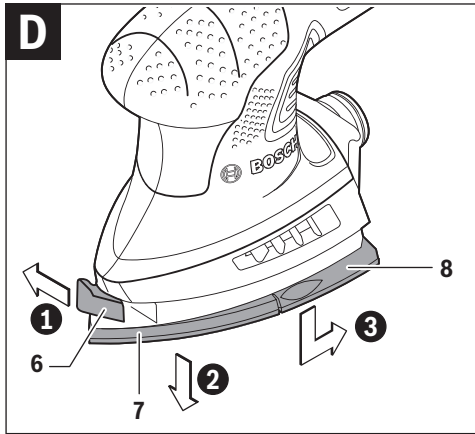

## English

### Safety Notes

#### General Power Tool Safety Warnings

**⚠ WARNING** Read all safety warnings and all instructions. Failure to follow the warnings and instructions may result in electric shock, fire and/or serious injury.

**Save all warnings and instructions for future reference.**

The term **power tool** in the warnings refers to your mains-operated (corded) power tool or battery-operated (cordless) power tool.

#### Work area safety

- ▶ **Keep work area clean and well lit.** Cluttered or dark areas invite accidents.
- ▶ **Do not operate power tools in explosive atmospheres, such as in the presence of flammable liquids, gases or dust.** Power tools create sparks which may ignite the dust or fumes.
- ▶ **Keep children and bystanders away while operating a power tool.** Distractions can cause you to lose control.

#### Electrical safety

- ▶ **Power tool plugs must match the outlet. Never modify the plug in any way. Do not use any adapter plugs with earthed (grounded) power tools.** Unmodified plugs and matching outlets will reduce risk of electric shock.
- ▶ **Avoid body contact with earthed or grounded surfaces, such as pipes, radiators, ranges and refrigerators.** There is an increased risk of electric shock if your body is earthed or grounded.
- ▶ **Do not expose power tools to rain or wet conditions.** Water entering a power tool will increase the risk of electric shock.
- ▶ **Do not abuse the cord. Never use the cord for carrying, pulling or unplugging the power tool. Keep cord away from heat, oil, sharp edges and moving parts.** Damaged or entangled cords increase the risk of electric shock.
- ▶ **When operating a power tool outdoors, use an extension cord suitable for outdoor use.** Use of a cord suitable for outdoor use reduces the risk of electric shock.
- ▶ **If operating a power tool in a damp location is unavoidable, use a residual current device (RCD) protected supply.** Use of an RCD reduces the risk of electric shock.

#### Personal safety

- ▶ **Stay alert, watch what you are doing and use common sense when operating a power tool. Do not use a power tool while you are tired or under the influence of drugs, alcohol or medication.** A moment of inattention while operating power tools may result in serious personal injury.
- ▶ **Use personal protective equipment. Always wear eye protection.** Protective equipment such as dust mask, non-skid safety shoes, hard hat, or hearing protection used for appropriate conditions will reduce personal injuries.

- ▶ **Prevent unintentional starting. Ensure the switch is in the off-position before connecting to power source and/or battery pack, picking up or carrying the tool.** Carrying power tools with your finger on the switch or energising power tools that have the switch on invites accidents.
- ▶ **Remove any adjusting key or wrench before turning the power tool on.** A wrench or a key left attached to a rotating part of the power tool may result in personal injury.
- ▶ **Do not overreach. Keep proper footing and balance at all times.** This enables better control of the power tool in unexpected situations.
- ▶ **Dress properly. Do not wear loose clothing or jewellery. Keep your hair, clothing and gloves away from moving parts.** Loose clothes, jewellery or long hair can be caught in moving parts.
- ▶ **If devices are provided for the connection of dust extraction and collection facilities, ensure these are connected and properly used.** Use of dust collection can reduce dust-related hazards.

#### Power tool use and care

- ▶ **Do not force the power tool. Use the correct power tool for your application.** The correct power tool will do the job better and safer at the rate for which it was designed.
- ▶ **Do not use the power tool if the switch does not turn it on and off.** Any power tool that cannot be controlled with the switch is dangerous and must be repaired.
- ▶ **Disconnect the plug from the power source and/or the battery pack from the power tool before making any adjustments, changing accessories, or storing power tools.** Such preventive safety measures reduce the risk of starting the power tool accidentally.
- ▶ **Store idle power tools out of the reach of children and do not allow persons unfamiliar with the power tool or these instructions to operate the power tool.** Power tools are dangerous in the hands of untrained users.
- ▶ **Maintain power tools. Check for misalignment or binding of moving parts, breakage of parts and any other condition that may affect the power tool's operation. If damaged, have the power tool repaired before use.** Many accidents are caused by poorly maintained power tools.
- ▶ **Keep cutting tools sharp and clean.** Properly maintained cutting tools with sharp cutting edges are less likely to bind and are easier to control.
- ▶ **Use the power tool, accessories and tool bits etc. in accordance with these instructions, taking into account the working conditions and the work to be performed.** Use of the power tool for operations different from those intended could result in a hazardous situation.

#### Service

- ▶ **Have your power tool serviced by a qualified repair person using only identical replacement parts.** This will ensure that the safety of the power tool is maintained.

## 12 | English

**Safety Warnings for Sander**

- ▶ **Use the machine only for dry sanding.** Penetration of water into the machine increases the risk of an electric shock.
- ▶ **Pay attention that no persons are put at risk through sparking. Remove any combustible materials in the vicinity.** Sparking occurs when sanding metal materials.
- ▶ **Caution, fire hazard! Avoid overheating the object being sanded as well as the sander. Always empty the dust collector before taking breaks.** In unfavourable conditions, e. g., when sparks emit from sanding metals, sanding debris in the dust bag, micro filter or paper sack (or in the filter sack or filter of the vacuum cleaner) can self-ignite. Particularly when mixed with remainders of varnish, polyurethane or other chemical materials and when the sanding debris is hot after long periods of working.
- ▶ **When working with the machine, always hold it firmly with both hands and provide for a secure stance.** The power tool is guided more secure with both hands.
- ▶ **Secure the workpiece.** A workpiece clamped with clamping devices or in a vice is held more secure than by hand.
- ▶ **Products sold in GB only:** Your product is fitted with a BS 1363/A approved electric plug with internal fuse (ASTA approved to BS 1362).  
If the plug is not suitable for your socket outlets, it should be cut off and an appropriate plug fitted in its place by an authorised customer service agent. The replacement plug should have the same fuse rating as the original plug.  
The severed plug must be disposed of to avoid a possible shock hazard and should never be inserted into a mains socket elsewhere.
- ▶ **Products sold in AUS and NZ only:** Use a residual current device (RCD) with a rated residual current of 30 mA or less.

**Product Description and Specifications**

**Read all safety warnings and all instructions.** Failure to follow the warnings and instructions may result in electric shock, fire and/or serious injury.

**Intended Use**

The machine is intended for dry sanding and polishing of wood, plastic, metal, filler, as well as for painted surfaces. It is especially suitable for profiles, corners or hard to reach locations.

**Product Features**

The numbering of the product features refers to the illustration of the machine on the graphics page.

- 1 Speed regulator
- 2 On/Off switch
- 3 Filter element (Microfilter System)
- 4 Dust box, complete (Microfilter System)

- 5 Ventilation openings
- 6 SDS button for release of the sanding plate
- 7 Front sanding plate
- 8 Rear sanding plate
- 9 Rectangular sanding plate
- 10 Handle (insulated gripping surface)
- 11 Extraction outlet
- 12 Vacuum hose\*
- 13 Sanding sheet\*
- 14 Pad extender\*
- 15 Sanding sheet for extender\*
- 16 Narrow pad extender\*
- 17 Narrow rounded pad extender\*

\*Accessories shown or described are not part of the standard delivery scope of the product. A complete overview of accessories can be found in our accessories program.

**Technical Data**

Multi Sander	PSM 200 AES	
Article number	3 603 CB6 0..	
Rated power input	W	200
No-load speed	min <sup>-1</sup>	3 000 13 000
No-load orbital stroke rate	min <sup>-1</sup>	6 000 26 000
Sanding sheet surface	cm <sup>2</sup>	104
Sanding sheet surface	rectangular cm <sup>2</sup>	164
Orbit diameter	mm	1.8
Weight according to EPTA-Procedure 01/2003	kg	1.4
Protection class	□ / II	

The values given are valid for a nominal voltage [U] of 230 V. For different voltages and models for specific countries, these values can vary.

Please observe the article number on the type plate of your machine.

The trade names of the individual machines may vary.

**Noise/Vibration Information**

	Two-part sanding plate	Rectangular sanding plate
Measured sound values determined according to EN 60745.		
Typically the A-weighted noise levels of the product are		
Sound pressure level	dB(A) 83	86
Sound power level	dB(A) 94	97
Uncertainty K	dB 3	3
<b>Wear hearing protection!</b>		
Vibration total values $a_h$ (triax vector sum) and uncertainty K determined according to EN 60745:		
$a_h$	m/s <sup>2</sup> 6.0	7.0
K	m/s <sup>2</sup> 1.5	1.5

The vibration level given in this information sheet has been measured in accordance with a standardised test given in EN 60745 and may be used to compare one tool with another. It may be used for a preliminary assessment of exposure.

The declared vibration emission level represents the main applications of the tool. However if the tool is used for different applications, with different accessories or insertion tools or is poorly maintained, the vibration emission may differ. This may significantly increase the exposure level over the total working period.

An estimation of the level of exposure to vibration should also take into account the times when the tool is switched off or when it is running but not actually doing the job. This may significantly reduce the exposure level over the total working period.

Identify additional safety measures to protect the operator from the effects of vibration such as: maintain the tool and the accessories, keep the hands warm, organisation of work patterns.

## Declaration of Conformity

We declare under our sole responsibility that the product described under Technical Data is in conformity with the following standards or standardization documents: EN 60745 according to the provisions of the directives 2011/65/EU, 2004/108/EC, 2006/42/EC.

Technical file (2006/42/EC) at:  
Robert Bosch GmbH, PT/ETM9,  
D-70745 Leinfelden-Echterdingen

Henk Becker	Helmut Heinzelmann
Executive Vice President	Head of Product Certification
Engineering	PT/ETM9

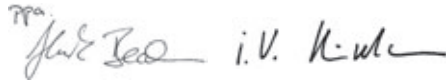

Robert Bosch GmbH, Power Tools Division  
D-70745 Leinfelden-Echterdingen  
Leinfelden, 30.10.2013

## Assembly

- ▶ **Before any work on the machine itself, pull the mains plug.**

### Dust/Chip Extraction

- ▶ Dusts from materials such as lead-containing coatings, some wood types, minerals and metal can be harmful to one's health. Touching or breathing-in the dusts can cause allergic reactions and/or lead to respiratory infections of the user or bystanders.

Certain dusts, such as oak or beech dust, are considered as carcinogenic, especially in connection with wood-treatment additives (chromate, wood preservative). Materials containing asbestos may only be worked by specialists.

As far as possible, use a dust extraction system suitable for the material.

Provide for good ventilation of the working place.

It is recommended to wear a P2 filter-class respirator.

Observe the relevant regulations in your country for the materials to be worked.

- ▶ **Prevent dust accumulation at the workplace.** Dusts can easily ignite.

### Integrated Dust Extraction with Dust Box (see Fig. A1 A4)

Attach the dust box **4** onto the extraction outlet **11** until it latches.

To empty the dust box **4**, pull off the dust box downward.

Before opening the dust box **4**, it is recommended to loosen the dust from the filter element by gently striking it against a firm support (as shown in the figure).

Grasp the dust box **4** by the recessed grip, fold the filter element **3** upward and empty the dust box. Clean the thin plates of the filter element **3** with a soft brush.

### External Dust Extraction (see figure B)

Mount a vacuum hose **12** onto the extraction outlet **11**. Connect the vacuum hose **12** with a vacuum cleaner. An overview for the connection of various vacuum cleaners can be found at the end of these instructions.

The vacuum cleaner must be suitable for the material being worked.

When vacuuming dry dust that is especially detrimental to health or carcinogenic, use a special vacuum cleaner.

### Replacing the Sanding Sheet (see figure C)

When attaching a new sanding sheet, remove any dust or debris from the sanding plate (e.g. with a brush).

To ensure optimum dust extraction, pay attention that the punched holes in the sanding sheet match with the holes in the sanding plate.

The sanding plate is fitted with Velcro backing for quick and easy fastening of sanding sheets with Velcro adhesion.

Before attaching the sanding sheets, free the sanding plate from any debris by tapping it in order to enable optimum adhesion.

- ▶ **Only use the machine when both sanding sheets are mounted.**

- ▶ **Only use sanding sheets with the same grain size.**

Position the sanding sheet **13** alongside one edge of the sanding plate **7** or **9** flush against it, then lay the sanding sheet onto the sanding plate and press firmly.

To remove the sanding sheet **13**, grasp it at one of the tips and pull it off from the sanding plate.

Sanding accessories, such as fleece pads/polishing cloth pads, are attached to the sanding plate in the same manner.



## 14 | English

**Selecting the Sanding Sheet**

Depending on the material to be worked and the required rate of material removal, different sanding sheets are available:

Application	Grain size	
For the working of all types of materials such as wood, paint, filler, lacquer, hard and soft wood as well as chip-boards and metal.	40	180
For coarse-sanding, e. g. of rough, unplanned beams and boards	coarse	40
For face sanding and planing small irregularities	medium	80, 120
For finish and fine sanding of hard woods	fine	180

For reworking or polishing, especially of metal and stone, use fleece/polishing cloth pad.

Depending on the desired surface quality of the workpiece, different fleece types or polishing cloth pads are to be used.

**Removing the two-part sanding plate (see figure D)**

- Slide the SDS button for release of the sanding plate **6** all the way to the right.
- Remove the sanding plate **7**.
- Pull the rear sanding plate **8** by the recessed grips downwards and then backwards.

If, e.g., the front tip of the sanding sheet is worn, you can also remove the complete sanding plate and reattach it turned by 120°.

**Attaching the two-part sanding plate (see figure E)**

- First, place the rear sanding plate **8** with the catch mechanisms on the recesses of the sanding plate holder. Press the sanding plate **8** onto the holder until you hear it click into place.
- Attaching the front sanding plate **7**.
- To fix the sanding plate, slide the SDS button for release of the sanding plate **6** all the way to the left.

**Attaching the rectangular sanding plate (see figures F G)**

- Place the sanding plate **9** with the catch mechanisms on the recesses of the sanding plate holder and press the sanding plate **9** onto the sanding plate holder, until you hear it click into place.
- To fix the sanding plate, slide the SDS button for release of the sanding plate **6** all the way to the left.
- Now check whether the rear part of the sanding plate is properly engaged by pressing on the rear right and left part of the rectangular sanding plate.

**Removing the rectangular sanding plate**

- Slide the SDS button for release of the sanding plate **6** all the way to the right.
- Remove the rectangular sanding plate **9**.

**Specialty Sanding Plates**

You can replace the supplied sanding plate with a specialty sanding plate, which is available as an accessory.

The specialty sanding plate is attached in the same manner as the one supplied.

Attach and remove the respective sanding sheets in the same manner as when changing original sanding sheets.

The operation of the specialty sanding plates is only permitted with a mounted rear sanding plate **8**.

**Pad Extender (see figure H)**

With the pad extender **14** you can sand surfaces that are difficult to access, such as sills on windows, cabinets or doors.

**Pad Extender, Narrow (see figure I)**

With the narrow pad extender **16** you can sand narrow openings, slots and passages.

The sanding sheet for the pad extender **15** is mounted like the front sanding sheet **13**.

**Pad Extender, Narrow Rounded (see figure I)**

The narrow rounded pad extender **17** allows you to sand curved and hollow areas or surfaces that are curved inward, such as on furniture, rails or heating radiators.

The sanding sheet for the pad extender **15** is mounted like the front sanding sheet **13**.

**Operation****Starting Operation**

- **Observe correct mains voltage! The voltage of the power source must agree with the voltage specified on the nameplate of the machine. Power tools marked with 230 V can also be operated with 220 V.**

**Switching On and Off**

To **start** the machine, push the On/Off switch **2** towards the front to **I**.

To **switch off** the machine, push the On/Off switch **2** towards the rear to **0**.

To save energy, only switch the power tool on when using it.

**Working Advice**

- **Before any work on the machine itself, pull the mains plug.**
- **Wait until the machine has come to a standstill before placing it down.**

With the speed regulator **1** you can preselect the required speed also during operation.

Select a low speed when polishing to avoid excessive heating of the surface.

The removal capacity during sanding is mainly determined by the selection of the sanding sheet.

Only flawless sanding sheets achieve good sanding capacity and extend the service life of the machine.

Pay attention to apply uniform sanding pressure; this increases the working life of the sanding sheets.



Intensifying the sanding pressure does not lead to an increase of the sanding capacity, but to increased wear of the machine and the sanding sheet.

For precise on-the-spot sanding of edges, corners and hard to reach areas, it is also possible to work only with the tip or an edge of the sanding plate.

A sanding sheet that has been used for metal should not be used for other materials.

Use only original Bosch sanding accessories.

## Maintenance and Service

### Maintenance and Cleaning

- ▶ **Before any work on the machine itself, pull the mains plug.**
- ▶ **For safe and proper working, always keep the machine and ventilation slots clean.**

If the replacement of the supply cord is necessary, this has to be done by Bosch or an authorized Bosch service agent in order to avoid a safety hazard.

### After-sales Service and Application Service

Our after-sales service responds to your questions concerning maintenance and repair of your product as well as spare parts. Exploded views and information on spare parts can also be found under:

**www.bosch-pt.com**

Bosch's application service team will gladly answer questions concerning our products and their accessories.

In all correspondence and spare parts order, please always include the 10-digit article number given on the type plate of the machine.

#### Great Britain

Robert Bosch Ltd. (B.S.C.)  
P.O. Box 98  
Broadwater Park  
North Orbital Road  
Denham  
Uxbridge  
UB 9 5HJ  
Tel. Service: (0844) 7360109  
Fax: (0844) 7360146  
E-Mail: boschservicecentre@bosch.com

#### Ireland

Origo Ltd.  
Unit 23 Magna Drive  
Magna Business Park  
City West  
Dublin 24  
Tel. Service: (01) 4666700  
Fax: (01) 4666888

#### Australia, New Zealand and Pacific Islands

Robert Bosch Australia Pty. Ltd.  
Power Tools  
Locked Bag 66  
Clayton South VIC 3169  
Customer Contact Center  
Inside Australia:  
Phone: (01300) 307044  
Fax: (01300) 307045  
Inside New Zealand:  
Phone: (0800) 543353  
Fax: (0800) 428570  
Outside AU and NZ:  
Phone: +61 3 95415555  
www.bosch.com.au

#### Republic of South Africa

##### Customer service

Hotline: (011) 6519600

##### Gauteng BSC Service Centre

35 Roper Street, New Centre  
Johannesburg  
Tel.: (011) 4939375  
Fax: (011) 4930126  
E-Mail: bsctools@icon.co.za

##### KZN BSC Service Centre

Unit E, Almar Centre  
143 Crompton Street  
Pinetown  
Tel.: (031) 7012120  
Fax: (031) 7012446  
E-Mail: bsc.dur@za.bosch.com

##### Western Cape BSC Service Centre

Democracy Way, Prosperity Park  
Milnerton  
Tel.: (021) 5512577  
Fax: (021) 5513223  
E-Mail: bsc@zsd.co.za

##### Bosch Headquarters

Midrand, Gauteng  
Tel.: (011) 6519600  
Fax: (011) 6519880  
E-Mail: rbsa-hq.pts@za.bosch.com

### Disposal

The machine, accessories and packaging should be sorted for environmental-friendly recycling.

Do not dispose of power tools into household waste!

#### Only for EC countries:



According to the European Directive 2012/19/EU for Waste Electrical and Electronic Equipment and its implementation into national right, power tools that are no longer usable must be collected separately and disposed of in an environmentally correct manner.

**Subject to change without notice.**