



# INSTRUCTIONS FOR Infra-Red Diesel Space Heater

Stock No.17111 Part No.DSH-IR-B

**IMPORTANT:** PLEASE READ THESE INSTRUCTIONS CAREFULLY TO ENSURE THE SAFE AND EFFECTIVE USE OF THIS PRODUCT.



**WARNING:**  
DO NOT place the heater on combustible or heat sensitive surfaces due to the nature of infra-red radiant heating the area in front of the heater will also become hot.



## GENERAL INFORMATION

These instructions accompanying the product are the original instructions. This document is part of the product, keep it for the life of the product passing it on to any subsequent holder of the product. Read all these instructions before assembling, operating or maintaining this product.

This manual has been compiled by Draper Tools describing the purpose for which the product has been designed, and contains all the necessary information to ensure its correct and safe use. By following all the general safety instructions contained in this manual, it will ensure both product and operator safety, together with longer life of the product itself.

All photographs and drawings in this manual are supplied by Draper Tools to help illustrate the operation of the product.

Whilst every effort has been made to ensure the accuracy of information contained in this manual, the Draper Tools policy of continuous improvement determines the right to make modifications without prior warning.

# 1. TITLE PAGE

---

## **1.1 INTRODUCTION:**

USER MANUAL FOR:  
Diesel Infra-Red Heaters  
Stock no. 17111.  
Part no. DSH-IR-B.

## **1.2 REVISIONS:**

---

Date first published May 2016

---

---

---

As our user manuals are continually updated, users should make sure that they use the very latest version.

Downloads are available from: <http://www.drapertools.com/manuals>

DRAPER TOOLS LIMITED  
HURSLEY ROAD  
CHANDLER'S FORD  
EASTLEIGH  
HAMPSHIRE  
SO53 1YF  
UK

WEBSITE: [drapertools.com](http://drapertools.com)  
PRODUCT HELPLINE: +44 (0) 23 8049 4344  
GENERAL FAX: +44 (0) 23 8026 0784

## **1.3 UNDERSTANDING THIS MANUALS SAFETY CONTENT:**

- DANGER!** Information that draws attention to the risk of injury or death.
- WARNING!** Information that draws attention to the risk of damage to the product or surroundings.
- CAUTION!** Information that draws attention to the risk which may result in minor injury or moderate damage.

## **1.4 COPYRIGHT © NOTICE:**

Copyright © Draper Tools Limited.  
Permission is granted to reproduce this publication for personal & educational use only.  
Commercial copying, redistribution, hiring or lending is prohibited.  
No part of this publication may be stored in a retrieval system or transmitted in any other form or means without written permission from Draper Tools Limited.

In all cases this copyright notice must remain intact.

---

# 2. CONTENTS

---

## 2.1 CONTENTS

	<b>PAGE</b>	<b>CONTENT</b>	<b>PAGE</b>
1		TITLE PAGE	
	1.1	INTRODUCTION .....	2
	1.2	REVISION HISTORY .....	2
	1.3	UNDERSTANDING THIS MANUAL .....	2
	1.4	COPYRIGHT NOTICE .....	2
2		CONTENTS	
	2.1	CONTENTS .....	3
3		GUARANTEE	
	3.1	GUARANTEE .....	4
4		INTRODUCTION	
	4.1	SCOPE .....	5
	4.2	SPECIFICATION .....	5
	4.3	HANDLING & STORAGE .....	5
5		HEALTH & SAFETY INFORMATION	
	5.1	GENERAL HEATER SAFETY WARNINGS .....	6-7
	5.2	CONNECTION TO THE POWER SUPPLY .....	8
6		TECHNICAL DESCRIPTION	
	6.1	IDENTIFICATION .....	9
7		UNPACKING & CHECKING	
	7.1	PACKAGING .....	10
8		PREPARING THE HEATER	
	8.1	HEAT DEFLECTOR .....	11
	8.2	FUELS .....	11
	8.3	FUELLING YOUR HEATER .....	11
	8.4	VENTILATION .....	11
9		OPERATING THE HEATER	
	9.1	TO START HEATER .....	12
	9.2	TO SHUT DOWN HEATER .....	12
	9.3	TO RESTART HEATER .....	12
	9.4	FUEL SYSTEM .....	12
	9.5	THE SAFETY SYSTEM .....	12
	9.6	STORING, TRANSPORTING OR SHIPPING .....	13
	9.7	DRAINING THE FUEL TANK .....	13
10		MAINTENANCE	
	10.1	FUEL TANK .....	14
	10.2	AIR INTAKE FILTER .....	14
	10.3	AIR OUTPUT FILTER, LINT FILTER .....	14
	10.4	FAN BLADES .....	14
	10.5	CLEAN PHOTOCELL .....	15
	10.6	FUEL FILTER .....	15
	10.7	SPARK PLUG .....	16
	10.8	PHOTOCELL .....	17
11		DISPOSAL	
	11.1	DISPOSAL .....	18
12		EXPLANATION OF SYMBOLS .....	18
		DECLARATION OF CONFORMITY .....	ENCLOSED

## 3. GUARANTEE

---

### 3.1 GUARANTEE

Draper tools have been carefully tested and inspected before shipment and are guaranteed to be free from defective materials and workmanship.

Should the tool develop a fault, please return the complete tool to your nearest distributor or contact Draper Tools Limited, Chandler's Ford, Eastleigh, Hampshire, SO53 1YF. England. Telephone Sales Desk: (023) 8049 4333 or Product Helpline (023) 8049 4344.

A proof of purchase must be provided with the tool.

If upon inspection it is found that the fault occurring is due to defective materials or workmanship, repairs will be carried out free of charge. This guarantee period covering parts/labour is 12 months from the date of purchase except where tools are hired out when the guarantee period is ninety days from the date of purchase. This guarantee does not apply to normal wear and tear, nor does it cover any damage caused by misuse, careless or unsafe handling, alterations, accidents, or repairs attempted or made by any personnel other than the authorised Draper warranty repair agent.

Note: If the tool is found not to be within the terms of warranty, repairs and carriage charges will be quoted and made accordingly.

This guarantee applies in lieu of any other guarantee expressed or implied and variations of its terms are not authorised.

Your Draper guarantee is not effective unless you can produce upon request a dated receipt or invoice to verify your proof of purchase within the guarantee period.

Please note that this guarantee is an additional benefit and does not affect your statutory rights.

Draper Tools Limited.

## 4. INTRODUCTION

---

### 4.1 SCOPE

This heater is designed to be used in open and, semi-open areas by means of combustion of Diesel or Kerosene fuel, and is electrically operated. Any other application is considered mis-use.

### 4.2 SPECIFICATION

Stock no .....	17111
Part no .....	DSH-IR-B
Motor:	
Rated voltage .....	230V~
Rated frequency .....	50Hz
Rated input .....	94W
Heat output .....	17kW-60,000BTU
Fuel .....	Diesel/Kerosene
Diesel consumption .....	1.39Ltrs/hr
Tank capacity .....	12Ltr
Weight .....	13.8kg
Dimensions .....	560x330x560mm

### 4.3 HANDLING & STORAGE

The environment will have a negative result on its operation if you are not careful. If the air is damp, components will rust. If the machine is unprotected from dust and debris; components will become clogged: And if not cleaned and maintained correctly or regularly the machine will not perform at its best.

## 5. HEALTH & SAFETY INFORMATION

---

### WARNING:

**DO NOT** place the heater on combustible or heat sensitive surfaces due to the nature of infra-red radiant heating the area in front of the heater will also become hot.

### 5.1 GENERAL HEATER SAFETY WARNINGS

**⚠ WARNING:** Read all safety warnings and all instructions. Failure to follow the warnings and instructions may result in electric shock, fire and/or serious injury.

Save all warnings and instructions for future reference.

- 1) **Work area safety**
  - a) **Keep work area clean and well lit.** Cluttered or dark areas invite accidents.
  - b) **Do not operate heaters in explosive atmospheres, such as in the presence of flammable liquids, gases or dust.** Heaters create sparks which may ignite the dust or fumes.
  - c) **Keep children and bystanders away while operating a heater.** Distractions can cause you to lose control.
- 2) **Electrical safety**
  - a) **Heaters plugs must match the outlet. Never modify the plug in any way. Do not use any adapter plugs with earthed (grounded) heaters.** Unmodified plugs and matching outlets will reduce risk of electric shock.
  - b) **Avoid body contact with earthed or grounded surfaces such as pipes, radiators, ranges and refrigerators.** There is an increased risk of electric shock if your body is earthed or grounded.
  - c) **Do not expose heaters to rain or wet conditions.** Water entering a heater will increase the risk of electric shock.
  - d) **Do not abuse the cord. Never use the cord for carrying, pulling or unplugging the heater. Keep cord away from heat, oil, sharp edges or moving parts.** Damaged or entangled cords increase the risk of electric shock.
  - e) **When operating a heater outdoors, use an extension cord suitable for outdoor use.** Use of a cord suitable for outdoor use reduces the risk of electric shock.
  - f) **If operating a heater in a damp location is unavoidable, use a residual current device (RCD) protected supply.** Use of an RCD reduces the risk of electric shock.
- 3) **Personal safety**
  - a) **Stay alert, watch what you are doing and use common sense when operating a heater. Do not use a heater while you are tired or under the influence of drugs, alcohol or medication.** A moment of inattention while operating heaters may result in serious personal injury.
  - b) **Use personal protective equipment. Always wear eye protection.** Protective equipment such as dust mask, non-skid safety shoes, hard hat, or hearing protection used for appropriate conditions will reduce personal injuries.
  - c) **Prevent unintentional starting. Ensure the switch is in the off position before connecting to power source.**
  - d) **Remove any adjusting key or wrench before turning the heater on.** A wrench or a key left attached to a rotating part of the heater may result in personal injury.
  - e) **Dress properly. Do not wear loose clothing or jewellery. Keep your hair, clothing and gloves away from moving parts.** Loose clothes, jewellery or long hair can get sucked into the in moving parts of the heater.
- 4) **Heater use and care**

**DO NOT** move the heater when it is in operation or when plugged into the mains supply. Only move heater once it has cooled and it has been unplugged.

  - a) **Use the correct heater for your application.** The correct heater will do the job better and safer at the rate for which it was designed.
  - b) **Do not use the heater if the switch does not turn it on and off.** Any heater that cannot be controlled with the switch is dangerous and must be repaired.
  - c) **Disconnect the plug from the power source before making any adjustments.** Such preventive safety measures reduce the risk of starting the heater accidentally.
  - d) **Store idle heater out of the reach of children and do not allow persons unfamiliar with the heater or these instructions to operate the power tool.** Heaters are dangerous in the hands of untrained users.
  - e) **Maintain heaters. Check for misalignment or binding of moving parts, breakage of parts and any other condition that may affect the heaters operation. If damaged, have the heater repaired before use.** Many accidents are caused by poorly maintained heaters.
  - g) **Use the heater, in accordance with these instructions, taking into account the working conditions and the work to be performed.** Use of the heater for operations different from those intended could result in a hazardous situation.
- 5) **Service**
  - a) **Have your heater serviced by a qualified repair person using only identical replacement parts.** This will ensure that the safety of the heater is maintained.

**WARNING:** ⚠

Diesel fuel is carcinogenic. Take care when transporting, refuelling and storage of diesel fuel. Always clean up fuel spills with regard to local legislative requirements.

# 5. HEALTH & SAFETY INFORMATION

---

**WARNING:** Heater must be stood on non-combustible surface (eg concrete) as the infra-red emitter will heat the area directly in front of the machine. If the heater is on a combustible surface there will be a danger of burning/fire.

**WARNING:** Before using this heater please read this OPERATING INSTRUCTION very carefully. This USER'S MANUAL has been designed to instruct you as to the proper manner in which to assemble, maintain, store, and most importantly, how to operate the heater in a safe and efficient manner.

**DANGER:** Improper use of this heater can result in serious injury or death from burns, fire, explosion, electrical shock, and/or carbon monoxide poisoning.

**WARNING: Risk of Burns/Fire/Explosion!**

- NEVER use fuels such as petrol, benzene, paint thinners, or other oil compounds in this heater (RISK OF FIRE OR EXPLOSION)
- NEVER use this heater where flammable vapours may be present
- NEVER refill the heater's fuel tank while heater is operating or still hot. This heater is EXTREMELY HOT while in operation
- Keep all combustible materials away from this heater.

Use only diesel or kerosene fuel according to EN 267. For details please refer to your fuel supplier or contact your dealer.

**WARNING:** Never leave the heater unattended while burning!

**WARNING: Risk of Indoor Air Pollution!**

- Use this heater only in well ventilated areas!
- Provide at least a three square foot (2,800 sq cm) opening of outside air for every 25,000Kcal/hr of heater rating.
- People with breathing problems should consult a physician before using the heater.
- Carbon Monoxide Poisoning: Early signs of carbon monoxide poisoning resemble flu-like symptoms such as headaches, dizziness, and/or nausea. If you have these symptoms, your heater may not be properly ventilated.

- Get fresh air at once!  
Some people are more affected by carbon monoxide than others. These include pregnant women, those with heart or lung problems, anaemia, or those under the influence of alcohol, or at high altitudes.
- Never use this heater in living or sleeping areas.

**WARNING: Risk of Electric Shock!**

Use only the electrical power (voltage and frequency) specified on the model plate of the heater. Use only a three-prong, earthed outlet and extension cord.

- ALWAYS install the heater so that it is not directly exposed to water spray, rain, dripping water, or wind.
- ALWAYS unplug the heater when not in use.

Minimum Clearances

Outlet .....8 feet (2.5m).  
Sides, Top and Rear .....4 feet (1.25m).

- NEVER block air inlet (rear) or air outlet (front) of heater.
- NEVER use duct work in front or at rear of.
- NEVER move or handle heater while still hot.
- NEVER transport heater with fuel in its tank.
- When used with integral thermostat, the heater may start at any time.
- ALWAYS locate heater on a stable and level non-combustible surface.
- ALWAYS keep children and animals away from heater.
- Use clean Diesel or 1-K kerosene in this heater. #1 fuel oil is a suitable substitute.
- Bulk fuel storage should be a minimum of 25ft from heaters, torches, portable generators, or other sources of ignition. All fuel storage should be in accordance with National, state, or local authorities.

## 5. HEALTH & SAFETY INFORMATION

---

### 5.2 CONNECTION TO THE POWER SUPPLY

**CAUTION: Risk of electric shock. Do not open.**

This appliance is supplied with a moulded 3 pin mains plug for your safety. The value of the fuse fitted is marked on the pin face of the plug. Should the fuse need replacing, ensure the substitute is of the correct rating, approved to BS1362 and ASTA or BS Kite marked.

ASTA 

BSI 

The fuse cover is removable with a small plain slot screwdriver. Ensure the fuse cover is replaced before attempting to connect the plug to an electrical outlet. If the cover is missing, a replacement must be obtained or the plug replaced with a suitable type.

If a replacement plug is to be fitted this must be carried out by a qualified electrician.

The damaged or incomplete plug, when cut from the cable shall be disabled to prevent connection to a live electrical outlet.

This appliance must be earthed.

This appliance is Class I<sup>†</sup> and is designed for connection to a power supply matching that detailed on the rating label and compatible with the plug fitted.

If an extension lead is required, use an approved and compatible lead rated for this appliance. Follow all the instruction supplied with the extension lead.

<sup>†</sup>Earthed : This product requires an earth connection to protect against electric shock from accessible conductive parts in the event of a failure of the basic insulation.



## 6. TECHNICAL DESCRIPTION

---

### 6.1 IDENTIFICATION



- ① Infra-red panel
- ② Grill
- ③ Handle (carry)
- ④ Lamp
- ⑤ Thermostat dial
- ⑥ Temp window

- ⑦ Power switch
- ⑧ Power cable
- ⑨ Fuel cap
- ⑩ Fuel tank
- ⑪ Fuel gauge

## 7. UNPACKING & CHECKING

---

### **7.1 PACKAGING**

Carefully remove the product from the packaging and examine it for any sign of damage that may have happened during shipping. Lay the contents out and check them against the parts list provided. If any part is damaged or missing; please contact the Draper Helpline (the telephone number appears on the Title page) and do not attempt to use the product.

The packaging material should be retained at least during the guarantee period: in case the heater needs to be returned for repair.

**Warning!** Some of the packaging materials used may be harmful to children. Do not leave any of these materials in the reach of children.

If any of the packaging is to be thrown away, make sure they are disposed of correctly; according to local regulations.

## 8. PREPARING THE HEATER

---

### 8.2 FUELS

Use only standard clean Diesel or Kerosene heater oil according to EN 267.

**WARNING:** Never use petrol, oil, used oils, naphtha, paint thinners, alcohol or other highly flammable fuels. Using incorrect fuel may cause danger of explosion and death.

**IMPORTANT:** Be sure fuel tank is clean. Foreign matter such as rust, dirt, or water will cause the ignition control assembly to shut down heater. Foreign matter may also require heater's fuel system to be frequently cleaned.

**WARNING:** Do not fill the fuel tank while the heater is running.

**NOTE:** Diesel or Kerosene should only be stored in a black container that is clearly marked "diesel or kerosene". Never store diesel or kerosene in a red container. Red is associated with petrol.

- NEVER store diesel or kerosene in the living space. Diesel or kerosene should be stored in a well ventilated area outside the living area.
- NEVER use fuel such as petrol, benzene, alcohol, white gas, camp stove fuel, paint thinners, or other oil compounds in this heater (THESE ARE VOLATILE FUELS THAT CAN CAUSE A FIRE OR EXPLOSION).
- NEVER store diesel or kerosene in direct sunlight or near a source of heat.
- NEVER use diesel or kerosene that has been stored from one season to the next. Kerosene deteriorates over time. OLD DIESEL OR KEROSENE WILL NOT BURN PROPERLY IN THIS HEATER.

### 8.3 FUELLING YOUR HEATER

Never fill the heater fuel tank in the living space: fill the tank outdoors.

Do not overfill your heater and be sure heater is level.

**WARNING:** Never refill fuel tank when heater is operating or still hot.

### 8.4 VENTILATION

**CAUTION:** Risk of indoor air pollution. DANGER OF DEATH. Use heater only in well ventilated areas

Provide a fresh air opening of at least three (3) square feet (2,800 sq. cm) for each 30,000 kcal/Hr. rating. Provide extra fresh air if more heaters are being used.

Example: A heater requires one of the following:

1. A two-car garage door raised six inches (15.24 cm).
2. A single-car garage door raised nine inches (22.86 cm).
3. Two, thirty inch (76.20 cm) windows raised fifteen inches (38.1 cm).

**WARNING:** Never try to use the heater for the purpose of heating residential rooms.

# 9. OPERATING THE HEATER

---

## 9.1 TO START HEATER - FIG. 4

**WARNING: Ensure the heater is stood on a NON-COMBUSTIBLE SURFACE!**

- i. Fill fuel tank with appropriate fuel.
- ii. Fit fuel cap.
- iii. Plug power cable into mains supply.
  - Extension Cable Wire Size Requirements:
    - 6 to 10 feet (1.8 to 3 metres) long, use 1.0mm gauge cable.
    - 11 to 100 feet (3.4 to 30.53 metres) long, use 1.3mm gauge cable.
    - 101 to 200 feet (30.8 to 61 metres) long, use 1.6mm gauge cable.
- iv. Turn THERMOSTAT CONTROL (5) to desired setting and press power switch to "ON" position. Power indicator lamp will light and heater will start.

If heater does not start, the thermostat setting may be too low. Turn THERMOSTAT CONTROL (5) to higher position to start heater. If heater still does not start, turn power switch to OFF and then to ON position.

## 9.2 TO SHUT DOWN HEATER

Turn power switch to "OFF" and allow heater fan to cool unit. Once the cooling fan has stopped you may then unplug the power cable.

**WARNING:** Do not unplug power cable until fan has stopped as the combustion chamber MUST be cooled.

## 9.3 TO RESTART HEATER

- i. Wait 10 seconds after stopping heater.
- ii. Repeat steps under, "TO START HEATER."

## 9.4 FUEL SYSTEM

This heater is equipped with an electric pump that is connected to the fuel intake, and then through a nozzle in the burner head.

This fuel is then sprayed into the combustion chamber in a fine mist.

The electronic ignitor sends voltage to a specially designed spark plug. The spark plug ignites the fuel mixture described.

The motor turns a fan that forces air into and around the combustion chamber, which warms the heater plate, emitting infra-red heat.

## 9.5 THE SAFETY SYSTEM

**Temperature Limit Control:** This heater is equipped with a Temperature Limit Control designed to turn the heater off should the internal temperature rise to an unsafe level. If this device activates and turns your heater off, it may require service.

Once the temperature falls below the reset temperature, you will be able to start your heater.

**Electrical System Protection:** This heater's electrical system is protected by a fuse mounted to the PCB Assembly that protects it and other electrical components from damage. If your heater fails to operate, have this fuse checked first and replace as needed.

**Flame-Out Sensor:** Utilizes a photocell to monitor the flame in burn chamber during normal operation. It will cause the heater to shut off should the burner flame extinguish.

**Tip-over sensor:** If the unit is tipped or pushed over during use, the unit will shut down immediately and NOT re-start until it is totally cooled. Always ensure that the heater is on a stable, non-combustible surface and away from any risk that it could be tipped or pushed-over.

## 9. OPERATING THE HEATER

---

### ***9.6 STORING, TRANSPORTING OR SHIPPING***

CAUTION: Fuel tank MUST be empty before shipping or transportation.

### ***9.7 DRAINING THE FUEL TANK:***

Place a suitable size container under the heater - remove the fuel cap (9) and empty out fuel.

If any debris is noted in old fuel, add 1 or 2 litres of clean fuel into tank, wash around and drain again. This will prevent excess debris from clogging the filters during future use.

Replace fuel cap. Properly dispose of old and dirty fuel in line with local disposal regulations.

DO NOT dispose of old fuel into a main drains - this is illegal.

Before storing, drain the fuel tank empty and clean the heater as described in the maintenance section. Store the heater in a dry place away from children. Make sure the storage place is free of dust and corrosive fumes.

# 10. MAINTENANCE

**WARNING:** Do not repair the product when the heater is hot or the power supply is connected.

## 10.1 CLEAN FUEL TANK

Clean the tank every 200 hours or when necessary. When cleaning, use diesel or kerosene not water and after cleaning dry completely.

## 10.2 CLEAN FILTER

Clean by rinsing out with kerosene or diesel etc twice a year. If used with contaminated fuel, you should clean right away.

## 10.3 CLEAN FAN - FIGS. 1 - 2

**Warning!** Never repair the product when the fan is running or power supply is connected. The fan should be cleaned once a year. Clean both the ventilating fan on the burner and the cooling fan over the tank. Clean each fan with a wet cloth do not break or bend, then dry and assemble.

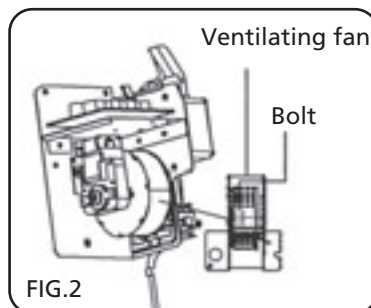
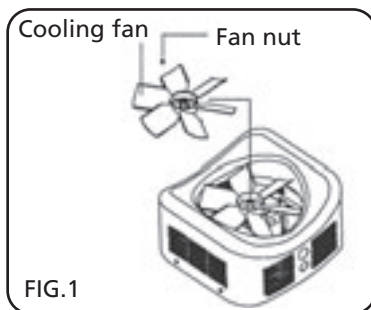

## 10.4 CLEAN NOZZLE - FIG. 3

Nozzle should be cleaned or exchanged minimum once a year. If used with contaminated fuel, it needs to be changed right away. To clean the nozzle, take it out of the burner, disassemble clean and carefully assemble.

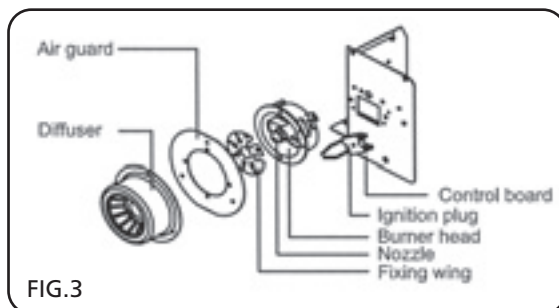

# 10. MAINTENANCE

## 10.5 CLEAN IGNITION PLUG - FIG. 4

Ignition plug should be cleaned or its gap should be adjusted every 600 hours of use or when necessary. Clean by a wire brush after taking the ignition plug out of the burner. Electrode gap should be between 3.5~3.7mm.

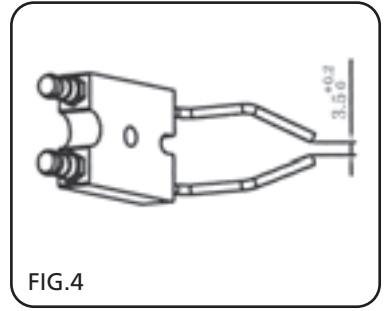

FIG.4

## 10.6 CLEAN PHOTOELECTRIC CELL - FIG. 5

Photoelectric cell should be cleaned once a year or when necessary. Clean the photoelectric cell face gently with cotton moistened in water or alcohol.

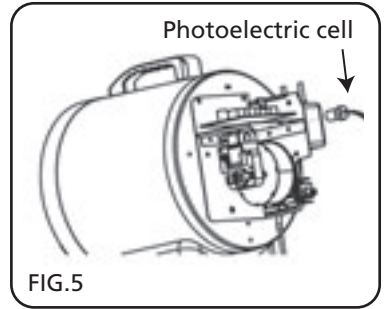

FIG.5

## 10.7 LONG TERM STORAGE

1. Open the fuel cap.
  2. Remove all fuel.
  2. Clean the tank inside by using diesel or kerosene, never use water.
  4. Completely dry the tank.
- Never store with fuel in the fuel tank.  
Long term storage with fuel will damage the heater.  
Keep in a dried and well ventilated place.  
Keep the product in a place without dust and humidity.  
Keep the manual in a place where it is easy to find.

# 10. MAINTENANCE

## 10.8 MACHINE ERROR CODES.

Machine error codes appear in the temperature indication window.

CODE		REASON	CORRECTIVE ACTION
E0	Power supply switch manipulation error.	Machine switch in "on" position when plugged in.	Turn off the power supply then turn off the switch, and turn on the power supply then turn on the machine.
E1	Flame detector (photo cell tube error).	1. Fuel shortage.	Add fuel.
		2. Photocell faulty	Clean or replace photocell.
		3. Imperfect combustion	Remove fuel and add clean fuel.
		4. Photocell contaminated	Remove and clean photocell.
		5. Blocked / contaminated fuel filter	Clean or replace.
		6. Ignition fault	1. Check ignition plug cable 2. Clean and re-gap ignition plug
E2	Temperature perception sensor error.	1. Temperature sensor terminal disconnected	Re-connect temperature sensor
		2. Thermostat faulty	Replace thermostat
E3	Overheating prevention sensor error/ conductive sensor check	1. Abnormal overheating	Switch unit off, allow fan to cool the machine and leave 15 minutes before attempting re-start
		2. Product tipped or overturned	Ensure heater is on a flat, stable surface
LO		In case of below -9°C	Normal state
Cn		On going combustion	Normal state



# 11. DISPOSAL

---

## 11.1 DISPOSAL

- At the end of the machine's working life, or when it can no longer be repaired, ensure that it is disposed of according to national regulations.
- Contact your local authority for details of collection schemes in your area.

In all circumstances:

- Do not dispose of power tools with domestic waste.
- Do not incinerate.
- Do not abandon in the environment.
- Do not dispose of WEEE\* as unsorted municipal waste.



\* Waste Electrical & Electronic Equipment.

## 12. EXPLANATION OF SYMBOLS

---



WEEE

Do not dispose of Waste Electrical  
& Electronic Equipment in with  
domestic rubbish



- **DRAPER TOOLS LIMITED,**  
Hursley Road, Chandler's Ford,  
Eastleigh, Hampshire. SO53 1YF. U.K.
- **Helpline:** (023) 8049 4344
- **Sales Desk:** (023) 8049 4333
- **General Enquiries:** (023) 8026 6355
- **Service/Warranty Repair Agent**  
For aftersales servicing or warranty repairs, please  
contact the Draper Tools Helpline for details of an  
agent in your local area.

YOUR DRAPER STOCKIST

DKMC0516

