

# DRAPER®

## INSTRUCTIONS FOR 230V 100L Belt Driven Air Compressor

Stock No.31254 Part No.DA100/330

**IMPORTANT:** PLEASE READ THESE INSTRUCTIONS CAREFULLY TO ENSURE THE SAFE AND EFFECTIVE USE OF THIS PRODUCT.



DRAPER®

### GENERAL INFORMATION

These instructions accompanying the product are the original instructions. This document is part of the product, keep it for the life of the product passing it on to any subsequent holder of the product. Read all these instructions before assembling, operating or maintaining this product.

This manual has been compiled by Draper Tools describing the purpose for which the product has been designed, and contains all the necessary information to ensure its correct and safe use. By following all the general safety instructions contained in this manual, it will ensure both product and operator safety, together with longer life of the product itself.

All photographs and drawings in this manual are supplied by Draper Tools to help illustrate the operation of the product. Whilst every effort has been made to ensure the accuracy of information contained in this manual, the Draper Tools policy of continuous improvement determines the right to make modifications without prior warning.

# 1. TITLE PAGE

---

## 1.1 INTRODUCTION:

USER MANUAL FOR:

### 230V 100L BELT DRIVEN AIR COMPRESSOR

Stock no. 31254

Part no. DA100/330

## 1.2 REVISIONS:

---

Date first published April 2013

---

---

---

---

As our user manuals are continually updated, users should make sure that they use the very latest version.

Downloads are available from: <http://www.drapertools.com/b2c/b2cmanuals.pgm>

DRAPER TOOLS LIMITED  
HURSLEY ROAD  
CHANDLER'S FORD  
EASTLEIGH  
HAMPSHIRE  
SO53 1YFUK

WEBSITE: [www.drapertools.com](http://www.drapertools.com)  
PRODUCT HELPLINE: +44 (0) 23 8049 4344  
GENERAL FAX: +44 (0) 23 8026 0784

## 1.3 UNDERSTANDING THIS MANUALS SAFETY CONTENT:

**WARNING!** Information that draws attention to the risk of injury or death.

**CAUTION!** Information that draws attention to the risk of damage to the product or surroundings.

## 1.4 COPYRIGHT © NOTICE:

Copyright © Draper Tools Limited.

Permission is granted to reproduce this publication for personal & educational use only. Commercial copying, redistribution, hiring or lending is prohibited.

No part of this publication may be stored in a retrieval system or transmitted in any other form or means without written permission from Draper Tools Limited.

In all cases this copyright notice must remain intact.

# 2. CONTENTS

---

## 2.1 CONTENTS

	<b>PAGE CONTENT</b>	<b>PAGE</b>
1	TITLE PAGE	
	1.1 INTRODUCTION .....	2
	1.2 REVISION HISTORY.....	2
	1.3 UNDERSTANDING THIS MANUAL .....	2
	1.4 COPYRIGHT NOTICE .....	2
2	CONTENTS	
	2.1 CONTENTS .....	3
3	GUARANTEE	
	3.1 GUARANTEE .....	4
4	INTRODUCTION	
	4.1 SCOPE .....	5
	4.2 SPECIFICATION .....	5
	4.3 HANDLING & STORAGE .....	5
5	HEALTH & SAFETY INFORMATION	
	5.1 GENERAL SAFETY INSTRUCTIONS FOR POWER TOOL USE .....	6
	5.2 ADDITIONAL SAFETY INSTRUCTIONS FOR SAFETY VALVES .....	8
	5.3 ADDITIONAL SAFETY INSTRUCTIONS FOR PRESSURE VESSELS.....	9A
	5.4 CONNECTION TO THE POWER SUPPLY .....	9A
6	TECHNICAL DESCRIPTION	
	6.1 IDENTIFICATION .....	10B
7	UNPACKING & CHECKING	
	7.1 PACKAGING.....	10A
	7.2 WHAT'S IN THE BOX .....	10A
8	ASSEMBLY & PREPARATION	
	8.1 FITTING THE WHEELS .....	11
	8.2 FITTING THE RUBBER ANTI-VIBRATION FOOT .....	11
	8.3 ASSEMBLING THE HANDLE .....	11
	8.4 FITTING THE AIR FILTER .....	11
	8.5 FILLING WITH OIL .....	12
	8.6 FINAL CHECKS PRIOR TO USE .....	12
9	OPERATING THE COMPRESSOR	
	9.1 BASIC COMPRESSOR OPERATION .....	13
	9.2 SAFETY VALVE.....	14
	9.3 ADJUSTING THE PRESSURE SWITCH .....	14
	9.4 OVERLOAD CUT-OUT.....	14
	9.5 MOISTURE IN COMPRESSED AIR .....	15
	9.6 STORAGE .....	15
10	TROUBLESHOOTING .....	16
11	MAINTENANCE	
	11.1 OPERATIONS TO BE CARRIED OUT AFTER THE FIRST 50 WORKING HOURS .....	17
	11.2 WEEKLY OPERATIONS .....	17
	11.3 MONTHLY OPERATIONS (OR MORE FREQUENTLY IF THE COMPRESSOR OPERATES IN VERY DUSTY CONDITIONS). .....	17
	11.4 OPERATIONS TO BE CARRIED OUT EVERY 6 MONTHS .....	18
	11.5 OPERATIONS TO BE CARRIED OUT EVERY 2 YEARS .....	18
	11.6 RECOMMENDED OILS .....	18
12	EXPLANATION OF SYMBOLS	
	12.1 EXPLANATION OF SYMBOLS .....	19
13	DISPOSAL	
	13.1 DISPOSAL .....	20
14	GLOSSARY	
	14.1 GLOSSARY .....	21
	DECLARATION OF CONFORMITY .....	ENCLOSED

## 3. GUARANTEE

---

### 3.1 *GUARANTEE*

Draper tools have been carefully tested and inspected before shipment and are guaranteed to be free from defective materials and workmanship.

Should the tool develop a fault, please return the complete tool to your nearest distributor or contact Draper Tools Limited, Chandler's Ford, Eastleigh, Hampshire, SO53 1YF. England. Telephone Sales Desk: (023) 8049 4333 or Product Helpline (023) 8049 4344.

A proof of purchase must be provided with the tool.

If upon inspection it is found that the fault occurring is due to defective materials or workmanship, repairs will be carried out free of charge. This guarantee period covering parts/labour is 12 months from the date of purchase except where tools are hired out when the guarantee period is ninety days from the date of purchase. This guarantee does not apply to normal wear and tear, nor does it cover any damage caused by misuse, careless or unsafe handling, alterations, accidents, or repairs attempted or made by any personnel other than the authorised Draper warranty repair agent.

Note: If the tool is found not to be within the terms of warranty, repairs and carriage charges will be quoted and made accordingly.

This guarantee applies in lieu of any other guarantee expressed or implied and variations of its terms are not authorised.

Your Draper guarantee is not effective unless you can produce upon request a dated receipt or invoice to verify your proof of purchase within the guarantee period.

Please note that this guarantee is an additional benefit and does not affect your statutory rights.

**Draper Tools Limited.**

## 4. INTRODUCTION

---

### 4.1 SCOPE

The compressor described in this manual is capable of supplying compressed air to a maximum pressure of 8bar. to operate pneumatic tools for a variety of applications including blowing, spraying and tyre inflating.

### 4.2 SPECIFICATION

Stock No. ....	31254
Part No. ....	DA100/330
Motor:	
Rated voltage .....	230V
Rated frequency .....	50Hz
Rated input .....	2200W (3HP)
Revolutions per minute (no load) .....	1,100min-1
Maximum working pressure .....	116psi (8bar)
Air displacement .....	10.2cfm (290L/min)
Free air delivery .....	8.1cfm (230L/min)
Receiver capacity.....	100 Litres
Sound power level .....	97dB(A)
Sound pressure level .....	77dB(A)
*Single value noise level.....	95dB(A)
Dimensions (LxWxH) .....	1080x420x810mm
Weight .....	75kg

### 4.3 HANDLING & STORAGE

This compressor is designed to be moved to different locations. Ensure it is always operated on a level surface. When in transit care should be taken not to cause damage particularly to gauges and air lines.

\*A-Weighed sound power level in accordance to 2000/14/EC

## 5. HEALTH & SAFETY INFORMATION

---

### 5.1 GENERAL SAFETY INSTRUCTIONS FOR POWER TOOL USE

When using any type of power tool there are steps that should be taken to make sure that you, as the user, remain safe.

Common sense and a respect for the tool will help reduce the risk of injury.

**Read the instruction manual fully.** Do not attempt any operation until you have read and understood this manual.

Most important you must know how to safely start and stop this machine, especially in an emergency.

**Keep the work area tidy and clean.** Attempting to clear clutter from around the machine during use will reduce your concentration. Mess on the floor creates a trip hazard. Any liquid spilt on the floor could result in you slipping.

**Find a suitable location.** If the machine is bench mounted; the location should provide good natural light or artificial lighting as a replacement. Avoid damp and dust locations as it will have a negative effect on the machine's performance.

If the machine is portable; do not expose the tool to rain. In all cases do not operate power tools near any flammable materials.

**Beware of electric shock.** Avoid contact with earthed surfaces; because they can conduct electricity if there is an electrical fault with the power tool. Always protect the power cable and route it away from danger.

**Keep bystanders away.** Children, onlookers and passers by must be restricted from entering the work area for their own protection. The barrier must extend a suitable distance from the tool user.

**Unplug and house all power tools that are not in use.** A power tool should never be left unattended while connected to the power supply. They must be housed in a suitable location, locked up and away from children.

**Do not overload or misuse the tool.** All tools are designed for a purpose and are limited to what they are capable of doing. Do not attempt to use a power tool (or adapt it in any way) for an application it is not designed for. Select a tool appropriate for the size of the job. Overloading a tool will result in tool failure and user injury: This covers the use of accessories.

**Dress properly.** Loose clothing, long hair and jewellery are all dangerous because they can become entangled in moving machinery: This can also result in parts of body being pulled into the machine.

Clothing should be close fitted, with any long hair tied back and jewellery and neck ties removed. Footwear must be fully enclosed and have a nonslip sole.

## 5. HEALTH & SAFETY INFORMATION

---

**Wear personal protective equipment (PPE).** Dust, noise, vibration and **swarf** can all be dangerous if not suitably protected against. If the work involving the power tool creates dust or fumes; wear a dust mask. Vibration to the hand, caused by operating some tools for longer periods must be protected against. Wear vibration reducing gloves and allow long breaks between uses. Protect against dust and **swarf** by wearing approved safety goggles or a face shield. These are some of the more common hazards and preventions; however, always find out what hazards are associated with the machine/work process and wear the most suitable protective equipment available.

**Do not breathe contaminated air.** If the work creates dust or fumes; connect the machine (if possible) to an extraction system either locally or remotely. Working outdoors can also help if possible.

**Move the machine as instructed.** If the machine is hand held, do not carry it by the power supply cable. If the product is heavy; employ a second or third person to help move it safely or use a mechanical device. Always refer to the instructions for the correct method.

**Do not overreach.** Extending your body too far can result in a loss of balance and you falling. This could be from a height or onto a machine and will result in injury.

**Maintain your tools correctly.** A well maintained tool will do the job safely. Replace any damaged or missing parts immediately with original parts from the manufacturer. As applicable; keep blades sharp; moving parts clean, oiled or greased; handles clean; and emergency devices working.

**Wait for the machine to stop.** Unless the machine is fitted with a safety brake; some parts may continue to move due to momentum. Wait for all parts to stop; then unplug it from the power supply before making any adjustments, carrying out maintenance operations or just finishing using the tool.

**Remove and check setting tools.** Some machinery requires the use of additional tools or keys to set, load or adjust the power tool. Before starting the power tool always check to make certain they have been removed and are safely away from the machine.

**Prevent unintentional starting.** Before plugging any machine in to the power supply, make sure the switch is in the OFF position. If the machine is portable; do not hold the machine near the switch and take care when putting the machine down; that nothing can operate the switch.

**Carefully select an extension lead.** Some machines are not suitable for use with extension leads. If the tool is designed for use outdoors; use an extension lead also suitable for that environment. When using an extended lead, select one capable of handling the current (amps) drawn by the machine in use. Fully extend the lead regardless of the distance between the power supply and the tool. Excess current (amps) and a coiled extension lead will both cause the cable to heat up and can result in fire.

**Concentrate and stay alert.** Distractions are likely to cause an accident. Never operate a power tool if you are under the influence of drugs (prescription or otherwise), including alcohol or if you are feeling tired. Being disorientated will result in an accident.

## 5. HEALTH & SAFETY INFORMATION

---

**Have this tool repaired by a qualified person.** This tool is designed to conform to the relevant international and local standards and as such should be maintained and repaired by someone qualified; using only original parts supplied by the manufacturer: This will ensure the tool remains safe to use.

### 5.2 ADDITIONAL SAFETY INSTRUCTIONS FOR SAFETY VALVES

**Information:** The safety valves are designed and constructed for use exclusively with compressed air, free from impurities. The materials used in construction are suitable for operating the valve at the rated pressure and temperatures. The Viton or NBR gasket conserves the resistance characteristics, even in prolonged use. The valve caulking impedes calibration modification; tampering with the valve and/or changing the constructor's calibration is forbidden.

**Installation:** Valve installation must be performed exclusively by technically prepared persons, who are responsible and in good health. Checking the integrity of the valve before installation is obligatory. Also, check that the valve pressure is no greater than the operating pressure of the tank or of the system to protect. Check that the discharge flow rate of the valve is greater than the quantity of the air to discharge. The safety valve must be positioned directly on the tank in a vertical position, in a dry, accessible place protected against the weather and far away from liquids or condensation. It must be positioned so as to have sufficient space all around for correct air discharge, without causing damage to persons and/or things. The valve rod must therefore be free in its movement when discharging. The connection between the valve and the part to be protected must be free from all kinds of choking and be as short as possible so as not to reduce the discharge flow rate of the valve itself. The connection passage area must be greater than the valve orifice area. During installation, screw on the valve with a torque spanner using the hexagonal part of the body. Apply a maximum torque of 30Nm, paying attention not to cause any deformation; using pincers, pliers, hammers or tools other than a hexagonal spanner is forbidden. Check the inlet hole and the shutter are not blocked by glue, teflon or similar materials that could bind the shutter or other functional components. If the valve is replaced, the compressor air contained in the system must be discharged first. We decline all responsibility for damage caused to persons and/or things due to failure to observe these instructions.

**Maintenance and inspection:** The valve must not be subject to knocks which may cause deformities. It is obligatory for qualified technicians to make sure that the safety valve functions correctly at least once a year. Valves equipped with a ring must be tested while pressurised to between 80-90% of the calibration value. Pull the ring and release immediately. During the test the valve must definitely open and discharge the air and re-close immediately when the ring is released. It is absolutely necessary to carry out this procedure with the utmost caution because this type of job can be dangerous if adequate safety measures are not taken; wear goggles, a head set and anything else necessary to protect against noise, jets of air, etc. which may be discharged from the valve.



## 5. HEALTH & SAFETY INFORMATION

---

### **5.3 ADDITIONAL SAFETY INSTRUCTIONS FOR PRESSURE VESSELS**

- This pressure tank is mainly intended for static use. It can only be charged with natural air within temperature and pressure limits as specified on the manufacturer's plate and declaration of conformity.
- Ensure that tank safety and control devices are efficient and flawless. When replaced, the tank should not be under pressure.
- Drain the condensation off the tank every day.
- Check for signs of inner corrosion at regular intervals. Tank walls should have a minimum thickness of 1.0 – 2.0mm.
- Any kind of welding to the tank is forbidden.
- The user shall comply with laws on pressure vessel operation in force in the country in which the tank is operated.
- The construction is mainly effected for permanent load by internal pressure. Cyclic loads are not considered, only for a range of 10% PS.

### **5.4 CONNECTION TO THE POWER SUPPLY**

Make sure the power supply information on the machine's rating plate are compatible with the power supply you intend to connect it to.

This compressor comes supplied with a UK standard 3 pin plug fitted. It is designed for connection to a domestic power supply rated at 230V AC.

Because it is constructed mostly of metal parts, it is a Class 1 machine; meaning, it must have an earth connection in the power supply. This is to prevent electrocution in the event of a failure.

Apart from replacing the fuse in the plug, no other electrical work is recommended on this compressor.

---

*Blank page*

## 6. TECHNICAL DESCRIPTION

---

### 6.1 IDENTIFICATION

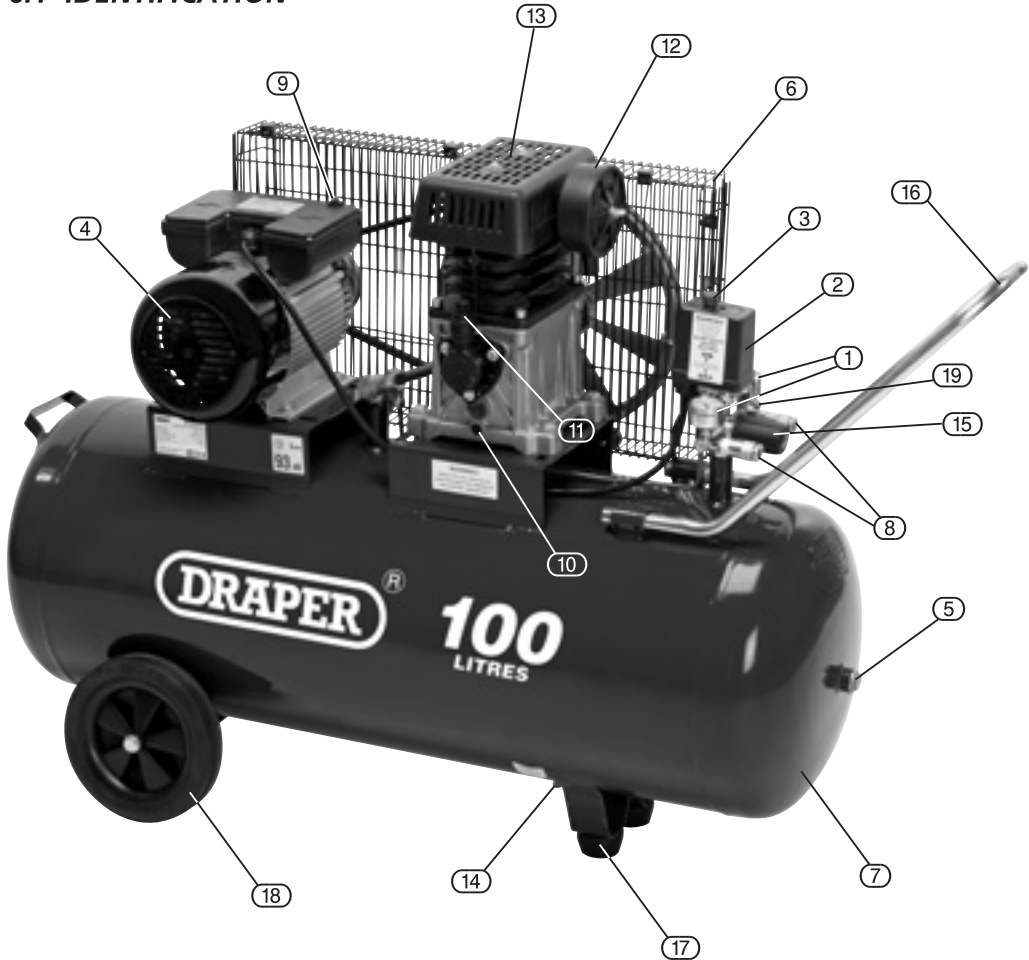

- ① Tank pressure gauge(s)
- ② Pressure switch unit
- ③ Pressure switch on/off button
- ④ Motor
- ⑤ Reservoir inspection plug
- ⑥ Pulley guard
- ⑦ Reservoir tank
- ⑧ Air line coupling(s)
- ⑨ Overload protection reset switch
- ⑩ Drain bung (oil)

- ⑪ Oil filler cap
- ⑫ Air filter
- ⑬ Pump unit
- ⑭ Drain bung (condensate)
- ⑮ Pressure regulator
- ⑯ Handle
- ⑰ Rubber feet
- ⑱ Wheels
- ⑲ Safety valve

## 7. UNPACKING & CHECKING

### 7.1 PACKAGING

Carefully remove the compressor from the packaging and examine it for any sign of damage that may have happened during shipping. Lay the contents out and check them against the parts shown below. If any part is damaged or missing; please contact the Draper Helpline (the telephone number appears on the Title page) and do not attempt to use the compressor.

The packaging material should be retained at least during the guarantee period: in case the machine needs to be returned for repair.

Warning! Some of the packaging materials used may be harmful to children. Do not leave any of these materials in the reach of children.

If any of the packaging is to be thrown away, make sure they are disposed of correctly; according to local regulations.

### 7.2 WHAT'S IN THE BOX?

When un-packing the new compressor, there may also be several ancillary parts not fitted or attached to it:

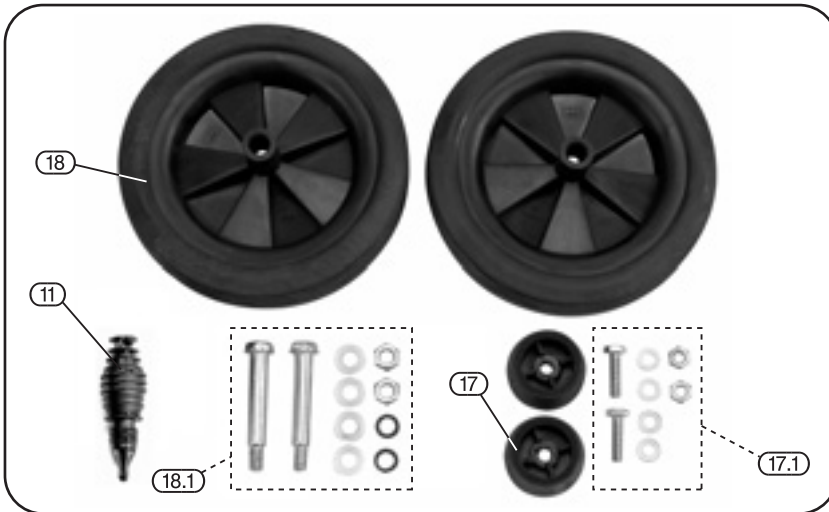

- (18) 2 x Wheels.
- (18.1) Wheel fittings.
- (17) 2 x Anti-vibration rubber feet.
- (17.1) Rubber foot fittings.
- (11) Oil filler cap.

## 8. ASSEMBLY & PREPARATION

**NOTE:** Remove the plug from the socket before carrying out adjustment, servicing or maintenance. It is extremely important to install the compressor in a clean, well ventilated area where the surrounding air temperature will not be more than 40°C. A minimum clearance of 500mm between the compressor and a wall is required.

### 8.1 FITTING THE WHEELS – FIG.1

Pass the bolt (18.2) through the wheel (18) and then place on the first washer (18.4), then the spacer (18.3). Fit the wheel through the wheel bracket on the underside of the compressor's frame then fit the second washer before finally securing with the nut (18.5).

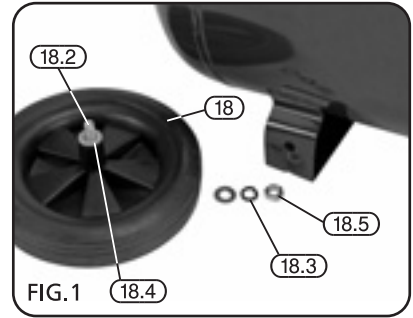

### 8.2 FITTING THE RUBBER ANTI-VIBRATION FOOT – FIG.2

Pass the bolt (17.2) through the rubber foot (17) and place on the first washer (17.3). Pass the bolt through the foot bracket (17.4) on the bottom of the tank then fit the second washer before finally securing with the nut (17.5).

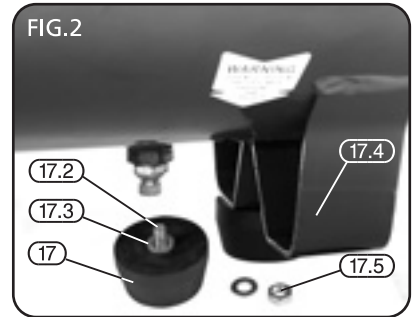

### 8.3 ASSEMBLING THE HANDLE – FIG.3

To assemble the handle (16) to the compressor, loosen the screws in each of the handle fixing tubes using a hex. key (not supplied).

Insert the two ends of the handle into the fixing tube and secure in place by tightening the screws with the hex. key.

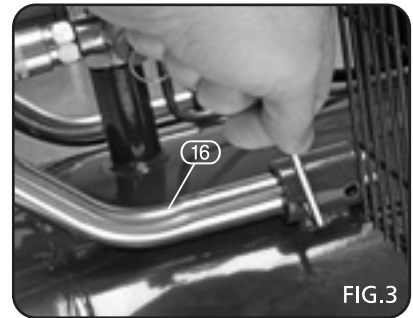

### 8.4 FITTING THE AIR FILTER – FIG.4

To fit the air filter module (12), slot the module into the inlet located on the pump unit housing and fasten in place with the securing nut (12.1).

The air filter element is located inside the module and can be accessed for replacement by removing the cover. – (for further information on air filter maintenance, see section 11.3 monthly operations, on page 17).

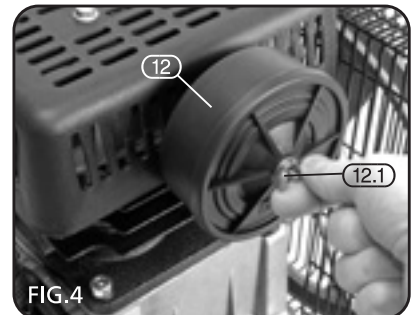

## 8. ASSEMBLY & PREPARATION

---

### 8.5 FILLING WITH OIL – FIGS.5 - 6

**WARNING!** This air compressor must be filled with oil before first use.

Remove the oil filler cap (11) located on the top of the crank case of the compressor housing.

Fill the crank case with the recommended oil until the oil level seen in the oil level glass (11.1) is up to the mid point of the red circle.

Replace the oil filling cap ensuring the cap is fully fitted and firmly in position.

Never use an alternative oil filling cap, as this is also the crank case breather.

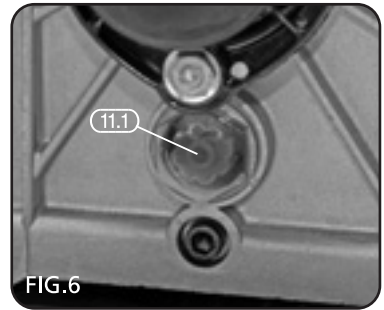
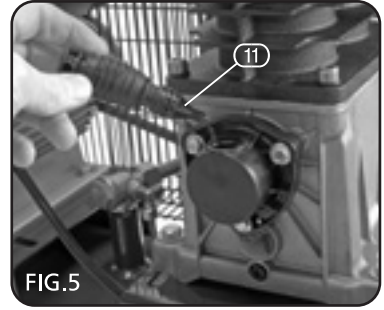

### 8.6 FINAL CHECKS PRIOR TO USE

In addition to pneumatic air tools, your compressor may be connected to several accessories suitable for blowing, washing and spraying. For technical specifications and detailed instructions, please refer to the instructions provided for the individual accessory.

When the installation procedure is complete, the compressor is ready for use. Make sure the pressure switch button (3) is positioned "OFF".

# 9. OPERATING THE COMPRESSOR

## 9.1 BASIC COMPRESSOR OPERATION – FIGS. 7-9

- Ensure that the location for the compressor is clean, dry and well ventilated.
- Ensure the crank case has been filled with oil and is at the correct level. (for more information see page 12, section 8.5 – filling with oil).
- Check the rating label on the compressor.
- Connect the compressor power cable to a suitable electrical output point.

**NOTE:** Use of an extension cord is **NOT** recommended.

- The compressor is switched on by lifting the on/off button (3) on top of the pressure unit (Fig. 7).
- The compressor is switched off by pressing the same on/off button down.

**NOTE:** This compressor is fitted with 2 pressure gauges and 2 outlets. Pressure gauge (1.1) displays the tank pressure and pressure gauge (1) displays the outlet pressure on the left connector only and is controlled by the regulator (15). The right connector is at tank pressure.

- Connect the air line to the compressor by pulling back the collar (8.1) on the air outlet quick coupling (8) and inserting the corresponding air coupling fitted on the air line. Release the collar so it slides back in place to secure the air coupling.
- Turn the air regulator (15) clockwise to its lowest setting and turn on the compressor by lifting the pressure switch on/off button (3) upwards.
- To obtain the correct output reading on the regulated output gauge (1), the air must be flowing through the outlet. The regulating valve should be adjusted and the gauge read with the outlet valve open and the air being discharged from the regulated outlet.
- To increase the pressure, rotate the pressure regulator (15) clockwise. To decrease the pressure, rotate the pressure regulator anti-clockwise.

**NOTE:** If you do not allow the air to discharge while you are setting the regulator, the pressure as indicated on the regulated outlet gauge will be incorrect. This gauge ONLY indicates the correct pressure while air is being discharged from the outlet.

The operation is automatically controlled by the pressure switch unit (2) which stops the motor when the max. pressure allowed is achieved, and starts it again when the pressure goes below the minimum threshold (about 2 bar less than the max. pressure).

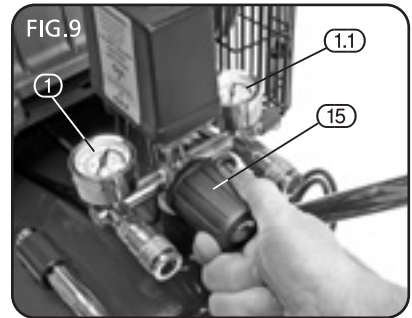
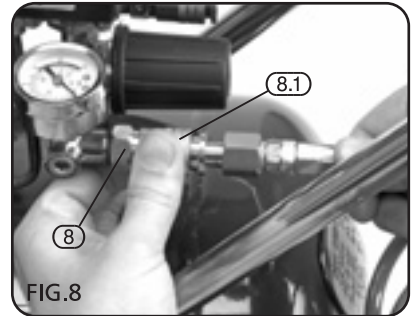
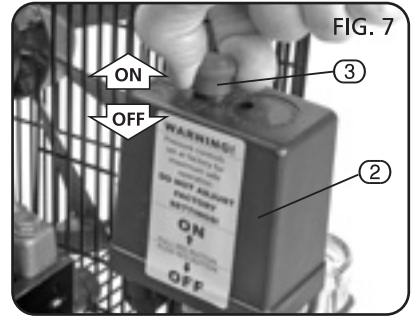

## 9. OPERATING THE COMPRESSOR

- On completion of the task, i.e. when you have finished using the compressor, or when you are leaving the compressor unattended, turn off the compressor in the following way:
  - Press down the on/off button (3).
  - Wait for the pressurised air to bleed from the tank from the release valve.
  - Switch off the electrical power supply and remove the plug from the outlet point.

**WARNING:** Never unplug the compressor or switch off the main switch to stop the compressor. Always position the pressure switch to the off position.

### 9.2 SAFETY VALVE – FIG. 10

**WARNING:** DO NOT REMOVE OR ATTEMPT TO ADJUST THE SAFETY VALVE!

This valve (19) should be checked under pressure occasionally by pulling the ring (19.1) by hand. If air leaks after the ring has been released, or valve is stuck, it MUST be replaced.

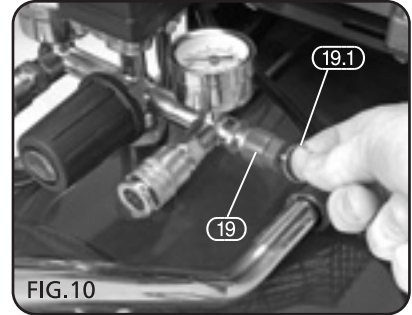

### 9.3 ADJUSTING THE PRESSURE SWITCH – FIG. 11

**NOTE:** This is the only operation where it is acceptable to switch the compressor off without using the pressure switch.

To decrease the pressure switch, run the compressor up to the desired capacity for the pressure switch to be set. At this point, turn the mains power off and do not operate the red button on the pressure switch as this will release the pressure. Disconnect the machine from the power source before loosening screw (2.1) to remove the black cover. With this removed, the adjustment bolt (2.2) will be visible. Adjust this anti-clockwise gently until the switch is heard to release the pressure. Release the cover and tighten the screw. The switch will now be set to the new pressure. To increase the pressure switch, remove the switch cover (having disconnected the machine from the power supply) and turn the adjustment bolt clockwise 3 turns and replace the switch cover.

Run the compressor up to the desired capacity for the pressure switch to be set (do not let the compressor run past its maximum pressure). At this point turn the mains power off and disconnect from the supply. Remove the black cover and adjust bolt anti-clockwise gently until the switch is heard to release the pressure. Replace the cover and tighten the screw. The switch will now be set to the new pressure.

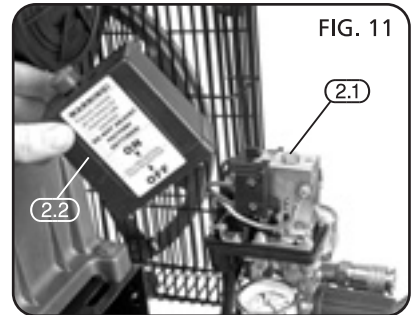



## 9. OPERATING THE COMPRESSOR

### 9.4 OVERLOAD CUT-OUT - FIG. 12

The compressor is equipped with an overload cut-out (9) which operates as a safety device to protect the motor. The device will activate in case of motor overload or overheating due to operation troubles. In this case, the safety device will automatically activate, disconnecting the compressor and avoiding possible motor damages. To restart the compressor, proceed as follows.

- Allow three minutes.
  - Position the pressure switch to "0" OFF.
  - Manually reset the thermal cut-out.
  - Position the pressure switch to "1" ON.



If you restart the compressor and the overload cut-out releases again, turn the main switch to the OFF position, unplug the equipment and contact the Authorised Service Centre.

NOTE: After reconnection is complete, ensure that the tap is opened again. It is essential to connect an air line filter separator and lubricator to ensure a good, clean air supply is provided for the tool.

(NOTE: If the intended tool for use is a spray gun, use only a filter separator as lubrication will cause contamination of the material being sprayed).

Draper Stock No.43402 - Air filter, Regulator & Lubricator.

Draper Stock No.43394 - Air filter & Regulator.

To ensure an optimum air supply, please refer and carry out the following procedures as recommended.

### 9.5 MOISTURE IN COMPRESSED AIR

Moisture in compressed air will form into droplets as it comes from an air compressor pump. When humidity is high or when a compressor is in continuous use for an extended period of time, this moisture will collect in the tank. When using a paint spray gun or sandblast gun, this water will be carried from the tank through the hose, and out of the gun as droplets mixed with the spray material.

**IMPORTANT:** This condensation will cause water spots in a paint job, especially when spraying other than water based paints. If sandblasting, it will cause the sand to case and clog the gun rendering it ineffective. A filter in the air line, located as near to the gun as possible, will help eliminate this moisture.

### 9.6 STORAGE

- When not in use, store hose and compressor in a cool dry place.
- Pull the ring on the safety valve to ensure all pressurised air is released from the tank and open the drain bung to empty the tank of any accumulated moisture.
- Disconnect hose and hang open ends down to allow any moisture to drain.

## 10. TROUBLESHOOTING

FAULT	POSSIBLE CAUSE	REMEDY
<p>Motor won't run.</p> <p>Motor running too slow or getting too hot.</p>	<ol style="list-style-type: none"> <li>1. No electrical power.</li> <li>2. Power wiring too thin or too long.</li> <li>3. Fault in pressure switch.</li> <li>4. Fault in motor.</li> <li>5. Sticking of main compressor.</li> </ol>	<ol style="list-style-type: none"> <li>1. Check the power supply.</li> <li>2. Replace the wire.</li> <li>3. Repair or replace.</li> <li>4. Repair or replace.</li> <li>5. Check and repair.</li> </ol>
<p>Sticking of main compressor.</p>	<ol style="list-style-type: none"> <li>1. Moving parts damaged due to insufficient oil lubrication.</li> <li>2. Moving parts damaged, or stuck by foreign body.</li> </ol>	<p>Check crankshaft, bearing connecting rod, piston, piston ring, etc., and replace if necessary.</p>
<p>Excessive compressor motor shaking or abnormal noise.</p>	<ol style="list-style-type: none"> <li>1. Connecting part loosened.</li> <li>2. Foreign body in main compressor.</li> <li>3. Piston knocking valve seat.</li> <li>4. Moving parts seriously worn.</li> </ol>	<ol style="list-style-type: none"> <li>1. Check and retighten.</li> <li>2. Check for object, remove and clean.</li> <li>3. Replace with thick paper gasket.</li> <li>4. Repair or replace.</li> </ol>
<p>Pressure insufficient or discharge capacity decreased.</p>	<ol style="list-style-type: none"> <li>1. Motor running too slow.</li> <li>2. Air filter choked up.</li> <li>3. Leakage of safety valve.</li> <li>4. Leakage of discharge pipe.</li> <li>5. Sealing gasket damaged.</li> <li>6. Valve plate damaged, carbon buildup or stuck.</li> <li>7. Piston ring and cylinder worn or damaged.</li> </ol>	<ol style="list-style-type: none"> <li>1. Check and remedy.</li> <li>2. Clean or replace the cartridge.</li> <li>3. Check and adjust.</li> <li>4. Check and repair.</li> <li>5. Check and replace.</li> <li>6. Replace and clean.</li> <li>7. Repair or replace.</li> </ol>
<p>Excessive oil consumption.</p>	<ol style="list-style-type: none"> <li>1. Oil level too high.</li> <li>2. Breather pipe blockage.</li> <li>3. Piston ring and cylinder worn or damaged.</li> </ol>	<ol style="list-style-type: none"> <li>1. Keep the level within the set range.</li> <li>2. Check and clean.</li> <li>3. Repair or replace.</li> </ol>

# 11. MAINTENANCE

Some of the operations listed in this section will require the compressor to be returned to an authorised service agent.

Before carrying out any service or routine operation to your compressor, ensure the power has been cut off and all pressure has been released from the tank, so as to prevent any sudden unexpected restart. After any maintenance operation, make sure all components have been fitted correctly.

In order to keep your compressor in a good working condition, we recommend you to perform periodical servicing operations. Before performing any maintenance operation, switch off the compressor and ensure all air in the tank is released.

## 11.1 OPERATIONS TO BE CARRIED OUT AFTER THE FIRST 50 WORKING HOURS

Check that all screws and bolts are properly tight, paying special care to the head and crank case. Replace the lubricant with one of the recommended oils listed in the table (see page 18). Never mix different oils together. Do not use non-detergent oils or low quality oils as they have very poor lubricating properties. Do not dispose of the oil in the environment. Always contact your local authority for disposal.

## 11.2 WEEKLY OPERATIONS - FIGS. 13 - 14

Check the oil level and if necessary top up (Fig.13). Do not exceed the mark corresponding to the max. level. Make sure the oil does not drop below the minimum so as to avoid any damage or seizure. Drain condensation, while the tank is pressurised, by opening the valve (14) located under the tank (Fig.14). Open the valve by turning it anti-clockwise with a container under the valve. Keep the compressor in a position to allow all condensation to flow out completely. The tank must have pressure inside to force out any water present.

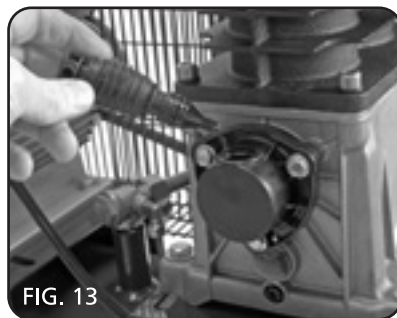

FIG. 13

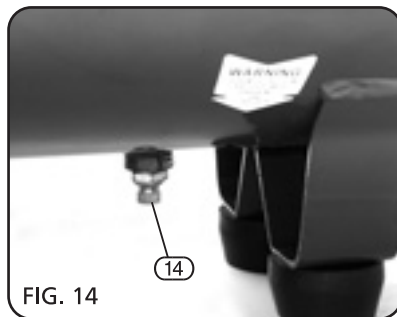

FIG. 14

## 11.3 MONTHLY OPERATIONS (OR MORE FREQUENTLY IF THE COMPRESSOR OPERATES IN VERY DUSTY CONDITIONS) – FIG.15

Remove the cover on the air filter module (12) to access and replace the interior element (12.2). Do not operate the compressor without the air filter fitted, as foreign bodies or dust could seriously damage the inside components.

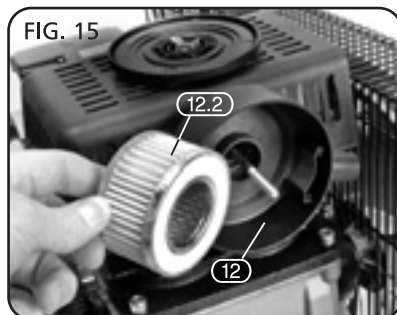

FIG. 15

# 11. MAINTENANCE

## 11.4 OPERATIONS TO BE CARRIED OUT EVERY 6 MONTHS – FIGS 16 - 18

Pull out the oil filler cap (11) and loosen the screw (11.1) to change the oil. Collect the oil into a suitable container.

You should perform this operation when the compressor is hot so as to follow the oil to drain rapidly and completely. Tighten the screw (11.1) in its housing and pour in the new oil up to the max. level and no higher.

It is advisable to clean all the finned parts of your compressor, so as to keep the cooling system efficient and to ensure a long work life to your machine. Check belt tension. Hang a weight of about 3kg at the midpoint of the belt. The belt should flex about 10mm (Fig.17).

If necessary, tension up the belt taking care not to disturb the pulley-to-flywheel alignment. (Fig.18).

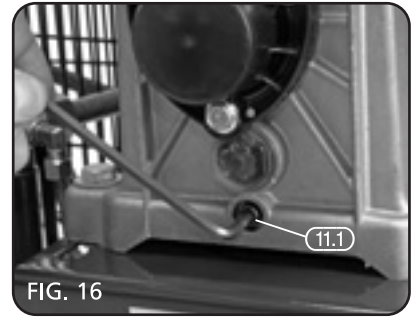

FIG. 16

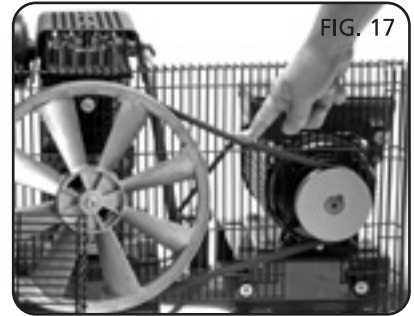

FIG. 17

## 11.5 OPERATIONS TO BE CARRIED OUT EVERY 2 YEARS:

Check the non-return valve and if necessary replace the seal. Check intake and delivery valves in valve plates.

## 11.6 RECOMMENDED OILS:

Recommended oils with ISO grade 100 for compressors, in accordance with DIN 51506 Standard (suitable for room temperature ranging from +6°C and +25°C).

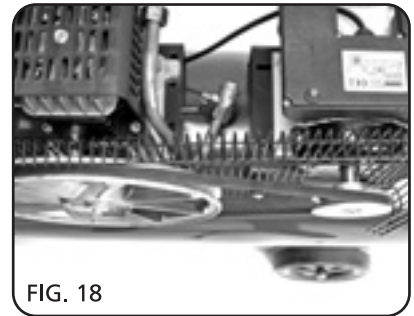

FIG. 18

AGIP	DICREA
BP	ENERGOL
CASTROL	AIRCOL
MOBIL	RARUS
SHELL	CORENA

Use oils with an ISO grade 46/68 for a room temperature ranging from 0°C to +5°C.

Use oils with an ISO grade 150 for a room temperature ranging from +26°C to +45°C.

## 12. EXPLANATION OF SYMBOLS

---

### 12.1 EXPLANATION OF SYMBOLS



Warning!  
Wear dust mask.



Warning!  
Read the instruction manual



Warning!  
Wear goggles.



Warning!  
Wear ear defenders.



WEEE  
Do not dispose of Waste Electrical  
& Electronic Equipment in with  
domestic rubbish



Class II construction.  
(Double insulated).



For indoor use.  
Do not expose to rain.

# 13. DISPOSAL

---

## 13.1 DISPOSAL

At the end of the machine's working life, or when it can no longer be repaired, ensure that it is disposed of according to national regulations.

– Contact your local authority for details of collection schemes in your area.

In all circumstances:

- Do not dispose of power tools with domestic waste.
- Do not incinerate.
- Do not abandon in the environment.
- Do not dispose of WEEE\* as unsorted municipal waste.



\* Waste Electrical & Electronic Equipment.

# 14. GLOSSARY

---

## 14.1 GLOSSARY

### *Alphabetical list of words relating to this manual*

<b>Check valve</b>	A one-way valve that allows air to enter the tank but prevents air in the tank from flowing back into the compressor pump.
<b>Regulator</b>	The regulator controls the amount of air pressure released at the hose outlet.
<b>Safety valve</b>	The valve automatically releases air if the tank pressure exceeds maximum pressure.







- **DRAPER TOOLS LIMITED,**  
Hursley Road, Chandler's Ford,  
Eastleigh, Hampshire. SO53 1YF. U.K.
- **Helpline:** (023) 8049 4344
- **Sales Desk:** (023) 8049 4333
- **Website:** [www.drapertools.com](http://www.drapertools.com)
- **E-mail:** [sales@drapertools.com](mailto:sales@drapertools.com)
- **Sales Fax:** (023) 8049 4209
- **General Enquiries:** (023) 8026 6355
- **Service/Warranty Repair Agent**  
For aftersales servicing or warranty repairs, please contact the Draper Tools Helpline for details of an agent in your local area.

YOUR DRAPER STOCKIST