

DRAPER[®]

PETROL
**BLOWER/
VAC**

32301

IMPORTANT: PLEASE READ THESE INSTRUCTIONS CAREFULLY TO ENSURE THE SAFE AND EFFECTIVE USE OF THIS PRODUCT.



INSTRUCTIONS

These instructions accompanying the product are the original instructions. This document is part of the product, keep it for the life of the product passing it on to any subsequent holder of the product. Read all these instructions before assembling, operating or maintaining this product.

This manual has been compiled by Draper Tools describing the purpose for which the product has been designed, and contains all the necessary information to ensure its correct and safe use. By following all the general safety instructions contained in this manual, it will ensure both product and operator safety, together with longer life of the product itself.

All photographs and drawings in this manual are supplied by Draper Tools to help illustrate the operation of the product.

Whilst every effort has been made to ensure the accuracy of information contained in this manual, the Draper Tools policy of continuous improvement determines the right to make modifications without prior warning.

1. TITLE PAGE

1.1 INTRODUCTION:

USER MANUAL FOR: Petrol Blower Vac

Stock No: 32301

Part No: BVP26

1.2 REVISIONS:

Date first published May 2017.

As our user manuals are continually updated, users should make sure that they use the very latest version.

Downloads are available from: <http://www.drapertools.com/manuals>

Draper Tools Limited
Hursley Road
Chandler's Ford
Eastleigh
Hampshire
SO53 1YF
UK

Website: drapertools.com

Product Helpline: +44 (0) 23 8049 4344

General Fax: +44 (0) 23 8026 0784

1.3 UNDERSTANDING THIS MANUALS SAFETY CONTENT:

WARNING! – Information that draws attention to the risk of injury or death.

CAUTION! – Information that draws attention to the risk of damage to the product or surroundings.

1.4 COPYRIGHT © NOTICE:

Copyright © Draper Tools Limited.

Permission is granted to reproduce this publication for personal and educational use only. Commercial copying, redistribution, hiring or lending is prohibited.

No part of this publication may be stored in a retrieval system or transmitted in any other form or means without written permission from Draper Tools Limited.

In all cases this copyright notice must remain intact.

2. CONTENTS

1. TITLE PAGE

1.1 INTRODUCTION.....	2
1.2 REVISION HISTORY	2
1.3 UNDERSTANDING THIS MANUAL	2
1.4 COPYRIGHT NOTICE	2

2. CONTENTS

2.1 CONTENTS	3
--------------------	---

3. GUARANTEE

3.1 GUARANTEE	4
---------------------	---

4. INTRODUCTION

4.1 SCOPE.....	5
4.2 SPECIFICATION	5
4.3 HANDLING AND STORAGE	5

5. HEALTH AND SAFETY INFORMATION

5.1 SPECIFIC SAFETY INSTRUCTION FOR PETROL BLOWER/VAC'S	6
– Service	6
5.2 HEALTH AND SAFETY INFORMATION CONCERNING THE USE OF FUELS	6

6. TECHNICAL DESCRIPTION

6.1 IDENTIFICATION	8
--------------------------	---

7. UNPACKING AND CHECKING

7.1 PACKAGING	9
7.2 WHAT'S IN THE BOX.....	9

8. ASSEMBLING THE PETROL BLOWER/VAC

8.1 ASSEMBLING THE BLOWER TUBES	10
8.2 ASSEMBLING THE VACUUM TUBES	11
8.3 ATTACHING THE COLLECTION BAG	12
8.4 ATTACHING THE CARRYING STRAP	12

9. OPERATING INSTRUCTIONS

9.1 FUELLING	13
9.2 COLD STARTING THE ENGINE.....	14
9.3 WARM STARTING THE ENGINE	15
9.4 STOPPING THE ENGINE	16
9.5 ADJUSTING THE ENGINE IDLE SPEED	16
9.6 USING THE BLOWER/VAC	17
– Blower Operation	17
– Vacuum Operation	17

10. MAINTENANCE AND TROUBLESHOOTING

10.1 CLEANING THE AIR FILTER	18
10.2 SPARK PLUG MAINTENANCE	18
10.3 CLEANING THE FUEL FILTER.....	19
10.4 TROUBLESHOOTING GUIDE	19
10.5 CLEANING AND MAINTENANCE OVERVIEW.....	20
10.6 STORING THE MACHINE FOR AN EXTENDED PERIOD OF TIME	20

11. EXPLANATION OF SYMBOLS

11.1 EXPLANATION OF SYMBOLS	21
-----------------------------------	----

12. DISPOSAL

12.1 DISPOSAL	22
---------------------	----

DECLARATION OF CONFORMITY ENCLOSED

3. GUARANTEE

3.1 GUARANTEE

Draper tools have been carefully tested and inspected before shipment and are guaranteed to be free from defective materials and workmanship.

Should the tool develop a fault, please return the complete tool to your nearest distributor or contact:

Draper Tools Limited, Chandler's Ford, Eastleigh, Hampshire, SO53 1YF. England.

Telephone Sales Desk: (023) 8049 4333 or:

Product Helpline (023) 8049 4344.

A proof of purchase must be provided with the tool.

If upon inspection it is found that the fault occurring is due to defective materials or workmanship, repairs will be carried out free of charge. This guarantee period covering parts/labour is 12 months from the date of purchase except where tools are hired out when the guarantee period is 90 days from the date of purchase. The guarantee is extended to 12 months for parts only. This guarantee does not apply to normal wear and tear, nor does it cover any damage caused by misuse, careless or unsafe handling, alterations, accidents, or repairs attempted or made by any personnel other than the authorised Draper warranty repair agent.

Note: If the tool is found not to be within the terms of warranty, repairs and carriage charges will be quoted and made accordingly.

This guarantee applies in lieu of any other guarantee expressed or implied and variations of its terms are not authorised.

Your Draper guarantee is not effective unless you can produce upon request a dated receipt or invoice to verify your proof of purchase within the guarantee period.

Please note that this guarantee is an additional benefit and does not affect your statutory rights.

Draper Tools Limited.

4. INTRODUCTION

4.1 SCOPE

This product is designed for blowing fallen leaves and other loose green matter prior to collection. This product is designed for use in the domestic environment only.

4.2 SPECIFICATION

Stock No:	32301
Part No:	BVP26
Engine displacement.....	25.4cc
Maximum revolutions per min. (no load)	7,000min ⁻¹
Maximum revolutions per min. at idle (no load).....	3,200min ⁻¹
Fuel tank capacity	0.65L
Fuel mixture.....	30:1 ^{††}
Carburettor	Diaphragm type with primer pump
Spark plug	L7T
Air flow:	
Maximum air speed (blowing).....	75m/s (270km/h)
Maximum air speed (vacuuming).....	6.3m ³ /min
Sound pressure level.....	86dB(A)
Sound power level.....	103dB(A)
Single value noise level (LWA) [†]	103dB(A)
Vibration level.....	5.5±1.5m/s ²
Dimensions (assembled) (L × W × H)	1210 × 520 × 360mm
Weight (dry, with vacuum tubes)	5.4kg

[†]A-weighted sound pressure level in accordance to 2000/14/EC.

^{††}Use semi-synthetic 2 stroke oil.

4.3 HANDLING AND STORAGE

Care must still be taken when handling and lifting. Dropping this machine will have an effect on the accuracy and may also result in personal injury. This machine is not a toy and must be respected.

The environment will have a negative result on its operation if you are not careful. If the air is damp, components will rust. If the machine is unprotected from dust and debris; components will become clogged: And if not cleaned and maintained correctly or regularly the machine will not perform at its best.

5. HEALTH AND SAFETY INFORMATION

5.1 SPECIFIC SAFETY INSTRUCTIONS FOR PETROL BLOWER/VAC'S

Warning! For your safety, please read and understand these instructions before assembling, operating or maintaining this machine.

- Never attempt to modify or operate a modified machine. Fully assemble this machine, including all relevant guards, before operating.
- Do not operate this machine without being completely familiar with the safety features and how to operate them.
- Never operate this machine if the stop switch is faulty or not functioning.
- Never operate this machine while tired, ill or under the influence of drugs.

Danger! Keep out of the reach of children.

- Fully read and understand before attempting to assemble, operate or maintain the machine.
- Never allow people unfamiliar with these instructions to operate this machine. Local regulations may restrict the age of the operator.
- Prior to each use, inspect the machine for signs of damage. Make sure the safety features are present and functioning and that all visible nuts, bolts and screws remain tight. Vibration from normal use can cause them to loosen over time.
- Never operate this machine with defective or missing guards.

Warning! Use of this product can pose a danger to wildlife. Before attempting to use this machine, check the area, particularly long grass and under bushes for signs of life: if necessary relocate.

Note: Not all animals will be deterred by the noise of the product alone.

- Do not point the blower/vac nozzle in the direction of people or pets.
- Check the attachment is correctly fitted to the machine before attempting to start the engine.

Caution! As the user you are responsible for any injury to people or damage to property.

Warning! During use the engine gets very hot. Do not touch it, especially the exhaust.

- Always be aware of your surroundings, staying alert for possible hazards that you may not hear over the noise of the engine.
- Always hold the blower/vac in your right hand, refer to the operating instructions in the manual.
- To reduce the risk of hearing loss associated with sound level, hearing protection is required.
- Wear suitable gloves to help reduce vibration fatigue.

Service

Have your power tool serviced by a qualified repair person using only identical replacement parts. This will ensure that the safety of the power tool is maintained.

5.2 HEALTH AND SAFETY INFORMATION CONCERNING THE USE OF FUELS

Fuels are inflammable and explosive. Reduce the risk of explosion and fire by:

- Turning off and cooling the motor down before filling the tank with fuel.
- Refraining from smoking and starting open fires when handling fuels.
- Storing and mixing fuels in approved and correspondingly labelled canisters.

5. HEALTH AND SAFETY INFORMATION

- Storing fuels in closed containers. Keeping in mind that fuels may evaporate at room temperature and collect on the floor of closed rooms (risk of explosion).
- Start the device at least nine metres away from any stored fuels or flammable liquids.
Fuels are toxic, they contain substances that have an immediate toxic effect and may cause permanent damage to your health. Take all precautionary measures to prevent your body from absorbing any of these substances:
- Tank and siphon fuels only outdoors or in well-ventilated rooms.
- Do not inhale fuel fumes.
- Avoid contact with eyes and skin.
- Wear gloves when transferring fuel.
- When fuel has come into contact with your clothes, change them immediately. Clean your clothes before putting them back on.
- Store fuels out of the reach of children.

When handled inappropriately, fuels may cause damage to the environment:

- Transfer fuel carefully. Fuel must never trickle into the ground or the sewage system.
- Dispose of any remaining fuel in an appropriate manner. Never dispose of fuel with regular household waste.
- Fuels may be stored only for a limited time. Purchase only such quantities that can be used up within a few months.

6. TECHNICAL DESCRIPTION

6.1 IDENTIFICATION

- ① Petrol motor unit.
- ② Carry handle.
- ③ Throttle trigger.
- ④ ON/OFF/Ignition switch.
- ⑤ Blower nozzle.
- ⑥ Blower tube.
- ⑦ Vacuum air intake.
- ⑧ Carry strap.
- ⑨ Choke lever.
- ⑩ Recoil starter cord.
- ⑪ Air filter cover.
- ⑫ Fuel tank cap.
- ⑬ Fuel tank.
- ⑭ Side handle.
- ⑮ Exhaust.
- ⑯ Spark plug cap.
- ⑰ Fuel primer bulb.

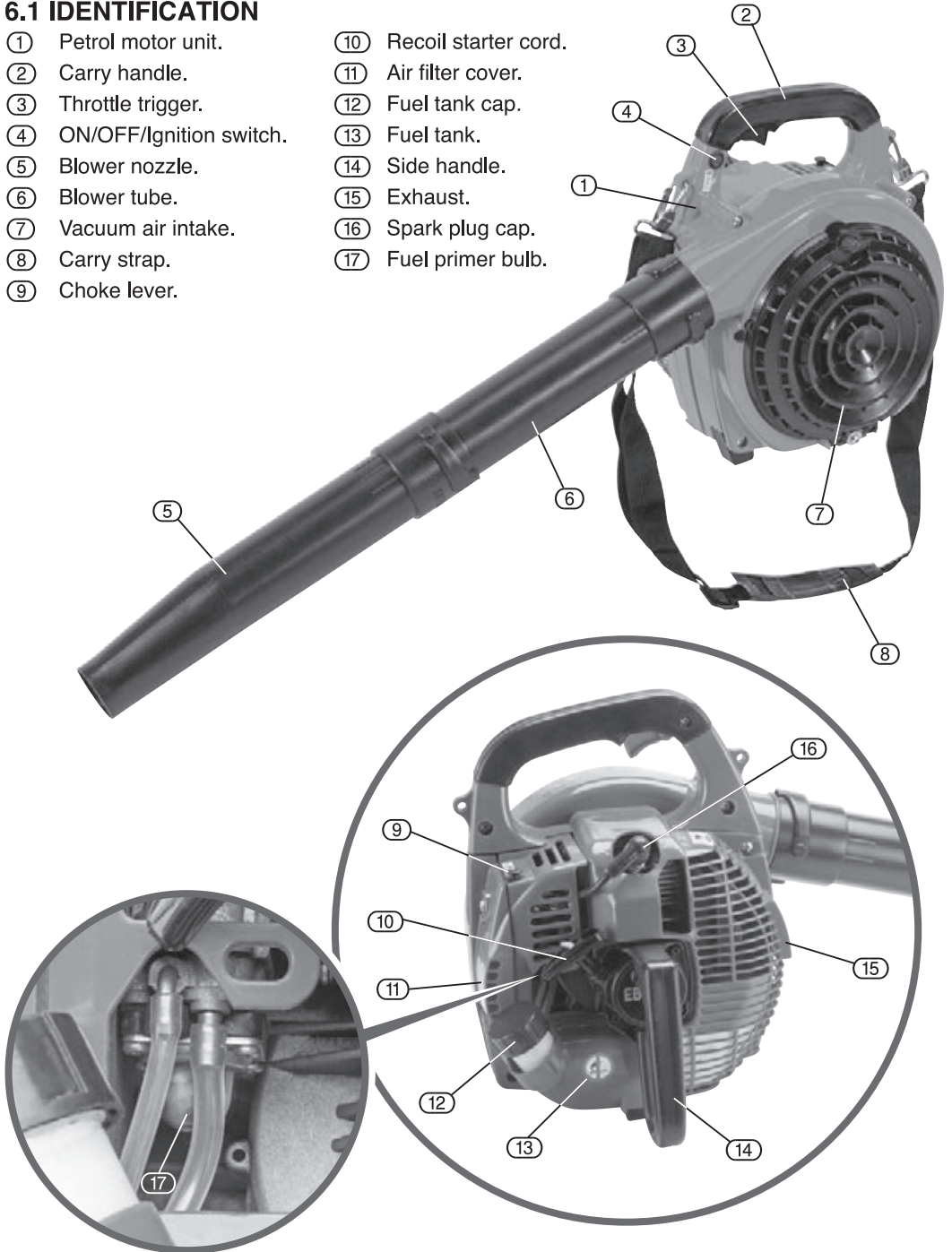

7. UNPACKING AND CHECKING

7.1 PACKAGING

Carefully remove the machine from the packaging and examine it for any sign of damage that may have happened during shipping. Lay the contents out and check them against the parts shown below. If any part is damaged or missing; please contact the Draper Helpline (the telephone number appears on the Title page) and do not attempt to use the machine.

The packaging material should be retained at least during the guarantee period: in case the machine needs to be returned for repair.

Warning! Some of the packaging materials used may be harmful to children. Do not leave any of these materials in the reach of children.

If any of the packaging is to be thrown away, make sure they are disposed of correctly; according to local regulations.

7.2 WHAT'S IN THE BOX?

As well as the blower vac, there are several parts not fitted or attached to it.



- ① Petrol motor unit.
- ⑤ Blower nozzle.
- ⑥ Blower tube.
- ⑧ Carry strap.
- ⑱ Collection bag intake tube.
- ⑲ Vacuum tube.
- ⑳ Vacuum nozzle.

- ⑳ Collection bag.
- ㉒ Fuel mixing bottle.
- ㉓ Screwdriver.
- ㉔ Large hex. key.
- ㉕ Small hex. key.
- ㉖ Box spanner.
- ㉗ M5 x 10 Screw x 3.

8. ASSEMBLING THE PETROL BLOWER/VAC

Important: This petrol blower vac can switch from blowing to suction functions. This is achieved by connecting the tubes to the correct mounting.

- For blowing function, the tube is fitted to the front outlet (see section 8.1: assembling the blower tubes).
- For vacuum function, the collection bag is fitted to the front outlet and the main tube is fitted to the mounting that is accessed by opening the vented side cover (see section 8.2: assembling the vacuum tubes).

8.1 ASSEMBLING THE BLOWER TUBES – FIGS. 1 – 3

Warning! Stop the engine and put the switch to STOP position before installing parts, making adjustments, cleaning or when not in use. Failure to do so could result in possible serious injury.

1 Slide the blower tube (6) over the discharge port (6.1) and locking lug (1.2).

2 Rotate the tube clockwise to lock in place.

3 Secure the blower tube in place using the supplied M5 x 10 screw (27) and the screwdriver end of the box spanner (26).

4 Slide the blower nozzle (5) on to the blower tube (6) and locking lug (6.1).

5 Rotate the nozzle clockwise to lock in place.

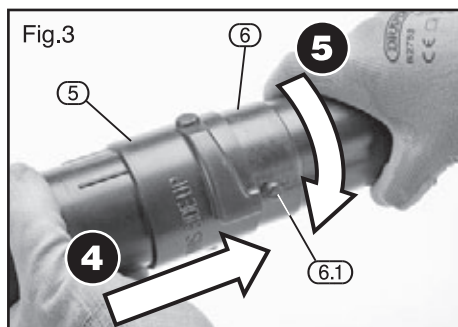
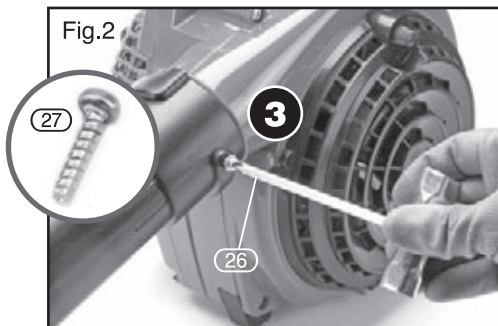
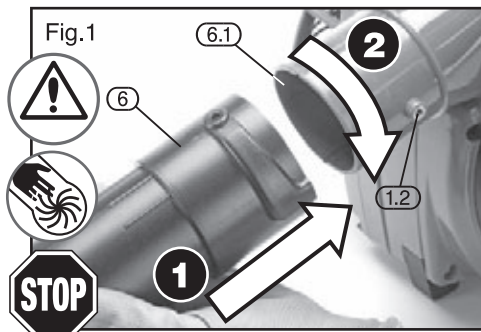

8. ASSEMBLING THE PETROL BLOWER/VAC

8.2 ASSEMBLING THE VACUUM TUBES – FIGS. 4 – 7

Warning! Stop the engine and put the switch to STOP position before installing parts, making adjustments, cleaning or when not in use. Failure to do so could result in possible serious injury.

1 Unscrew the retaining knob (7.1) on the vacuum intake cover (7.2).

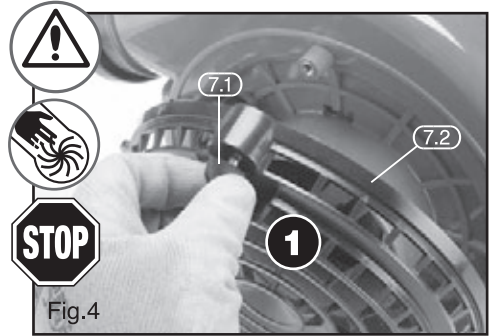

2 Slide the vacuum tube (19) over the air intake port (7.3) and locking lug (7.4).

3 Rotate the tube clockwise to lock in place.

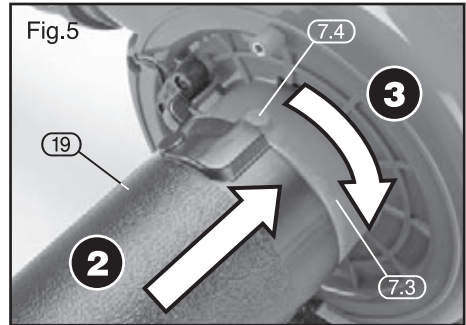

4 Slide the vacuum nozzle (20) over the vacuum tube (19) and locking lug.

5 Rotate the nozzle clockwise to lock in place.

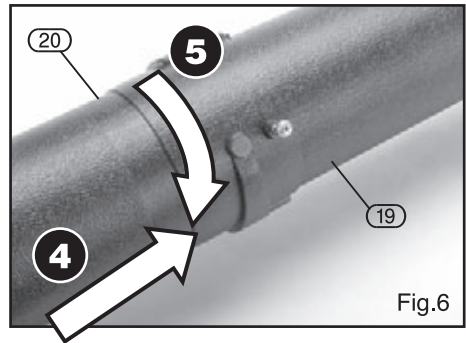

6 Secure the vacuum nozzle in place using the supplied M5 x 10 screw (27) and the screwdriver end of the box spanner (26).

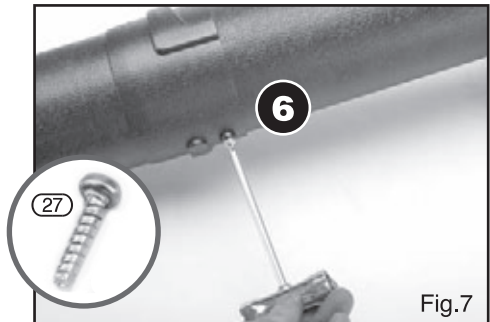

8. ASSEMBLING THE PETROL BLOWER/VAC

8.3 ATTACHING THE COLLECTION BAG – FIGS. 8 – 10

Warning! Stop the engine and put the switch to STOP position before installing parts, making adjustments, cleaning or when not in use. Failure to do so could result in possible serious injury.

- 1 Slide the collection bag intake tube (18) over the discharge port (6.1) and locking lug (1.2).
- 2 Rotate the tube clockwise to lock in place.
- 3 Secure the collection bag intake tube (18) in place using the supplied M5 x 10 screw (27) and the screwdriver end of the box spanner (26).
- 4 Secure the collection bag (21) to the collection bag intake tube (18) using the fastenings attached at the opening of the bag.

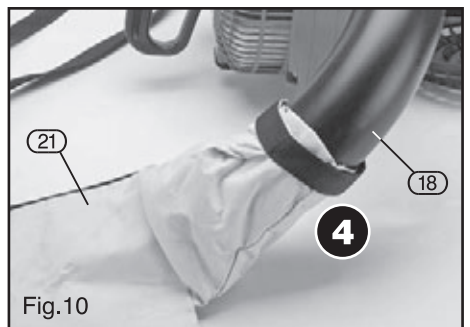
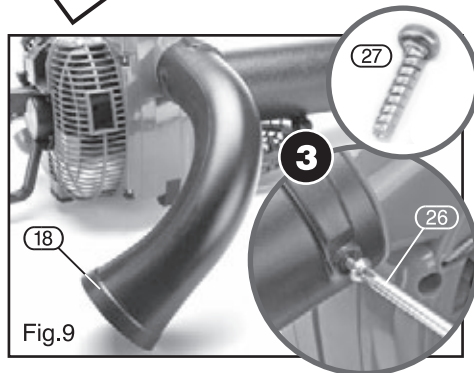
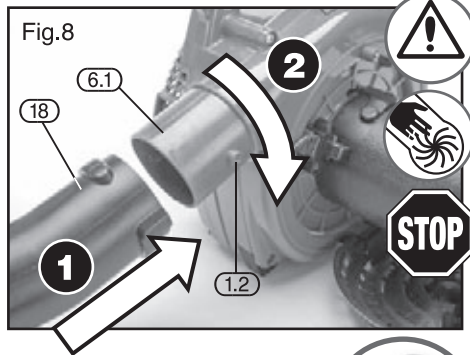

8.4 ATTACHING THE CARRYING STRAP – FIGS. 11 – 12

The petrol motor unit has 2 fastening points for the attachment of the carry strap (A & B).

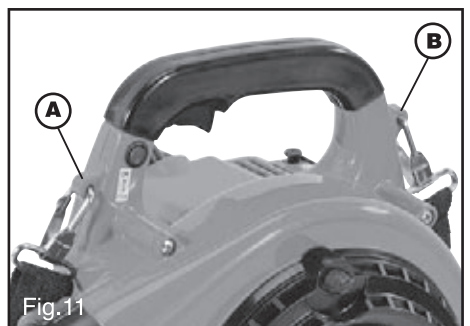

8. ASSEMBLING THE PETROL BLOWER/VAC

- 1 The carry strap is attached by threading each of the 2 sprung loaded buckles (8.1) through the holes in the 2 attachment points .



9.1 FUELLING – FIGS. 13 – 15

This petrol blower vac is equipped with a 2 stroke air cooled petrol engine.

This type of engine requires a mixture of fuel and oil to perform and function. Failure to use the correct oil, fuel or mixture ratio will cause permanent damage to the engine. Only use fresh, clean, good quality unleaded fuel mixed with a high quality 2 stroke oil. **Do not use any other types of oil e.g. engine oil as this will cause damage to the engine.**

For synthetic oil or semi-synthetic a mix ratio of 30:1 must be used. To mix a ratio of 30:1:

- 1 Add 166ml of 2 stroke oil into 5 litres of unleaded fuel (2%).

Attention: Always handle fuel with caution.

- 2 Pour the fuel/oil mixture into a specifically designed mixing receptacle before replacing the cap and shaking gently.
- 3 Remove the fuel tank cap (12) by turning it anti-clockwise. To prevent identification problems or accidents the fuel tank cap is stamped with the symbol .
- 4 With the aid of a funnel, if needed, pour the fuel/oil mixture into the fuel tank before replacing the cap firmly. Avoid spillage and do not over fill.

Note: Always mix and refuel in a well ventilated area away from sources of ignition.

Note: Store fuel for short periods only and avoid mixing more than is required. Store in a container specifically designed for petrochemical applications away from heat and direct sun light.

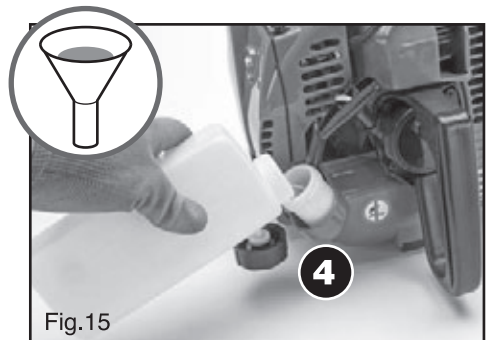
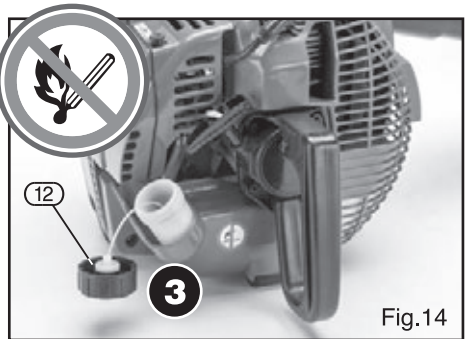
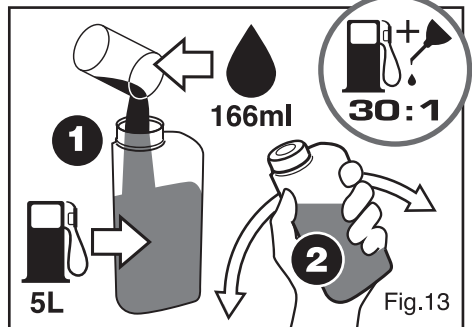

9. OPERATING INSTRUCTIONS



9.2 COLD STARTING THE ENGINE – FIGS. 16 – 20

Rest the blower/vac on a stable surface.

- 1 Press the ON/OFF/IGNITION switch (4) to the 'I' (ON) position.
- 2 Pull the choke lever (9) upwards to the  (closed) position.
- 3 Pump the primer (17) eight times until fuel flows in and out of the discharge line (17.1) with no air bubbles.
- 4 Standing behind the machine, firmly grip the front handle with your hand.
- 5 With your other hand grip the recoil starter cord (10). Pull the starter cord using short sharp movements.

Note: Do not use the full length of the recoil starter cord as this can cause breakage or premature failure. Do not release the starter cord to recoil on its own. Damage will occur to the mechanism.

- 6 Once the engine tries to fire, push the choke lever (9) downwards to the  (open) position.

Note: If there is a strong smell of fuel this indicates that the engine may be flooded. Wait a few minutes before attempting to restart the machine as if the engine were warm i.e. no choke.

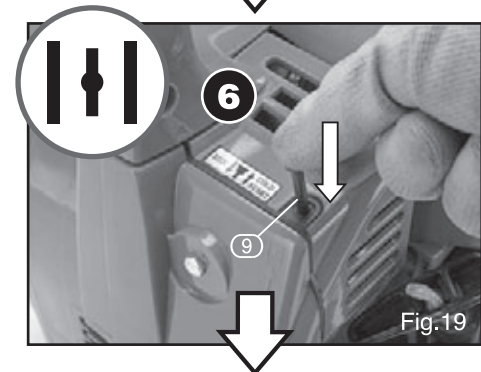
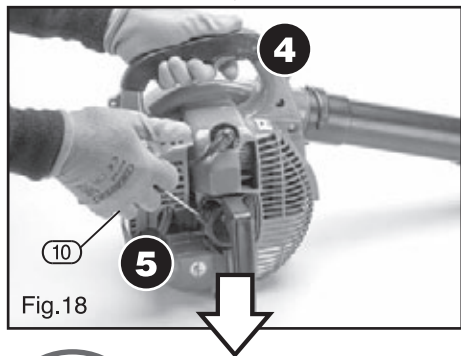
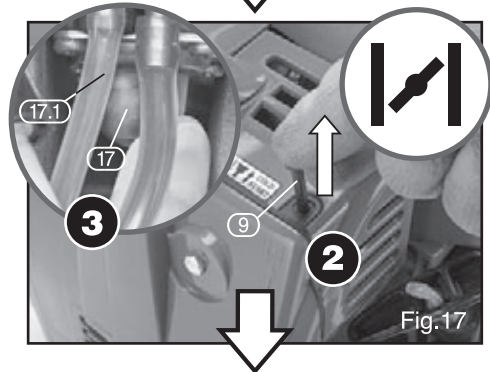
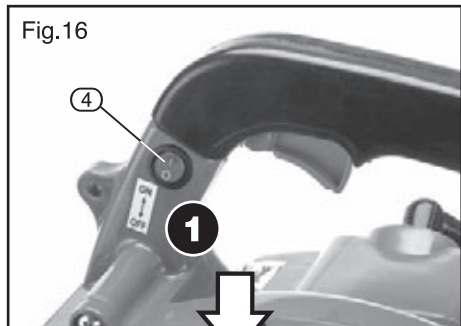

9. OPERATING INSTRUCTIONS

- 7 Once the motor has started, allow the motor to warm up for a few minutes before commencing operation.

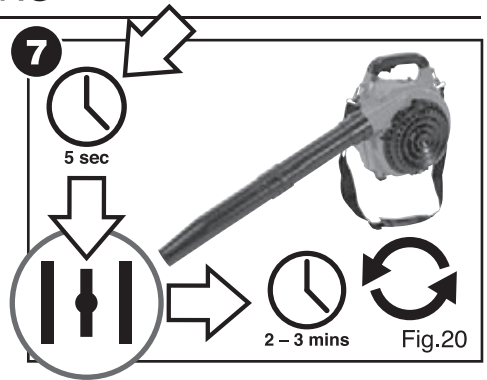

9.3 WARM STARTING THE ENGINE – FIGS. 21 – 23

Rest the blower/vac on a stable surface.

- 1 Press the ON/OFF/IGNITION switch (4) to the 'I' (ON) position.

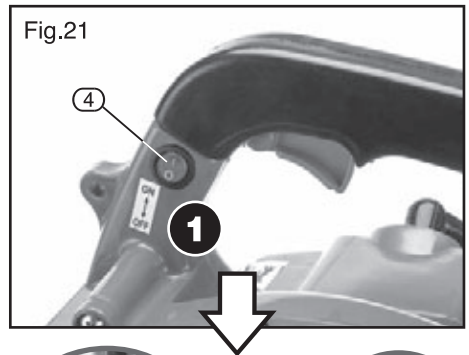

- 2 Push the choke lever (9) downwards to the ||| (open) position.
- 3 Pump the primer (17) eight times until fuel flows in and out of the discharge line (17.1) with no air bubbles.

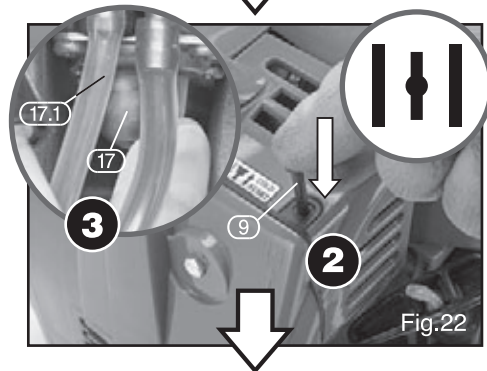

- 4 Standing behind the machine, firmly grip the front handle with your hand.
 - 5 With your other hand grip the recoil starter cord (10). Pull the starter cord using short sharp movements.
- If the engine does not start, refer to the steps highlighted in the previous section: **9.2 Cold Starting the Engine.**

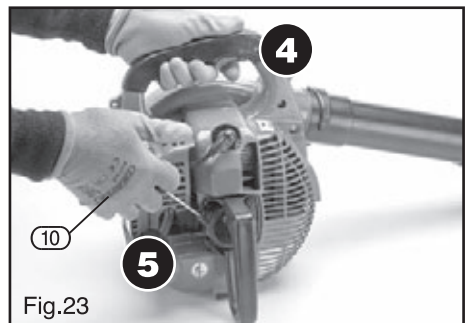

9. OPERATING INSTRUCTIONS

9.4 STOPPING THE ENGINE – FIG. 24

- 1 To stop the engine, move the stop switch (4) to the “stop” position.
- 2 **Note:** If the blower/vac has been running at full speed for a prolonged period allow the engine to idle for a few minutes before stopping.

The engine must be stopped while carrying out any other operation such as:

- Refuelling.
- Making checks or adjustments.
- Cleaning.

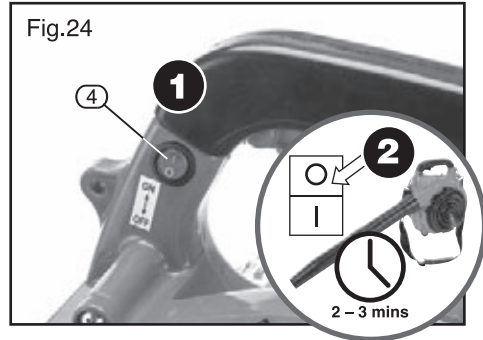

9.5 ADJUSTING THE ENGINE IDLE SPEED – FIGS. 25 – 26

Start the engine by following the steps highlighted in the previous section: **9.2 Cold Starting the Engine.**

- 1 Run the engine at idle speed until operating temperature is reached (2 – 3 minutes).
- 2 Use the supplied screwdriver (23) to adjust the engine idle speed to 2300 – 2500r/min.
- 3 Turn the idle screw (9.1) clockwise to increase engine idle speed. Turn the idle screw counterclockwise to decrease engine idle speed.

Warning! Machine tubes and intake cover must be installed while adjusting engine idle! Engine idle speed will also be affected if either the intake cover or machine tubes are blocked, damaged or incorrectly installed.

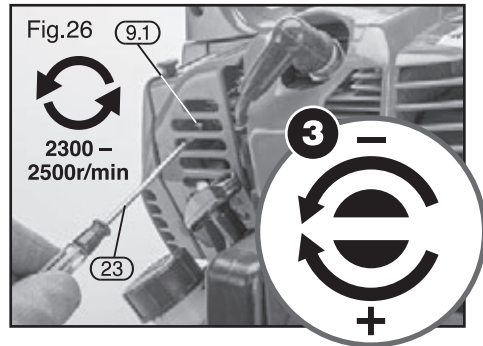
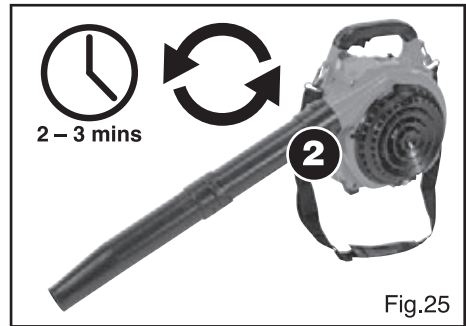

9. OPERATING INSTRUCTIONS



9.6 USING THE BLOWER/VAC – FIGS. 27 – 29

Note: As a general rule, try to operate the machine using the lowest throttle setting necessary for the task in hand.

Blower Operation – Figs. 27 – 28

Note: To set up the machine for blowing applications, refer to **Section 8: Assembling The Petrol Blower/Vac.**

- Use low throttle settings when clearing lightweight materials from around lawns or shrubbery.
- Use medium to higher throttle settings to move lightweight grass or leaves from open areas.
- Use full throttle when moving heavy loads such as dirt or snow.
- Machine noise increases at higher throttle settings. Always use the lowest possible throttle setting.

1 To keep from scattering debris, blow around the outer edges of a debris pile.

2 Never blow directly into the centre of a pile.

- Use rakes and brooms to loosen debris before blowing.
- In dusty conditions, slightly dampen surface with water (if available).

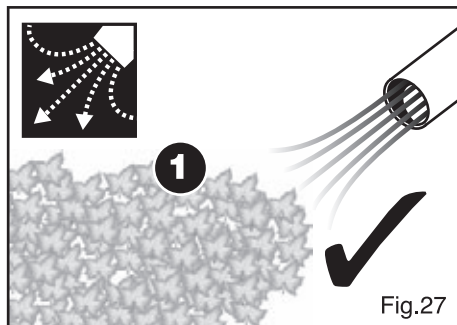

Fig.27

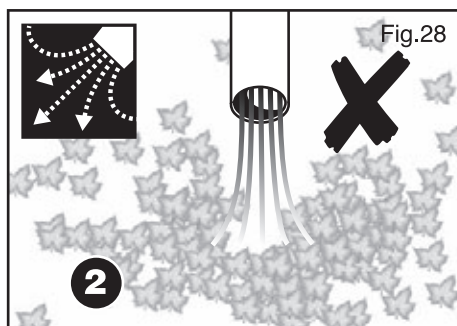

Fig.28

Vacuum Operation – Fig.29

Note: To set up the machine for vacuuming applications, refer to **Section 8: Assembling The Petrol Blower/Vac.**

- When using the machine in vacuuming operation, be sure not to allow the collection bag to become overfilled.
- Allowing the collection bag to become overfilled will reduce the appliances effectiveness and may cause damage to the bag itself or the appliance.

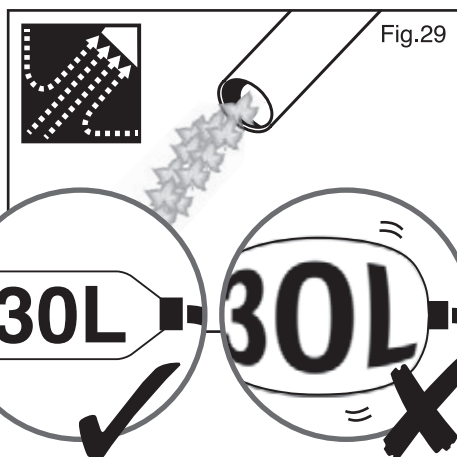

Fig.29

10. MAINTENANCE AND TROUBLESHOOTING

Regular maintenance tasks must be carried out at specific intervals to retain the engine's performance.

10.1 CLEANING THE AIR FILTER – FIGS. 30 – 32

A dirty, clogged air filter will restrict the air flow in to the engine and will cause rough running. It will increase fuel consumption and may result in starting problems.

Attention: Stop the engine before removing the air filter assembly.

- ➊ Pull the choke lever (9) upwards to the closed position to prevent any debris entering the carburettor inlet.
- ➋ Unscrew the retaining bolt (11.1) on the air filter cover (11) to remove it.
- ➌ Remove the air filter element (11.2).
- ➍ Wash the element in warm soapy water to clean it. Do not use solvents to clean it.
- ➎ Allow the filter to dry 100% before refitting it on to the engine.
 - Refit cover (11).
 - Replace the filter if it appears worn or damaged.

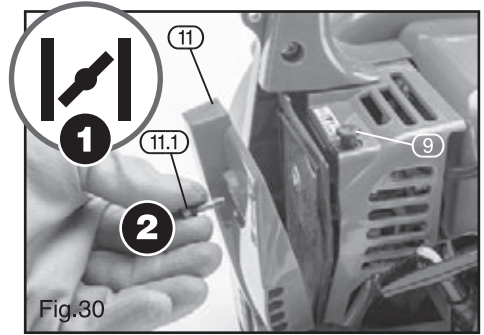

Fig.30

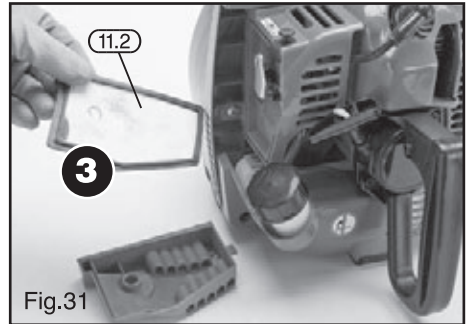

Fig.31

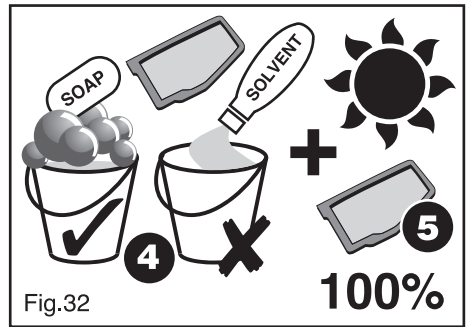

Fig.32

10.2 SPARK PLUG MAINTENANCE – FIGS. 33 – 34

Over time the spark plug (16.1) can become contaminated. This can be due to adverse running conditions such as, working with part throttle for a prolonged period or a fuel mix containing too much oil. This contamination can build up causing the engine to run roughly, reduce the fuel consumption or create starting problems.

- ➊ Without using any tools so as to avoid damaging the H.T. lead, remove the lead (16) from the back of the spark plug.

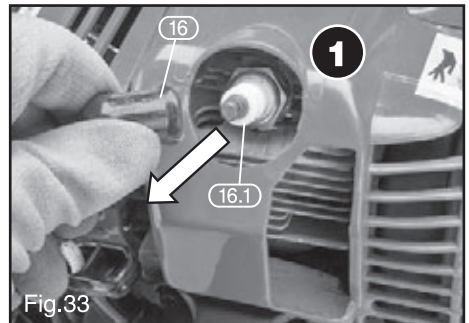
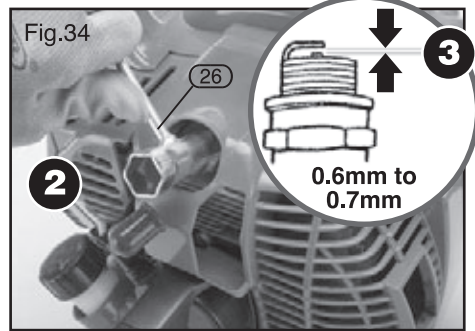

Fig.33

10. MAINTENANCE AND TROUBLESHOOTING

- 2 Using the spark plug box spanner supplied (26), turn the spark plug (16.1) anticlockwise to remove it.
- 3 Clean the spark plug and check the electrode gap. Maintain a gap of 0.6 to 0.7mm.
 - If required, replace the spark plug with a L7T coded plug, or equivalent, gapped to 0.6 – 0.7mm.

Warning! Make sure you correctly seat the spark plug thread in to the engine before screwing it clockwise in to the head.



10.3 CLEANING THE FUEL FILTER

The fuel tank is fitted with a filter.

- The filter is situated at the free end of the fuel pipe and can be picked out through the fuel port with a piece of hooked wire.
- Check the fuel filter periodically. Do not allow dust to enter the fuel tank. Clogged filter will cause difficulty when starting engine or abnormalities in engine performance.

Replace the filter if dirty.

When the inside of the fuel tank is dirty it can be cleaned by rinsing the tank out with petrol.

10.4 TROUBLESHOOTING GUIDE

Fault	Possible cause	Remedy
Engine does not start.	<ol style="list-style-type: none"> 1. No fuel in the tank. 2. The STOP/START switch is in the STOP position. 3. Ignition cable plug not firmly attached. 4. Ignition cable plug dirty. 5. Is there fuel inside the combustion chamber. 6. The spark plug is dirty. 7. The distance between the electrodes of the spark plug is too large. 8. Wrong fuel. 9. Spark plug defective. 	<ol style="list-style-type: none"> 1. Refuel tank. 2. Put the switch in the START position. 3. Push the plug on tightly. 4. Clean the plug. 5. Remove the spark plug, dry off the electrode and start at full throttle. 6. Clean the spark section. 7. Set the gap to 0.6 to 0.7mm. 8. Drain the tank and fill it with the correct fuel. 9. Replace the spark plug.
Machine runs but stutters.	<ol style="list-style-type: none"> 1. Is the choke set to the off (closed) position. 	<ol style="list-style-type: none"> 1. Set the choke to the on (open) position.

10. MAINTENANCE AND TROUBLESHOOTING

10.4 TROUBLESHOOTING GUIDE *(continued)*

Fault	Possible cause	Remedy
The motor does not reach its maximum speed.	<ol style="list-style-type: none">1. The air filter is dirty.2. The spark plug is dirty.3. The distance between the electrodes of the spark plug is too large.4. Wrong fuel.	<ol style="list-style-type: none">1. Clean the air filter.2. Clean the spark plug.3. Set the gap to 0.6 to 0.7mm.4. Drain the tank and fill with the correct fuel.

Important: Please note, all repairs/servicing should be carried out by a qualified person.

10.5 CLEANING AND MAINTENANCE OVERVIEW

Prior to every start.	
<ol style="list-style-type: none">1. Check/clean/replace air filter element.2. Check the pull starter for damage to the starter .3. Checking threaded connections for tightness.4. Remove dirt and debris from the machine's exterior5. Inspect engine cooling fins for accumulations of dirt and debris, clean as necessary.	<ol style="list-style-type: none">1. See section 10.1.2. Visual inspection/testing.3. Visual inspection/testing.4. Visual inspection.5. Visual inspection.
Every 10 operating hours (more frequently in dusty conditions).	
<ol style="list-style-type: none">1. Check/clean/replace air filter element.	<ol style="list-style-type: none">1. See section 10.1.
Every 10/15 operating hours.	
<ol style="list-style-type: none">1. Check/clean/replace spark plug.	<ol style="list-style-type: none">1. See section 10.2.
Every 50 operating hours. (more frequently for reduced engine performance).	
<ol style="list-style-type: none">1. Inspect the entire machine and tubes for damage, including loose or missing components and repair as necessary.2. Replace spark plug.3. Inspect/replace fuel filter.	<ol style="list-style-type: none">1. Visual inspection.2. See section 10.2.3. See section 10.3.

10.6 STORING THE MACHINE FOR AN EXTENDED PERIOD OF TIME (3 MONTHS OR LONGER)

Before an extended period of disuse, you must remove the fuel from the machine.

- Drain the fuel tank, then start the engine and let it run until it stops of its own accord.

11. EXPLANATION OF SYMBOLS

11.1 EXPLANATION OF SYMBOLS



Single value noise marking.
(Maximum declared
A-Weighted sound power level
in decibels).



Warning!
Hot surface.



Warning!
Wear suitable gloves.



Danger!
Risk of flying debris.



Warning!
Wear suitable foot protection.



Fuel/2-stroke oil mixture ratio.



Warning!
Wear suitable eye/face mask
protection.



Strictly no naked flames or
smoking near the appliance.



Warning!
Wear suitable ear protection.



Choke closed.



Warning!
Read the instruction manual.



Choke open.



Warning!
Keep out of the reach of children.



Danger from rotating impeller.



Warning!
Keep bystanders away.



Warning!
Risk of danger to wildlife.

12. DISPOSAL

12.1 DISPOSAL

- At the end of the machine's working life, or when it can no longer be repaired, ensure that it is disposed of according to national regulations.
- Contact your local authority for details of collection schemes in your area.

In all circumstances:

- Do not dispose of power tools with domestic waste.
- Do not incinerate.
- Do not abandon in the environment.
- When decommissioning (preparing the machine to be scrapped) drain any remaining fuel and oil for separate disposal.

CONTACTS

- **DRAPER TOOLS LIMITED,**
Hursley Road, Chandler's Ford,
Eastleigh, Hampshire. SO53 1YF. U.K.
- **Helpline:** (023) 8049 4344
- **Sales Desk:** (023) 8049 4333
- **Internet:** www.drapertools.com
- **E-mail:** sales@drapertools.com
- **Sales Fax:** (023) 8049 4209
- **General Enquiries:** (023) 8026 6355
- **Service/Warranty Repair Agent**
For aftersales servicing or warranty repairs, please contact the Draper Tools Helpline for details of an agent in your local area.

YOUR DRAPER STOCKIST

KCCH0217

©Published by Draper Tools Limited.

No part of this publication may be reproduced, stored in a retrieval system or transmitted in any form or by any means, electronic, mechanical photocopying, recording or otherwise without prior permission in writing from Draper Tools Ltd.