



# Riveter Kit

Stock No.33746 Part No.4296K

KEY No.	PART No.	STOCK No.	DESCRIPTION
1	Y107163	61527	3/16" Nosepiece
1	Y106160	62146	3/32" Nosepiece
1	Y107161	62147	1/8" Nosepiece
1	Y107162	62152	5/32" Nosepiece
2	Y02115	33943	Head
3	Y10709	33944	Jaw Housing
4	Y107B08	61530	Jaw (2)
5	Y107B07	33946	Jaw Pusher
6	Y02105	61532	Spring
7	Y10548	61560	"O" Ring Seal (3)
8	Y02106	33949	Jaw Housing Coupler
9	Y02104	61535	Nut
10	Y11520	61536	"X" Ring Seal
11	Y11558	61537	Ring Washer (4)
12	Y02102	33953	Hydraulic Section
13	Y02171	61539	Oil Plug
14	Y021510	61540	Hydraulic Plunger
15	Y11501	61541	"O" Ring Seal
16	Y11549	61542	"O" Ring Washer
17	Y02152	61543	Return Spring
18	Y02153	61544	Return Spring
19	Y02127	61545	"O" Ring Seal
20	Y02159	61546	Hanging Ring
21	Y02110	61547	Screw Plug
22	Y02123	33981	Piston Disc
23	Y02124	33982	Air Piston Ring
24	Y20412	61578	"O" Ring Seal
25	Y76527	33983	Spring Washer
26	Y10427	33984	Screw
27	Y02122	33980	Plunger Rod

KEY No.	PART No.	STOCK No.	DESCRIPTION
28	Y02130	33979	Damping Ring
29	Y25022	61554	"O" Ring Seal
30	Y02157	33970	Screw Plug
31	Y02101	33972	Air Cylinder
32	Y02116	33971	"O" Ring Seal
33	Y10431	33985	"O" Ring Seal
34	Y02103	33986	Air Cylinder Cap
35	Y02197	61291	"O" Ring Seal
36	Y02139	33974	Valve Tube
37	Y11541	61573	Valve Tube Spring
38	Y11560	61561	"O" Ring Seal
39	Y400060	33976	Valve Plate
40	Y10544	61563	Spring
41	Y10550	61564	Plug Screw
42	Y02121	61558	Lock Nut
43	Y02167	61553	Pin
44	Y02134	33967	Trigger Lever
45	Y02168H	61548	Pin
46	Y02169	61549	Pin
47	YN2 5X6	61579	Pin
48	Y02133	61551	Trigger Rod
49	Y02172	86075	Set Screw
50	Y10647	62145	Wrench
51	Y02138H	61550	Trigger
52	Y02160	62156	Safety Cap
53	Y02147	61576	Air Inlet Plug
54	Y02146	61575	1/4" Air Inlet Fitting
55	Y02149	61574	Retaining Ring
56	Y??????	89733	"O" Ring Seal

**Helpline: (023) 8049 4344. Sales Desk: (023) 8049 4333. General Enquiries: (023) 8026 6355.**



SPARE PARTS DRAWING SHEET FOR

# Riveter Kit

Stock No.33746 Part No.4296K

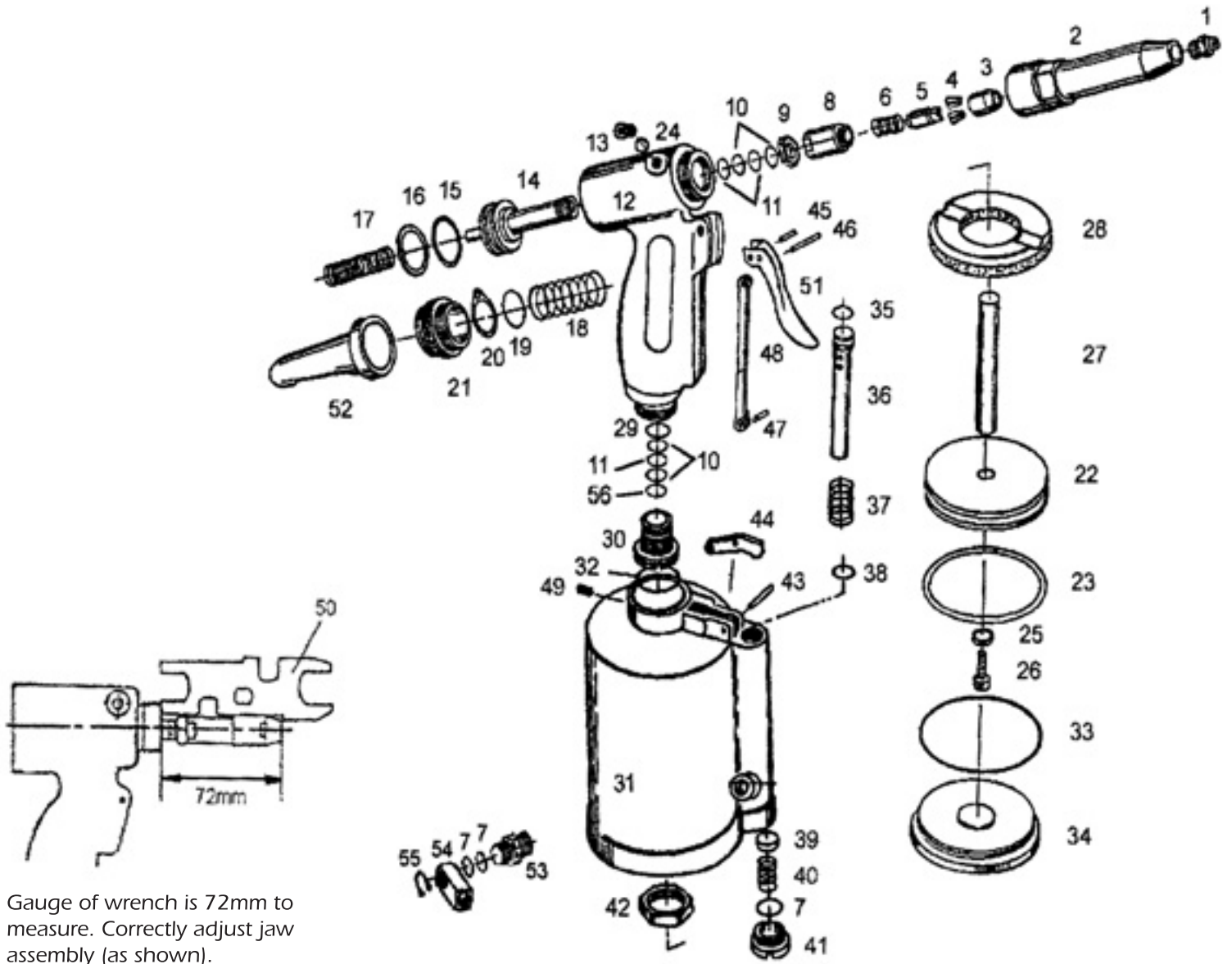

Gauge of wrench is 72mm to measure. Correctly adjust jaw assembly (as shown).

**Helpline:** (023) 8049 4344. **Sales Desk:** (023) 8049 4333. **General Enquiries:** (023) 8026 6355.

DRAPER TOOLS LTD, HURSLEY ROAD, CHANDLER'S FORD, EASTLEIGH, HANTS. SO53 1YF. U.K. internet: [www.draper.co.uk](http://www.draper.co.uk) e-mail: [sales@drapertools.com](mailto:sales@drapertools.com)  
OAH230106