

# DRAPER®

## INSTRUCTIONS FOR 350W Submersible Water Butt Pumps

Stock No.36327  
36376  
38241

Part No.WBP2A  
WBP3A  
SWBP4A

**IMPORTANT:** PLEASE READ THESE INSTRUCTIONS CAREFULLY TO ENSURE THE SAFE AND EFFECTIVE USE OF THIS PRODUCT.



Stock No.38241



Stock No.36327



Stock No.36376

### DRAPER®

## GENERAL INFORMATION

These instructions accompanying the product are the original instructions. This document is part of the product, keep it for the life of the product passing it on to any subsequent holder of the product. Read all these instructions before assembling, operating or maintaining this product.

This manual has been compiled by Draper Tools describing the purpose for which the product has been designed, and contains all the necessary information to ensure its correct and safe use. By following all the general safety instructions contained in this manual, it will ensure both product and operator safety, together with longer life of the product itself.

All photographs and drawings in this manual are supplied by Draper Tools to help illustrate the operation of the product.

Whilst every effort has been made to ensure the accuracy of information contained in this manual, the Draper Tools policy of continuous improvement determines the right to make modifications without prior warning.

# 1. TITLE PAGE

---

## **1.1 INTRODUCTION:**

USER MANUAL FOR:

## **SUBMERSIBLE WATER BUTT PUMPS**

<b>Stock No's:</b>	36327,	36376,	38241.
<b>Part No's:</b>	WBP2A,	WBP3A,	SWBP4A.
<b>Pump type:</b>	230V AC	12V DC Li-ion battery powered.	Solar powered 12V DC with Li-ion battery.

## **1.2 REVISIONS:**

Date first published November 2014.

---

---

---

---

As our user manuals are continually updated, users should make sure that they use the very latest version.

Downloads are available from: <http://www.drapertools.com/b2c/b2cmanuals.pgm>

DRAPER TOOLS LIMITED

HURSLEY ROAD

CHANDLER'S FORD

EASTLEIGH

HAMPSHIRE

SO53 1YF

UK

WEBSITE: [www.drapertools.com](http://www.drapertools.com)

PRODUCT HELPLINE: +44 (0) 23 8049 4344

GENERAL FAX: +44 (0) 23 8026 0784

## **1.3 UNDERSTANDING THIS MANUALS SAFETY CONTENT:**

**WARNING!** Information that draws attention to the risk of injury or death.

**CAUTION!** Information that draws attention to the risk of damage to the product or surroundings.

**NOTE!** Important information.

## **1.4 COPYRIGHT © NOTICE:**

Copyright © Draper Tools Limited.

Permission is granted to reproduce this publication for personal & educational use only.

Commercial copying, redistribution, hiring or lending is prohibited.

No part of this publication may be stored in a retrieval system or transmitted in any other form or means without written permission from Draper Tools Limited.

In all cases this copyright notice must remain intact.

---

## 2. CONTENTS

---

### 2.1 CONTENTS

<b>Page content</b>		<b>Page</b>
1	TITLE PAGE	
	1.1 INTRODUCTION .....	2
	1.2 REVISION HISTORY .....	2
	1.3 UNDERSTANDING THIS MANUAL .....	2
	1.4 COPYRIGHT NOTICE .....	2
2	CONTENTS	
	2.1 CONTENTS .....	3
3	GUARANTEE	
	3.1 GUARANTEE .....	4
4	INTRODUCTION	
	4.1 SCOPE .....	5
	4.2 SPECIFICATION .....	5
	4.3 HANDLING & STORAGE .....	5
5	HEALTH & SAFETY INFORMATION	
	5.1 GENERAL SAFETY INSTRUCTIONS FOR WATER BUTT PUMP USE .....	6
	5.2 SPECIFIC SAFETY INSTRUCTIONS FOR PUMP USE .....	7
	5.3 CONNECTION TO THE POWER SUPPLY .....	7
6	TECHNICAL DESCRIPTION	
	6.1 IDENTIFICATION .....	8
7	UNPACKING & CHECKING	
	7.1 PACKAGING .....	10
8	ASSEMBLING THE WATER BUTT PUMP	
	8.1 EXTENSION TUBES .....	11
9	OPERATING THE WATER BUTT PUMP	
	9.1 HORIZONTAL PUMPING DISTANCE .....	12
	9.2 CONNECTION TO HOSE/CHARGING THE BATTERY .....	12
	9.3 INSTALLATION .....	13
	9.4 POSITIONING THE PUMP .....	13
	9.5 FLOW REGULATING .....	13
10	MAINTENANCE	
	10.1 FILTER REMOVAL .....	14
11	TROUBLESHOOTING	
	11.1 TROUBLESHOOTING .....	15
12	DISPOSAL	
	12.1 DISPOSAL .....	16
13	EXPLANATION OF SYMBOLS	
	13.1 EXPLANATION OF SYMBOLS .....	17
	DECLARATION OF CONFORMITY .....	ENCLOSED

## 3. GUARANTEE

---

### 3.1 GUARANTEE

Draper tools have been carefully tested and inspected before shipment and are guaranteed to be free from defective materials and workmanship.

Should the tool develop a fault, please return the complete tool to your nearest distributor or contact Draper Tools Limited, Chandler's Ford, Eastleigh, Hampshire, SO53 1YF. England.

Telephone Sales Desk: (023) 8049 4333 or Product Helpline (023) 8049 4344.

A proof of purchase must be provided with the tool.

If upon inspection it is found that the fault occurring is due to defective materials or workmanship, repairs will be carried out free of charge. This guarantee period covering parts/labour is 12 months from the date of purchase except where tools are hired out when the guarantee period is ninety days from the date of purchase. The guarantee is extended to 24 months for parts only. This guarantee does not apply to normal wear and tear, nor does it cover any damage caused by misuse, careless or unsafe handling, alterations, accidents, or repairs attempted or made by any personnel other than the authorised Draper warranty repair agent.

Note: If the tool is found not to be within the terms of warranty, repairs and carriage charges will be quoted and made accordingly.

This guarantee applies in lieu of any other guarantee expressed or implied and variations of its terms are not authorised.

Your Draper guarantee is not effective unless you can produce upon request a dated receipt or invoice to verify your proof of purchase within the guarantee period.

Please note that this guarantee is an additional benefit and does not affect your statutory rights.

Draper Tools Limited.

# 4. INTRODUCTION

---

## 4.1 SCOPE

These pumps are designed for pumping rain water out of a water butt for garden/plant watering.

## 4.2 SPECIFICATION

Stock No. ....	36327	36376	38241
Part No. ....	WBP2A	WBP3A	SWBP4A
Rated voltage .....	230V AC 50Hz	12V DC	12V DC
Rated input .....	350W	65W	65W
Maximum total head .....	11M	11M	11M
Maximum operating depth .....	3M	3M	3M
Maximum output .....	2500L/hr	1700L/hr	1700L/hr
Maximum particle size Ø .....	3mm	3mm	3mm
Maximum liquid temp. ....	35°C	35°C	35°C
Output diameter .....	19mm	19mm	19mm
Ingress protection .....	IPX8	IPX8	IPX8
Continuously rated .....	No	No	No
Thermal overload protection .....	YES	YES	YES

\*On time: 30mins  
Off time: 10mins

**WARNING:** The pump must be supplied through a residual current device (RCD) having a rated residual operating current not exceeding 30mA.

## 4.3 HANDLING & STORAGE

Although these machines are small in size, care must still be taken when handling and lifting. Dropping these machines will have an effect on the accuracy and may also result in personal injury. This machine is not a toy and must be respected.

The environment will have a negative result on its operation if you are not careful. If the air is damp, components will rust. If these machines are unprotected from dust and debris; components will become clogged: And if not cleaned and maintained correctly or regularly the machine will not perform at its best.

## 5. HEALTH & SAFETY INFORMATION

---

### **5.1 GENERAL SAFETY INSTRUCTIONS FOR WATER BUTT PUMP USE**

When carrying or lifting the submersible water butt pump always use the transport handle, **DO NOT** carry or lift using the power cable.

The pump must not be used when people are in the water.

The pump must be supplied through a residual current device (RCD) having a rated residual operating current not exceeding 30mA.

35°C maximum liquid temperature.

The electrical supply should be the same as that stated on the rating plate.

Submersible water pumps should always be transported, stored, and submersed vertically.

Always ensure that hands are dry when connecting and disconnecting the power supply.

Never operate the pump below the top of the water inlet.

The area being pumped should be kept clear, and nobody should enter the area while pump is operating.

#### **IMPORTANT: PLEASE READ BEFORE USE:**

The following additional instructions must be followed at all times. Failure to do so could invalidate the guarantee of this submersible water pump.

Clean water pumps are **NOT** suitable for use in dirty water.

**NOTE:** The pump, should be suspended using a rope or chain or stood on a brick to prevent any gravel etc. being sucked into the pump.

If pump fails to operate, disconnect from mains supply. Remove the base (see page 6) and gently turn the impeller using a screwdriver. Check for obstruction in the impeller, i.e. stones/gravel etc.

If the power cable becomes damaged it must be changed by the manufacturer or it's service agents.

**IMPORTANT:** Any pump returned to Draper Tools Ltd under warranty must be CLEAN. If a pump is received that has **NOT** been cleaned, it will be returned to you at your cost.

## 5. HEALTH & SAFETY INFORMATION

---

### 5.2 SPECIFIC SAFETY INSTRUCTIONS FOR PUMP USE

**Have this tool repaired by a qualified person.** This tool is designed to conform to the relevant international and local standards and as such should be maintained and repaired by someone qualified; using only original parts supplied by the manufacturer: This will ensure the tool remains safe to use.

1. Before connecting to the power supply:
  - i. A residual current circuit breaker (RCD) must be used for all applications.
  - ii. The electrical supply should be the same as stated on the rating plate.
2. Surface mounted pumps should always be transported and stored horizontally on the base plate.
3. Always ensure that hands are dry when connecting and disconnecting the power supply.
4. Never operate the pump dry.
5. The area being pumped should be kept clear, nobody should enter area while pump is operating.

THE FOLLOWING ADDITIONAL INSTRUCTIONS MUST BE FOLLOWED AT ALL TIMES. FAILURE TO DO SO COULD INVALIDATE THE GUARANTEE OF THIS SUBMERSIBLE WATER PUMP.

1. The float switch must be clamped in position using cable clamp recess (see page 9, fig.10).
2. Clean water pumps are not suitable for use in dirty water.
3. These water pumps are designed for pumping water only.  
The addition of any chemicals, chlorine or additives to the water could damage the pump, this would be considered misuse and would not be covered under warranty.
4. When using clean water pumps in a pond or where there is gravel, mud, leaves, etc.  
NOTE: The pump, should be suspended using a rope or chain or stood on a brick to prevent any gravel, etc., being sucked into the pump.
5. If the pump fails to operate, disconnect from mains supply. Remove output elbow and turn the impeller using a screwdriver or finger. Check for obstruction in the impeller, i.e. stones/gravel, etc.
6. The float switch fitted to this pump is not suitable for continuous use as an on/off switch.  
**IMPORTANT: ANY PUMP RETURNED TO DRAPER TOOLS UNDER WARRANTY MUST BE CLEAN. IF A PUMP IS RECEIVED THAT IS NOT, OR HAS NOT BEEN CLEANED, IT WILL BE RETURNED TO YOU AT YOUR COST.**

### 5.3 CONNECTION TO THE POWER SUPPLY

Make sure the power supply information on the machine's rating plate are compatible with the power supply you intend to connect it to.

This water pump comes supplied with a UK standard 3 pin plug fitted. It is designed for connection to a domestic power supply rated at 230V AC.

Apart from replacing the fuse in the plug, no other electrical work is recommended on this water pump.

# 6. TECHNICAL DESCRIPTION

## 6.1 IDENTIFICATION

**Stock No.38241**

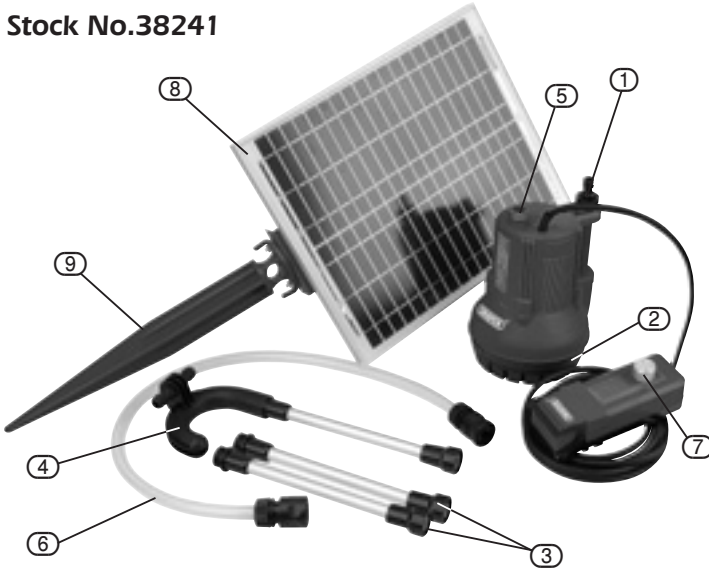

- ① Extension pipe connection.
- ② Filtered inlet.
- ③ Straight extension pieces.
- ④ Curved extension piece.
- ⑤ Male hose connector/pump outlet.
- ⑥ Hose.
- ⑦ Flow control and On/Off switch.
- ⑧ Solar Panel.
- ⑨ Ground spike.
- ⑩ Charger (not shown).

**Stock No.36376**



- ① Extension pipe connection.
- ② Filtered inlet.
- ③ Straight extension pieces.
- ④ Curved extension piece.
- ⑤ Male hose connector/pump outlet.
- ⑥ Hose.
- ⑦ Flow control and On/Off switch.
- ⑧ Charger (not shown).



## 6. TECHNICAL DESCRIPTION

---

*Stock No.36327*



- ① Extension pipe connection.
- ② Filtered inlet.
- ③ Straight extension piece × 2.
- ④ Curved extension piece.
- ⑤ Male hose connector/pump outlet.
- ⑥ Moulded plug & cable.
- ⑦ Float switch.

# 7. UNPACKING & CHECKING

---

## **7.1 PACKAGING**

Carefully remove the product from the packaging and examine it for any sign of damage that may have happened during shipping. Lay the contents out and check them against your particular model, identified in the Technical Description sections on pages 8 and 9. If any part is damaged or missing; please contact the Draper Helpline (the telephone number appears on the Title page) and do not attempt to use the product.

The packaging material should be retained at least during the guarantee period: in case the machine needs to be returned for repair.

**Warning!** Some of the packaging materials used may be harmful to children. Do not leave any of these materials in the reach of children.

If any of the packaging is to be thrown away, make sure they are disposed of correctly; according to local regulations.

## 8. ASSEMBLING THE WATER BUTT PUMP

**NOTE:** Remove the plug from the socket before carrying out adjustment, servicing or maintenance.

### 8.1 EXTENSION TUBES - FIGS.1 - 2

Attach the straight extension piece (3) to the threaded spigot (1) by tightening clockwise.

Ensure seal is installed correctly to achieve a water tight connection.

Screw the curved extension piece (4) onto the straight extension (3) piece by tightening ring (4.1).

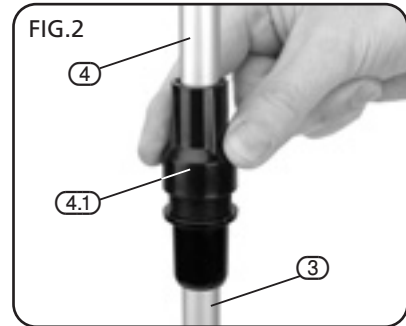
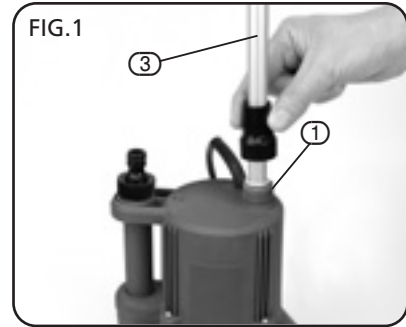

## 9. OPERATING THE WATER BUTT PUMP

---

### 9.1 HORIZONTAL PUMPING DISTANCE

The horizontal pumping distance is directly affected by the working head height (maximum total head minus measured working head height, times factor of 10, equals the approximate horizontal pumping distance in metres using solid delivery hose).

For example: maximum total head is 7M, minus actual working head of 3M, equals  $4\text{M} \times 10 = 40\text{M}$  approximate pumping distance.

### 9.2 CONNECTION TO HOSE - FIGS. 3 - 4

Make connection to the pump outlet with a quick connector (5.1) on a length of hose. On the other end of the hose, connect an appropriate accessory suitable for the intended application.

### CHARGING THE BATTERY (36376, 38241 only)

To charge the battery connect the transformer plug adaptor to the charging port on the battery pack and then switch on the mains socket. The transformer plug adaptors LED will light red to indicate charging and will change to green once charged.

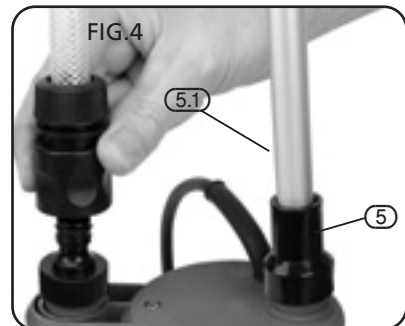
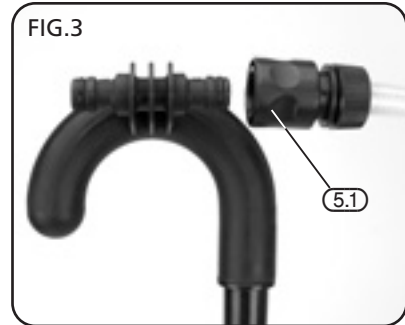

## 9. OPERATING THE WATER BUTT PUMP

### 9.3 INSTALLATION - FIG. 5

The pump must be fully submersed before the power is switched on. Do not turn the pump on when its dry.

#### Models 36376 & 38241

These models include a Li-ion (Lithium Ion) battery.

This battery must be fully charged before use.

- **Model 36376** achieves this by means of a mains charger. Charging of the battery should always be done indoors away from rain or other water.
- **Model 38241** achieves charging of the battery by means of the mains charger as detailed for the model above. Model 38241 also benefits from a solar panel, the solar panel when connected to the battery will provide a trickle charge to the battery, this is designed to be able to keep the battery charge topped up (actual charge applied to battery depends on available sunlight and suitable positioning of the solar panel). On occasions of low sun or sunlight not directly striking the solar panel the use of the mains charger may be required to complete the charging of the battery.

### 9.4 POSITIONING THE PUMP - FIGS. 6 - 7

When submersing or lifting the pump it is necessary to use a rope or chain, this must only be attached to the transport handle. If pumping water from a sandy or muddy water butt, the pump can be suspended using a rope or chain (not supplied) fixed to the handle. Do not use any of the electric cables for this purpose, alternatively, stand the pump on a brick to raise it up from the dirt.

\*Actual handle position on pump may differ from illustration.

### 9.5 FLOW REGULATING - FIG. 8

When the pump is operating the flow of water can be reduced. Turn flow control (7) to regulate accordingly.

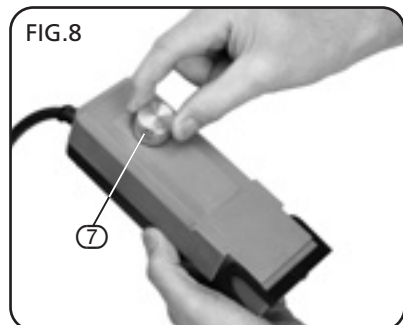
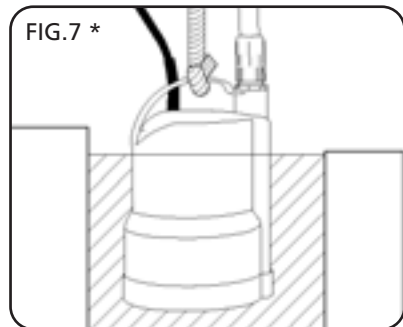
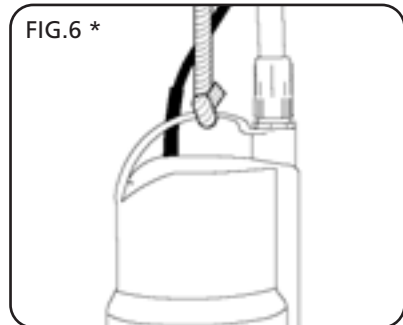
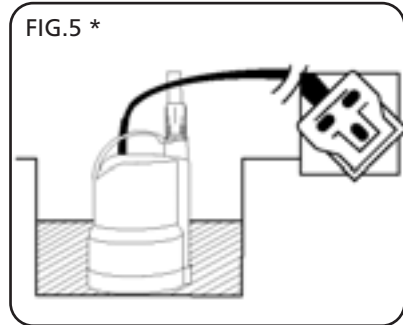

# 10. MAINTENANCE

---

**NOTE:** Remove the plug from the socket before carrying out adjustment, servicing or maintenance.

If the replacement of the power cable is necessary, this has to be done by the manufacturer or his agent in order to avoid a safety hazard.

## **10.1 FILTER REMOVAL - FIGS. 9 - 10**

From time to time it will be necessary to remove and clean/replace the inlet filter.

With the pump disconnected from the power supply, turn the unit over to expose the base (2).

Release clips (2.2) and to remove filter base, exposing filter as shown.

Remove the filter (2.1) and rinse thoroughly with clean water. Install the filter and secure the filter base.

Never use the pump with the filter and the cover removed.

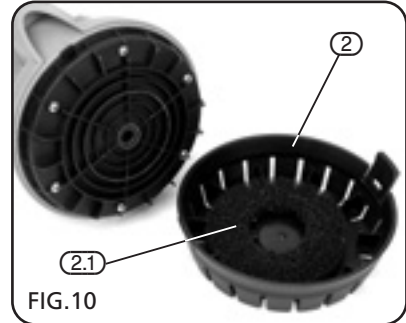
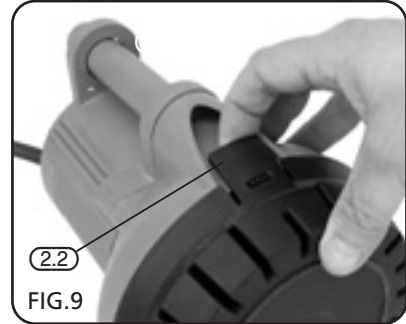

# 11. TROUBLESHOOTING

## 11.1 TROUBLESHOOTING

**WARNING:** For your own safety always turn the main switch on the machine "off" and remove the plug from the power supply before carrying out any maintenance or trouble shooting.

Problem	Cause	Remedy
No power	<ol style="list-style-type: none"><li>1. Fuse.</li><li>2. Battery is not charged.</li><li>3. Other.</li></ol>	<ol style="list-style-type: none"><li>1. Reset/replace time delay fuse or circuit breaker.</li><li>2. Charge the battery.</li><li>3. Return to service agent.</li></ol>
Pump running but not delivering water	<ol style="list-style-type: none"><li>1. Insufficient water level.</li><li>2. Inlet clogged.</li><li>3. Hose crimped.</li></ol>	<ol style="list-style-type: none"><li>1. Raise water level (where applicable).</li><li>2. Clean.</li><li>3. Straighten hose.</li></ol>
Pump stops running, due to thermal overload coming into operation.	<ol style="list-style-type: none"><li>1. Solid jammed in pump.</li><li>2. Excessive water temperature.</li><li>3. Pump ran dry.</li></ol>	<ol style="list-style-type: none"><li>1. Raise water level (where applicable). Clear jammed solid from pump inlet, raise pump above any silt before turning on again</li><li>2. Water temperature must not exceed 35°C.</li><li>3. Adjust water level.</li></ol>

# 12. DISPOSAL

---

## 12.1 DISPOSAL

- At the end of the machine's working life, or when it can no longer be repaired, ensure that it is disposed of according to national regulations.
- Contact your local authority for details of collection schemes in your area.

In all circumstances:

- Do not dispose of power tools with domestic waste.
- Do not incinerate.
- Do not abandon in the environment.
- Do not dispose of WEEE\* as unsorted municipal waste.



\* Waste Electrical & Electronic Equipment.



# 13. EXPLANATION OF SYMBOLS

---

## 13.1 EXPLANATION OF SYMBOLS



WEEE

Do not dispose of Waste Electrical  
& Electronic Equipment in with  
domestic rubbish

\* Waste Electrical & Electronic Equipment.





- **DRAPER TOOLS LIMITED,**  
Hursley Road, Chandler's Ford,  
Eastleigh, Hampshire. SO53 1YF. U.K.
- **Helpline:** (023) 8049 4344
- **Sales Desk:** (023) 8049 4333
- **Website:** [www.drapertools.com](http://www.drapertools.com)
- **E-mail:** [sales@drapertools.com](mailto:sales@drapertools.com)
- **Sales Fax:** (023) 8049 4209
- **General Enquiries:** (023) 8026 6355
- **Service/Warranty Repair Agent**  
For aftersales servicing or warranty repairs, please  
contact the Draper Tools Helpline for details of an  
agent in your local area.

YOUR DRAPER STOCKIST