

DRAPER[®]

D20
MULTI-TOOL BATTERY SYSTEM

GB

20V BRUSHLESS

NIBBLER

55742



CE

These instructions accompanying the product are the original instructions. This document is part of the product, keep it for the life of the product passing it on to any subsequent holder of the product. Read all these instructions before assembling, operating or maintaining this product.

This manual has been compiled by Draper Tools describing the purpose for which the product has been designed, and contains all the necessary information to ensure its correct and safe use. By following all the general safety instructions contained in this manual, it will ensure both product and operator safety, together with longer life of the product itself.

All photographs and drawings in this manual are supplied by Draper Tools to help illustrate the operation of the product.

Whilst every effort has been made to ensure the accuracy of information contained in this manual, the Draper Tools policy of continuous improvement determines the right to make modifications without prior warning.

1. TITLE PAGE

1.1 INTRODUCTION:

USER MANUAL FOR: 20V Brushless Nibbler

Stock No: 55742

Part No: D20NS1700

1.2 REVISIONS:

Date first published January 2019.

As our user manuals are continually updated, users should make sure that they use the very latest version.

Downloads are available from: <http://drapertools.com/manuals>

Draper Tools Limited
Hursley Road
Chandler's Ford
Eastleigh
Hampshire
SO53 1YF
UK

Website: drapertools.com

Product help line: +44 (0) 23 8049 4344

General Fax: +44 (0) 23 8026 0784

1.3 UNDERSTANDING THIS MANUALS SAFETY CONTENT:

WARNING! – Information that draws attention to the risk of injury or death.

CAUTION! – Information that draws attention to the risk of damage to the product or surroundings.

1.4 COPYRIGHT © NOTICE:

Copyright © Draper Tools Limited.

Permission is granted to reproduce this publication for personal and educational use only. Commercial copying, redistribution, hiring or lending is prohibited.

No part of this publication may be stored in a retrieval system or transmitted in any other form or means without written permission from Draper Tools Limited.

In all cases this copyright notice must remain intact.

2. CONTENTS

1. TITLE PAGE	
1.1 INTRODUCTION	2
1.2 REVISION HISTORY	2
1.3 UNDERSTANDING THIS MANUAL	2
1.4 COPYRIGHT NOTICE	2
2. CONTENTS	
2.1 CONTENTS	3
3. WARRANTY	
3.1 WARRANTY	4
4. INTRODUCTION	
4.1 SCOPE	5
4.2 SPECIFICATION	5
4.3 HANDLING & STORAGE	5
5. HEALTH AND SAFETY INFORMATION	
5.1 GENERAL SAFETY INSTRUCTIONS FOR POWER TOOL USE	6-7
5.2 SPECIFIC SAFETY INSTRUCTIONS FOR NIBBLERS	7
5.3 RESIDUAL RISK	7
6. TECHNICAL DESCRIPTION	
6.1 IDENTIFICATION	8
7. UNPACKING AND CHECKING	
7.1 PACKAGING	9
7.2 D20 MULTI-TOOL INTERCHANGEABLE BATTERY SYSTEM	9
7.3 WHAT'S IN THE BOX	9
8. PREPARING THE NIBBLER	
8.1 CUTTING HEAD POSITION AND DIRECTION CHANGING	10
8.2 CUTTING THICKNESS	10
8.3 SWITCH	11
8.4 SUPPORT HANDLE	11
8.5 REMOVING AND INSTALLING HEADS	12-13
9. BASIC NIBBLER OPERATION	
9.1 CUTTING METHOD	14
10. MAINTENANCE	
10.1 MAINTENANCE	15
11. OPTIONAL ACCESSORIES	
11.1 OPTIONAL ACCESSORIES	16
12. DISPOSAL	
12.1 DISPOSAL	7
13. EXPLANATION OF SYMBOLS	
13.1 EXPLANATION OF SYMBOLS	18
DECLARATION OF CONFORMITY	ENCLOSED

3. WARRANTY

3.1 WARRANTY

Draper tools have been carefully tested and inspected before shipment and are guaranteed to be free from defective materials and workmanship.

Should the tool develop a fault, please return the complete tool to your nearest distributor or contact

Draper Tools Limited, Chandler's Ford, Eastleigh, Hampshire, SO53 1YF. England.

Telephone Sales Desk: (023) 8049 4333 or Product Help Line (023) 8049 4344.

A proof of purchase must be provided with the tool.

If upon inspection it is found that the fault occurring is due to defective materials or workmanship, repairs will be carried out free of charge. This warranty period covering labour is 12 months from the date of purchase except where tools are hired out when the warranty period is 90 days from the date of purchase. The warranty is extended to 24 months for parts only. This warranty does not apply to any consumable parts, any type of battery or normal wear and tear, nor does it cover any damage caused by misuse, careless or unsafe handling, alterations, accidents, or repairs attempted or made by any personnel other than the authorised Draper warranty repair agent.

Note: If the tool is found not to be within the terms of warranty, repairs and carriage charges will be quoted and made accordingly.

This warranty applies in lieu of any other warranty expressed or implied and variations of its terms are not authorised.

Your Draper warranty is not effective unless you can produce upon request a dated receipt or invoice to verify your proof of purchase within the warranty period.

Please note that this warranty is an additional benefit and does not affect your statutory rights.

Draper Tools Limited.

4. INTRODUCTION

4.1 SCOPE

This tool is intended for cutting curves and straight lines on sheet metal.

As part of our core range, this product is suitable for enthusiasts and tradespeople alike.

Any application other than that it was intended for, is considered misuse.

4.2 SPECIFICATION

Stock No.	55742
Part No.	D20NS1700
Rated voltage	20V
Speed (no load)	1700spm
Maximum thickness of sheet	1.2mm
Minimum cutting radius (freehand nibblers)	25mmØ
Sound pressure level (LpA)*:	80.67dB(A)
Sound power level (LWA)**:	91.67dB(A)
Uncertainty (K):	3dB(A)
Vibration level when cutting metal†:	11.16mm/s ² , K=1.5m/s ²
Weight (machine only):	2.7kg

* *Continuous A-Weighted Sound Pressure Level at the workstation in accordance to and declared according to EN60745.*

** *The typical A-weighted noise level determined according to EN60745.*

4.3 HANDLING & STORAGE

- Care must be taken when handling this product.
 - Dropping this power tool could have an effect on its accuracy and could also result in personal injury. This product is not a toy and must be respected.
- Environmental conditions can have a detrimental effect on this product if neglected.
 - Exposure to damp air can gradually corrode components.
 - If the product is unprotected from dust and debris, components will become clogged.
 - If not cleaned and maintained correctly or regularly, the machine will not perform at its best.

5. HEALTH AND SAFETY INFORMATION

5.1 GENERAL SAFETY INSTRUCTIONS FOR POWER TOOL USE

When using any type of power tool there are steps that should be taken to make sure that you, as the user, remain safe.

Common sense and a respect for the tool will help reduce the risk of injury.

Read the instruction manual fully. Do not attempt any operation until you have read and understood this manual.

Most important you must know how to safely start and stop this machine, especially in an emergency.

Keep the work area tidy and clean. Attempting to clear clutter from around the machine during use will reduce your concentration. Mess on the floor creates a trip hazard. Any liquid spill on the floor could result in you slipping.

Find a suitable location. If the machine is bench mounted, the location should provide good natural light or artificial lighting as a replacement. Avoid damp and dust locations as it will have a negative effect on the machine's performance. If the machine is portable do not expose the tool to rain. In all cases do not operate power tools near any flammable materials.

Keep bystanders away. Children, onlookers and passers by must be restricted from entering the work area for their own protection. The barrier must extend a suitable distance from the tool user.

Unplug and house all power tools that are not in use. A power tool should never be left unattended while connected to the power supply. They must be housed in a suitable location, away locked up and from children. This includes battery chargers.

Do not overload or misuse the tool. All tools are designed for a purpose and are limited to what they are capable of doing. Do not attempt to use a power tool (or adapt it in any way) for an application it is not designed for. Select a tool appropriate for the size of the job. Overloading a tool will result in tool failure and user injury. This covers the use of accessories.

Dress properly. Loose clothing, long hair and jewellery are all dangerous because they can become entangled in moving machinery. This can also result in parts of body being pulled into the machine. Clothing should be close fitted, with any long hair tied back and jewellery and neck ties removed. Footwear must be fully enclosed and have a non-slip sole.

Wear personal protective equipment (PPE). Dust, noise, vibration and swarf can all be dangerous if not suitably protected against. If the work involving the power tool creates dust or fumes wear a dust mask. Vibration to the hand, caused by operating some tools for longer periods must be protected against. Wear vibration reducing gloves and allow long breaks between uses. Protect against dust and swarf by wearing approved safety goggles or a face shield. These are some of the more common hazards and preventions, however, always find out what hazards are associated with the machine/work process and wear the most suitable protective equipment available.

Do not breathe contaminated air. If the work creates dust or fumes connect the machine (if possible) to an extraction system either locally or remotely. Working outdoors can also help if possible.

Move the machine as instructed. If the machine is hand held, do not carry it by the power supply cable. If the product is heavy, employ a second or third person to help move it safely or use a mechanical device. Always refer to the instructions for the correct method.

Do not overreach. Extending your body too far can result in a loss of balance and you falling. This could be from a height or onto a machine and will result in injury.

Maintain your tools correctly. A well maintained tool will do the job safely. Replace any damaged or missing parts immediately with original parts from the manufacturer. As applicable, keep blades sharp, moving parts clean, oiled or greased, handles clean, and emergency devices working.

5. HEALTH AND SAFETY INFORMATION

Wait for the machine to stop. Unless the machine is fitted with a safety brake, some parts may continue to move due to momentum. Wait for all parts to stop, then unplug it from the power supply before making any adjustments, carrying out maintenance operations or just finishing using the tool.

Remove and check setting tools. Some machinery requires the use of additional tools or keys to set, load or adjust the power tool. Before starting the power tool always check to make certain they have been removed and are safely away from the machine.

Prevent unintentional starting. Before plugging any machine in to the power supply, make sure the switch is in the OFF position. If the machine is portable, do not hold the machine near the switch and take care when putting the machine down, that nothing can operate the switch.

Carefully select an extension lead. Some machines are not suitable for use with extension leads. If the tool is designed for use outdoors, use an extension lead also suitable for that environment. When using an extended lead, select one capable of handling the current (amps) drawn by the machine in use. Fully extend the lead regardless of the distance between the power supply and the tool. Excess current (amps) and a coiled extension lead will both cause the cable to heat up and can result in fire.

Concentrate and stay alert. Distractions are likely to cause an accident. Never operate a power tool if you are under the influence of drugs (prescription or otherwise), including alcohol or if you are feeling tired. Being disorientated will result in an accident.

Have this tool repaired by a qualified person. This tool is designed to conform to the relevant international and local standards and as such should be maintained and repaired by someone qualified, using only original parts supplied by the manufacturer. This will ensure the tool remains safe to use.

5.2 SPECIFIC SAFETY INSTRUCTIONS FOR NIBBLERS

NIBBLER SAFETY WARNINGS

1. Hold the tool firmly.
2. Secure the workpiece firmly.
3. Keep hands away from moving parts.
4. Cut edges and the chips that are produced from the workpiece are sharp.
Wear gloves. We also recommended that you put on thickly bottomed shoes and trousers or other garments that cover the top of your shoes to prevent injury.
5. Do not put the tool down on the chips of the workpiece. It can damage the tool.
6. Do not leave the tool running. Operate the tool only when hand-held.
7. Always be sure you have a firm footing.
Be sure no one is below when using the tool in high locations.
8. Do not touch the punch, die or the workpiece immediately after operation; they may be extremely hot and could burn your skin.
9. Avoid cutting electrical wires. It can cause serious accident by electric shock.

SAVE THESE INSTRUCTIONS.

5.3 RESIDUAL RISK

Important note: Although the safety instructions and operating manuals for our tools contain extensive instructions for safe working with power tools, every power tool involves a certain residual risk which can not be completely excluded by safety mechanisms. Power tools must therefore always be operated with caution!

6. TECHNICAL DESCRIPTION

6.1 IDENTIFICATION

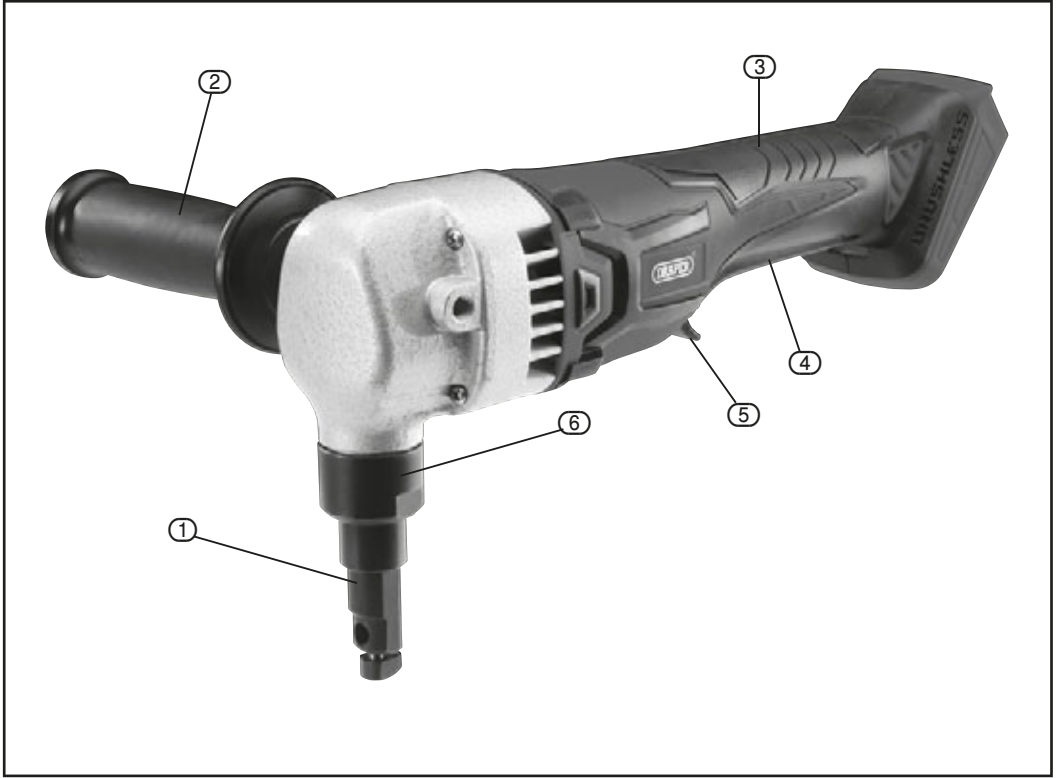

- ① Freehand nibbler head.
- ② Auxiliary handle.
- ③ Soft grip.

- ④ Trigger.
- ⑤ Safety lock.
- ⑥ Lock nut.

7. UNPACKING AND CHECKING

7.1 PACKAGING

Carefully remove the product from the packaging and examine it for any sign of damage that may have happened during shipping. Lay the contents out and check them against the parts shown below. If any part is damaged or missing, please contact the Draper Help Line (the telephone number appears on the Title page) and do not attempt to use the product.

The packaging material should be retained at least during the warranty period, in case the machine needs to be returned for repair.

Warning!

- Some of the packaging materials used may be harmful to children. Do not leave any of these materials in the reach of children.
- If any of the packaging is to be thrown away, make sure they are disposed of correctly, according to local regulations.

7.2 D20 MULTI-TOOL INTERCHANGEABLE BATTERY SYSTEM

The D20 range of tools are a range of tools suitable for enthusiasts and tradespersons alike, featuring a wide array of machines all running from the same range of batteries. Many different capacity batteries are available making sure you can balance tool weight with longevity and find a battery that meets your needs. To find out the latest range of accessories including batteries and chargers please consult the Draper website for more information or to find your local Draper stockist.



7.3 WHAT'S IN THE BOX

As well as the main product, there are also several other parts not fitted or attached to it:

- ⑥ Spanner.
- ⑦ Large hexagon key.
- ⑧ Small hexagon key.

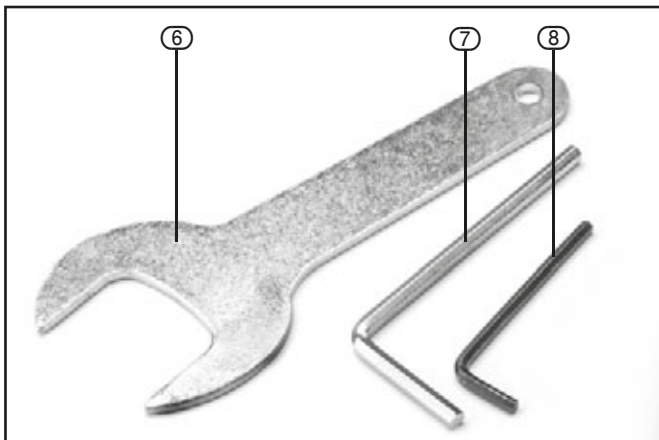

8. PREPARING THE NIBBLER

Note: Remove the battery before carrying out adjustment, servicing or maintenance.

8.1 CUTTING HEAD POSITION AND DIRECTION CHANGING - FIGS. 1 - 4

The freehand nibbler head ① can be rotated for 360°.

- Loosen grub screw using supplied hex. key ⑦ (Fig.1.), rotate head to required position then re-tighten grub screw.

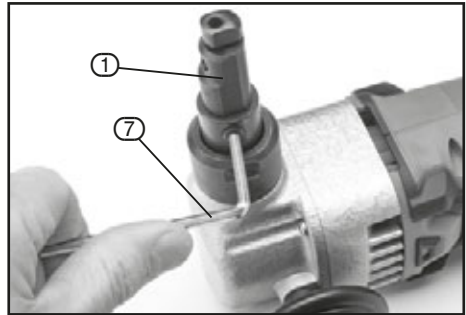

FIG.1

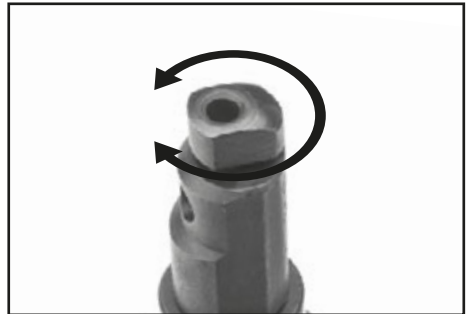

FIG.2

8.2 CUTTING THICKNESS

Cutting thickness depends on material. Cutting head may be damaged if the material is thicker than cutting head insert area.

Ensure the cutting thickness is not more than 1.2mm.



FIG.3

8. PREPARING THE NIBBLER

8.3 SWITCH

The switch has a safety lock to prevent accidental starting, to operate push safety lock upwards towards the head of the machine and pull the on/off switch towards yourself.

Before installing a battery make sure that the safety lock is operating properly and the main switch is inoperable without disengaging the safety lock.

After installing the battery operate the switch and ensure that the machine starts properly and stops when the switch is released.

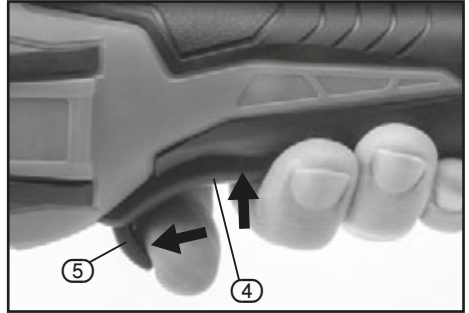

FIG.4

8.4 SUPPORT HANDLE

Screw the axillary handle (2) to M8 threaded hole, turn the handle till the handle tightens and can not moved.

Note: There are holes in left and right side.

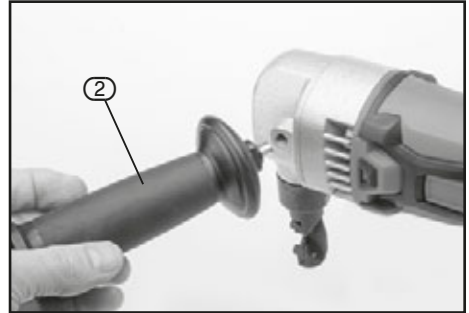

FIG.5

8. PREPARING THE NIBBLER

8.5 REMOVING AND INSTALLING HEADS

To change cutter heads, first undo the lock nut with supplied spanner and continue to loosen until it is free from the threads (Fig.6).

Grasp the cutter head and pull in a perpendicular direction to the body of the tool.

The cutter head should slide out of the tool easily (Fig.7).



FIG.6



FIG.7

8. PREPARING THE NIBBLER

To install a cutter head, the cutter needs to be located in the plunger first, then slide the correct cutter head over the cutter and locate in the tool, this may be tricky at first as the cutter needs to line up accurately to locate the cutter head, it may be easier to allow the cutter to hang from the plunger (Fig.8.) and slide the cutter head into place from underneath with the rapid cutter you may need to slacken the bolts holding the upper guide on to allow it to slide easily into place (Fig.10.). You also need to line up the groove in the cutter with the rear of the cutter head (Figs.9-10). Don't tighten the bolts up too much or you may restrict the removal of the cutter head.

Once the cutter head is fully located rotate the head until it locks into position (the freehand head locks in two positions 180deg apart and the rapid nibbler head locks into 4 positions 90deg apart) once located tighten up the lock nut with the supplied spanner.



FIG.8

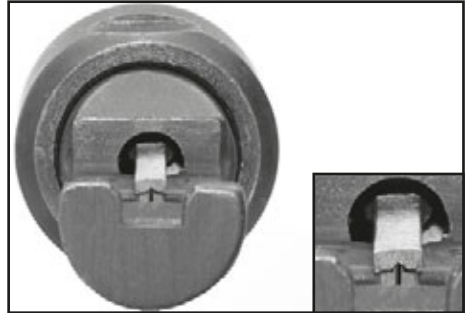

FIG.9



FIG.10

9. BASIC NIBBLER OPERATION

9.1 CUTTING METHOD

Hold the machine 90° to the cutting sheet, move the machine slowly.

When using the rapid nibbler you can cut straight lines and slight curves.

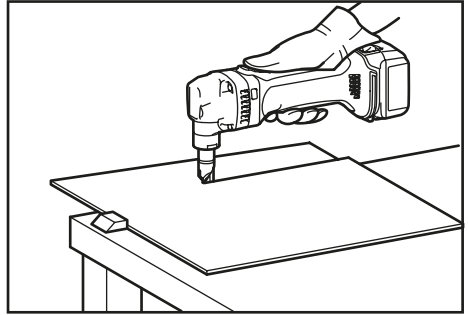

FIG.14

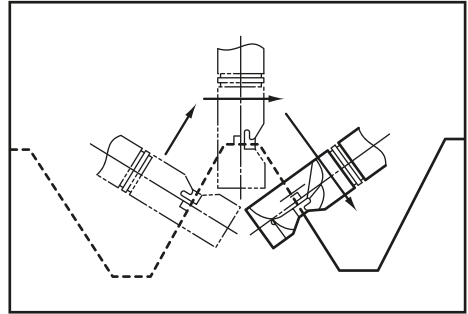

FIG.15

When using the freehand nibbler head you can cut curves down to a radius of 25mm.

If you wish to cut out from the middle of a sheet, you need to drill a hole 16mm or larger to provide clearance for the head to be inserted in the sheet.

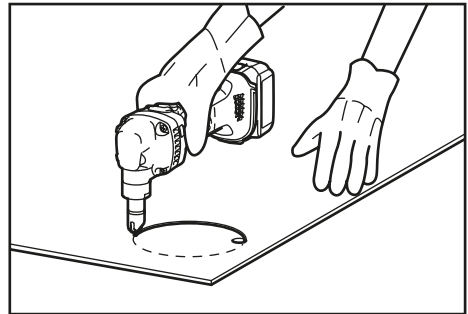

FIG.16

10. MAINTENANCE

10.1 MAINTENANCE

All plastic parts should be cleaned with a soft damp cloth. NEVER use solvents to clean plastic parts, because these can cause damage to the item.

If anything unusual happens during use of the item then turn the item off and check the item thoroughly. If necessary have the machine repaired by a qualified technician before using it again.

All repairs should be carried out by a qualified technician. Repair or maintenance undertaken by unqualified persons can cause risk of injury or damage.

Use only original parts for the repair of this tool.

11. OPTIONAL ACCESSORIES

11.1 OPTIONAL ACCESSORIES

A full range of accessories are available from Draper Tools.

Please visit our website for details: www.drapertools.com

12. DISPOSAL

12.1 DISPOSAL

- At the end of the machine's working life, or when it can no longer be repaired, ensure that it is disposed of according to national regulations.
- Contact your local authority for details of collection schemes in your area.

In all circumstances:

- Do not dispose of power tools with domestic waste.
- Do not incinerate.
- Do not dispose of WEEE* as unsorted municipal waste.



* *Waste Electrical & Electronic Equipment.*

13. EXPLANATION OF SYMBOLS

13.1 EXPLANATION OF SYMBOLS



Read the instruction manual.



Wear safety glasses and dust mask.



Wear ear defenders.



Wear protective gloves.



Long and loose hair must be contained or securely tied back.



Keep out of the reach of children.



Warning!



Class II construction.
(Double insulated).



WEEE –
Waste Electrical &
Electronic Equipment.
*Do not dispose of Waste Electrical
& Electronic Equipment in with
domestic rubbish.*

CONTACTS

Draper Tools Limited, Hursley Road,
Chandler's Ford, Eastleigh, Hampshire. SO53 1YF. U.K.

Help line: (023) 8049 4344

Sales Desk: (023) 8049 4333

Internet: drapertools.com

E-mail: sales@drapertools.com

General Enquiries: (023) 8026 6355

Service/Warranty Repair Agent:

For aftersales servicing or warranty repairs, please contact the
Draper Tools Help line for details of an agent in your local area.

YOUR DRAPER STOCKIST

TAKC0119

©Published by Draper Tools Limited.

No part of this publication may be reproduced, stored in a retrieval system or transmitted in any form or by any means, electronic, mechanical photocopying, recording or otherwise without prior permission in writing from Draper Tools Ltd.