



**DRAPER**<sup>®</sup>

230V 165mm

# PLUNGE SAW

57341



These instructions accompanying the product are the original instructions. This document is part of the product, keep it for the life of the product passing it on to any subsequent holder of the product. Read all these instructions before assembling, operating or maintaining this product.

This manual has been compiled by Draper Tools describing the purpose for which the product has been designed, and contains all the necessary information to ensure its correct and safe use. By following all the general safety instructions contained in this manual, it will ensure both product and operator safety, together with longer life of the product itself.

All photographs and drawings in this manual are supplied by Draper Tools to help illustrate the operation of the product.

Whilst every effort has been made to ensure the accuracy of information contained in this manual, the Draper Tools policy of continuous improvement determines the right to make modifications without prior warning.

# 1. TITLE PAGE

---

## 1.1 INTRODUCTION:

USER MANUAL FOR: 230V 165mm Plunge Saw

Stock No: 57341

Part No: PS1200D

## 1.2 REVISIONS:

Date first published September 2018.

---

---

---

---

As our user manuals are continually updated, users should make sure that they use the very latest version.

**Downloads are available from:** <http://drapertools.com/manuals>

Draper Tools Limited

Hursley Road

Chandler's Ford

Eastleigh

Hampshire

SO53 1YF

UK

**Website:** [drapertools.com](http://drapertools.com)

**Product help line:** +44 (0) 23 8049 4344

**General Fax:** +44 (0) 23 8026 0784

## 1.3 UNDERSTANDING THIS MANUALS SAFETY CONTENT:

**WARNING!** – Information that draws attention to the risk of injury or death.

**CAUTION!** – Information that draws attention to the risk of damage to the product or surroundings.

## 1.4 COPYRIGHT © NOTICE:

Copyright © Draper Tools Limited.

Permission is granted to reproduce this publication for personal and educational use only. Commercial copying, redistribution, hiring or lending is prohibited.

No part of this publication may be stored in a retrieval system or transmitted in any other form or means without written permission from Draper Tools Limited.

In all cases this copyright notice must remain intact.

---

## 2. CONTENTS

---

<b>1. TITLE PAGE</b>	
1.1 INTRODUCTION.....	2
1.2 REVISION HISTORY .....	2
1.3 UNDERSTANDING THIS MANUAL .....	2
1.4 COPYRIGHT NOTICE .....	2
<b>2. CONTENTS</b>	
2.1 CONTENTS.....	3
<b>3. WARRANTY</b>	
3.1 WARRANTY.....	4
<b>4. INTRODUCTION</b>	
4.1 SCOPE.....	5
4.2 SPECIFICATION .....	5
4.3 HANDLING AND STORAGE.....	6
<b>5. HEALTH AND SAFETY INFORMATION</b>	
5.1 GENERAL SAFETY INSTRUCTIONS FOR POWER TOOL USE .....	6
5.2 GENERAL SAFETY INSTRUCTIONS FOR ALL SAWS .....	7
5.3 GENERAL SAFETY INSTRUCTIONS FOR PLUNGE SAWS.....	8
5.4 RESIDUAL RISK.....	8
5.5 CONNECTION TO THE POWER SUPPLY.....	9
<b>6. TECHNICAL DESCRIPTION</b>	
6.1 IDENTIFICATION .....	10
<b>7. UNPACKING AND CHECKING</b>	
7.1 PACKAGING .....	11
7.2 WHAT'S IN THE BOX.....	11
<b>8. PREPARING THE PLUNGE SAW</b>	
8.1 BLADE REPLACEMENT AND INSTALLATION .....	12
8.2 CONNECTING THE RAIL .....	12
<b>9. BASIC PLUNGE SAW OPERATIONS</b>	
9.1 ON/OFF TRIGGER SWITCH .....	13
9.2 DUST EXTRACTION .....	13
9.3 CUTTING DEPTH ADJUSTMENT .....	13
9.4 CUTTING ANGLE ADJUSTMENT .....	13
9.5 CUT INDICATORS .....	13
9.6 GUIDE RAIL ADJUSTMENT .....	14
9.7 SAW OPERATION .....	14
9.8 CUTTING WITH RAILS .....	14
<b>10. MAINTENANCE AND TROUBLESHOOTING</b>	
10.1 CLEANING .....	15
10.2 MAINTENANCE .....	15
10.3 REPAIRS.....	15
10.4 TROUBLESHOOTING .....	15
<b>11. OPTIONAL ACCESSORIES</b>	
11.1 OPTIONAL ACCESSORIES.....	16
<b>12. DISPOSAL</b>	
12.1 DISPOSAL.....	17
<b>13. EXPLANATION OF SYMBOLS</b>	
13.1 EXPLANATION OF SYMBOLS .....	18
<b>DECLARATION OF CONFORMITY .....</b>	<b>ENCLOSED</b>

## 3. WARRANTY

---

### 3.1 WARRANTY

Draper tools have been carefully tested and inspected before shipment and are guaranteed to be free from defective materials and workmanship.

Should the tool develop a fault, please return the complete tool to your nearest distributor or contact

**Draper Tools Limited, Chandler's Ford, Eastleigh, Hampshire, SO53 1YF. England.**

**Telephone Sales Desk: (023) 8049 4333 or Product Help Line (023) 8049 4344.**

A proof of purchase must be provided with the tool.

If upon inspection it is found that the fault occurring is due to defective materials or workmanship, repairs will be carried out free of charge. This guarantee period covering labour is 12 months from the date of purchase except where tools are hired out when the guarantee period is 90 days from the date of purchase. The guarantee is extended to 24 months for parts only. This guarantee does not apply to any consumable parts, any type of battery or normal wear and tear, nor does it cover any damage caused by misuse, careless or unsafe handling, alterations, accidents, or repairs attempted or made by any personnel other than the authorised Draper warranty repair agent.

Note: If the tool is found not to be within the terms of warranty, repairs and carriage charges will be quoted and made accordingly.

This guarantee applies in lieu of any other guarantee expressed or implied and variations of its terms are not authorised.

Your Draper guarantee is not effective unless you can produce upon request a dated receipt or invoice to verify your proof of purchase within the guarantee period.

Please note that this guarantee is an additional benefit and does not affect your statutory rights.

**Draper Tools Limited.**

# 4. INTRODUCTION

---

## 4.1 SCOPE

As part of our core range, this product is suitable for enthusiasts and tradespeople alike. Any application other than that it was intended for, is considered misuse.

## 4.2 SPECIFICATION

Stock No.....	57341
Part No. ....	PS1200D
Rated voltage .....	230V~50Hz
Rated input.....	1200W
Speed (no load).....	5200r/min
Cutting angle .....	0 – 45°
Cutting depth .....	56mm at 90°
.....	40mm at 45°
BladeØ .....	165mm
Sound pressure level (LpA)*: .....	94dB(A)
Sound power level (LWA)**: .....	105dB(A)
Uncertainty (K): .....	3dB(A)
Vibration level†:.....	3m/s <sup>2</sup> , K=1.5m/s <sup>2</sup>
Weight .....	4.7kg
Cable length .....	2.0M

\* *Continuous A-Weighted Sound Pressure Level at the workstation in accordance to and declared according to EN60745.*

\*\* *The typical A-weighted noise level determined according to EN60745.*

† *When sawing in wood.*

## 4.3 HANDLING & STORAGE

- Care must be taken when handling this product.
  - Dropping this power tool could have an effect on its accuracy and could also result in personal injury. This product is not a toy and must be respected.
- Environmental conditions can have a detrimental effect on this product if neglected.
  - Exposure to damp air can gradually corrode components.
  - If the product is unprotected from dust and debris, components will become clogged.
  - If not cleaned and maintained correctly or regularly, the machine will not perform at its best.

## 5. HEALTH AND SAFETY INFORMATION

---

### 5.1 GENERAL SAFETY INSTRUCTIONS FOR POWER TOOL USE

When using any type of power tool there are steps that should be taken to make sure that you, as the user, remain safe.

Common sense and a respect for the tool will help reduce the risk of injury.

**Read the instruction manual fully.** Do not attempt any operation until you have read and understood this manual.

Most important you must know how to safely start and stop this machine, especially in an emergency.

**Keep the work area tidy and clean.** Attempting to clear clutter from around the machine during use will reduce your concentration. Mess on the floor creates a trip hazard. Any liquid spill on the floor could result in you slipping.

**Find a suitable location.** If the machine is bench mounted, the location should provide good natural light or artificial lighting as a replacement. Avoid damp and dust locations as it will have a negative effect on the machine's performance. If the machine is portable do not expose the tool to rain. In all cases do not operate power tools near any flammable materials.

**Keep bystanders away.** Children, onlookers and passers by must be restricted from entering the work area for their own protection. The barrier must extend a suitable distance from the tool user.

**Unplug and house all power tools that are not in use.** A power tool should never be left unattended while connected to the power supply. They must be housed in a suitable location, away locked up and from children. This includes battery chargers.

**Do not overload or misuse the tool.** All tools are designed for a purpose and are limited to what they are capable of doing. Do not attempt to use a power tool (or adapt it in any way) for an application it is not designed for. Select a tool appropriate for the size of the job. Overloading a tool will result in tool failure and user injury. This covers the use of accessories.

**Dress properly.** Loose clothing, long hair and jewellery are all dangerous because they can become entangled in moving machinery. This can also result in parts of body being pulled into the machine. Clothing should be close fitted, with any long hair tied back and jewellery and neck ties removed. Footwear must be fully enclosed and have a non-slip sole.

**Wear personal protective equipment (PPE).** Dust, noise, vibration and swarf can all be dangerous if not suitably protected against. If the work involving the power tool creates dust or fumes wear a dust mask. Vibration to the hand, caused by operating some tools for longer periods must be protected against. Wear vibration reducing gloves and allow long breaks between uses. Protect against dust and swarf by wearing approved safety goggles or a face shield. These are some of the more common hazards and preventions, however, always find out what hazards are associated with the machine/work process and wear the most suitable protective equipment available.

**Do not breathe contaminated air.** If the work creates dust or fumes connect the machine (if possible) to an extraction system either locally or remotely. Working outdoors can also help if possible.

**Move the machine as instructed.** If the machine is hand held, do not carry it by the power supply cable. If the product is heavy, employ a second or third person to help move it safely or use a mechanical device. Always refer to the instructions for the correct method.

**Do not overreach.** Extending your body too far can result in a loss of balance and you falling. This could be from a height or onto a machine and will result in injury.

**Maintain your tools correctly.** A well maintained tool will do the job safely. Replace any damaged or missing parts immediately with original parts from the manufacturer. As applicable, keep blades sharp, moving parts clean, oiled or greased, handles clean, and emergency devices working.

**Wait for the machine to stop.** Unless the machine is fitted with a safety brake, some parts may continue to move due to momentum. Wait for all parts to stop, then unplug it from the power supply before making any adjustments, carrying out maintenance operations or just finishing using the tool.

## 5. HEALTH AND SAFETY INFORMATION

---

**Remove and check setting tools.** Some machinery requires the use of additional tools or keys to set, load or adjust the power tool. Before starting the power tool always check to make certain they have been removed and are safely away from the machine.

**Prevent unintentional starting.** Before plugging any machine in to the power supply, make sure the switch is in the OFF position. If the machine is portable, do not hold the machine near the switch and take care when putting the machine down, that nothing can operate the switch.

**Carefully select an extension lead.** Some machines are not suitable for use with extension leads. If the tool is designed for use outdoors, use an extension lead also suitable for that environment. When using an extended lead, select one capable of handling the current (amps) drawn by the machine in use. Fully extend the lead regardless of the distance between the power supply and the tool. Excess current (amps) and a coiled extension lead will both cause the cable to heat up and can result in fire.

**Concentrate and stay alert.** Distractions are likely to cause an accident. Never operate a power tool if you are under the influence of drugs (prescription or otherwise), including alcohol or if you are feeling tired. Being disorientated will result in an accident.

**Have this tool repaired by a qualified person.** This tool is designed to conform to the relevant international and local standards and as such should be maintained and repaired by someone qualified, using only original parts supplied by the manufacturer. This will ensure the tool remains safe to use.

### 5.2 ADDITIONAL SAFETY INSTRUCTIONS FOR ALL SAWS

**Keep hands away from cutting area and the blade.** Keep your second hand on the auxiliary handle, or motor housing. If both hands are holding the saw, they cannot be cut by the blade.

**Do not reach underneath the workpiece.** The guard cannot protect you from the blade below the workpiece.

**Adjust the cutting depth to the thickness of the workpiece.** Less than a full tooth of the blade teeth should be visible below the workpiece.

**Never hold piece being cut in your hands or across your leg.** Secure the workpiece to a stable platform. It is important to support the work properly to minimise body exposure, blade binding or loss of control.

**Hold power tool by insulated gripping surfaces when performing an operation where the cutting tool may contact hidden wiring or its own cord.** Contact with a “live” wire will also make exposed metal parts of the power tool “live” and shock the operator.

**When ripping always use a rip fence or straight edge guide.** This improves the accuracy of cut and reduces chance of blade binding.

**Always use blade with correct size and shape (diamond versus round) of arbour holes.** Blades that do not match the mounting hardware of the saw will run eccentrically, causing loss of control.

**Never use damaged or incorrect blade washers or bolt.** The blade washers and bolt were specially designed for your saw, for optimum performance and safety of operation.

#### **Causes and operator prevention of kickback:**

- Kickback is a sudden reaction to a pinched, bound or misaligned saw blade, causing an uncontrolled saw to lift up and out of the workpiece towards the operator.
- When the blade is pinched or bound tightly by the kerf closing down, the blade stalls and the motor reaction drives the unit rapidly back towards the operator.
- If the blade becomes twisted or misaligned in the cut, the teeth at the back edge of the blade can dig into the top surface of the wood causing the blade to climb out of the kerf and jump back toward the operator.
- Kickback is the result of saw misuse and/or incorrect operating procedures or conditions and can be avoided by taking proper precautions as given below.

## 5. HEALTH AND SAFETY INFORMATION

---

- Maintain a firm grip with both hands on the saw and position your arms to resist kickback forces. Position your body to either side of the blade, but not in line with the blade. Kickback could cause the saw to jump backwards, but kickback forces can be controlled by the operator, if proper precautions are taken.
- When blade is binding, or when interrupting a cut for any reason, release the trigger and hold the saw motionless in the material until the blade comes to a complete stop. Never attempt to remove the saw from the work or pull the saw backward while the blade is in motion or kickback may occur. Investigate and take corrective actions to eliminate the cause of blade binding.
- When restarting a saw in the workpiece, centre the saw blade in the kerf and check that saw teeth are not engaged into the material. If saw blade is binding, it may walk up or kickback from the workpiece as the saw is restarted.
- Support large panels to minimise the risk of blade pinching and kickback. Large panels tend to sag under their own weight. Supports must be placed under the panel on both sides, near the line of cut and near the edge of the panel.
- Do not use dull or damaged blades. Unsharpened or improperly set blades produce narrow kerf causing excessive friction, blade binding and kickback.
- Blade depth and bevel adjusting locking levers must be tight and secure before making cut. If blade adjustment shifts while cutting, it may cause binding and kickback.
- Use extra caution when making a “plunge cut” into existing walls or other blind areas. The protruding blade may cut objects that can cause kickback.

### 5.3 GENERAL SAFETY INSTRUCTIONS FOR PLUNGE SAWS

**Check guard for proper closing before each use.** Do not operate the saw if guard does not move freely and enclose the blade instantly. Never clamp or tie the guard with the blade exposed. If saw is accidentally dropped, guard may be bent. Check to make sure that guard moves freely and does not touch the blade or any other part, in all angles and depths of cut.

**Check the operation and condition of the guard return spring.** If the guard and the spring are not operating properly, they must be serviced before use. Guard may operate sluggishly due to damaged parts, gummy deposits, or a build-up of debris.

**Assure that the guide plate of the saw will not shift while performing the “plunge cut” when the bevel setting is not at 90°.** Blade shift sideways will cause binding and likely kick back.

**Always observe that the guard is covering the blade before placing saw down on bench or floor.** An unprotected, coasting blade will cause the saw to walk backwards, cutting whatever is in its path. Be aware of the time it takes for the blade to stop after switch is released.

**Do not unnecessarily burden the machine.** Excessive pressure when cutting will damage the blade quickly. This leads to a reduction in performance of the machine in the processing and in the cutting accuracy.

### 5.4 RESIDUAL RISK

**Important note:** Although the safety instructions and operating manuals for our tools contain extensive instructions for safe working with power tools, every power tool involves a certain residual risk which can not be completely excluded by safety mechanisms. Power tools must therefore always be operated with caution!



## 5. HEALTH AND SAFETY INFORMATION

---

### 5.5 CONNECTION TO THE POWER SUPPLY

**Caution:** Risk of electric shock. Do not open.

This appliance is supplied with a moulded 3 pin mains plug for your safety. The value of the fuse fitted is marked on the pin face of the plug. Should the fuse need replacing, ensure the substitute is of the correct rating, approved to BS1362 and ASTA or BSI Kite marked.

ASTA 

BSI 

The fuse cover is removable with a small plain slot screwdriver. Ensure the fuse cover is replaced before attempting to connect the plug to an electrical outlet. If the cover is missing, a replacement must be obtained or the plug replaced with a suitable type.

If a replacement plug is to be fitted this must be carried out by a qualified electrician.

The damaged or incomplete plug, when cut from the cable should be disabled to prevent connection to a live electrical outlet.

This appliance is Class II<sup>†</sup> and is designed for connection to a power supply matching that detailed on the rating label and compatible with the plug fitted.

If an extension lead is required, use an approved and compatible lead rated for this appliance. Follow all the instructions supplied with the extension lead.

<sup>†</sup>*Double insulated* : *This product requires no earth connection as supplementary insulation is applied to the basic insulation to protect against electric shock in the event of failure of the basic insulation.*

#### IMPORTANT

**If using an extension lead, follow the instructions that came with your lead regarding maximum load while cable is wound. If in doubt, ensure that the entire cable is unwound. Using a coiled extension lead will generate heat which could melt the lead and cause a fire.**

## 6. TECHNICAL DESCRIPTION

### 6.1 IDENTIFICATION

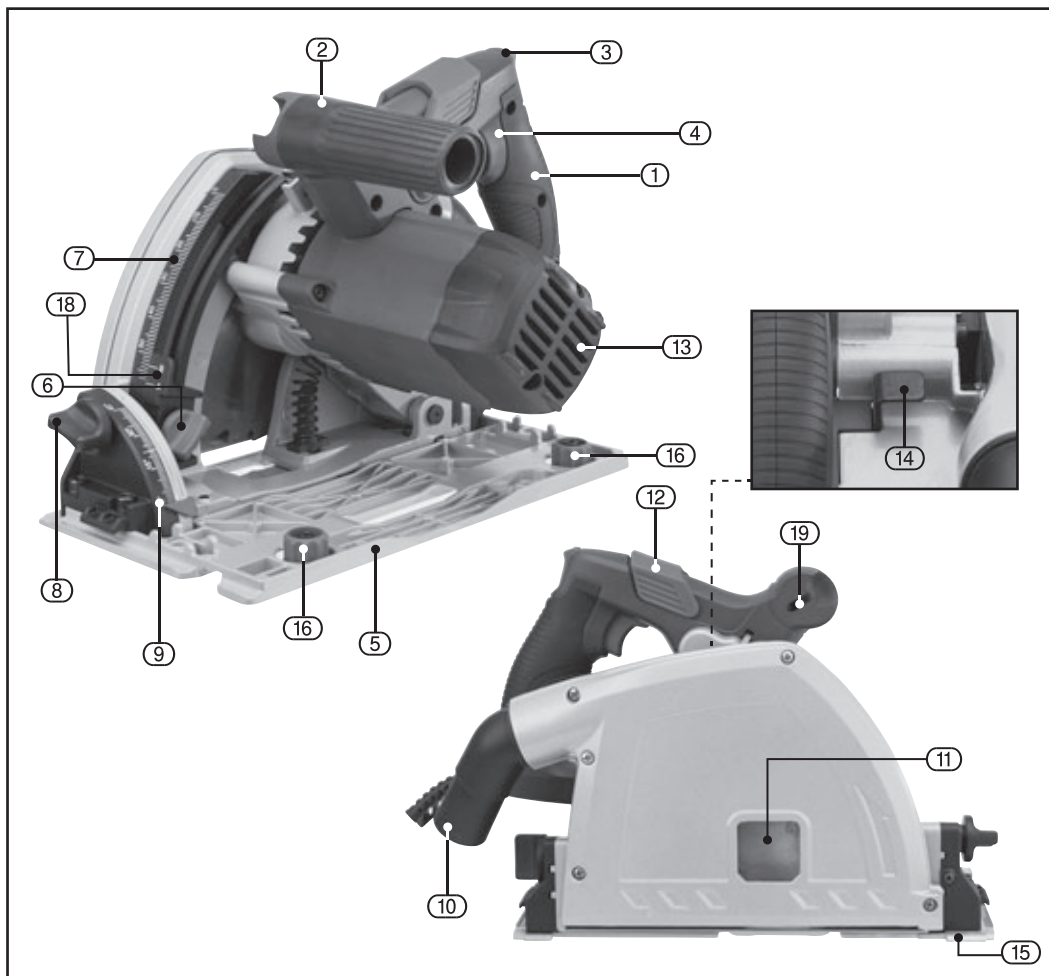

- ① Main handle.
- ② Front handle.
- ③ Safety button.
- ④ On/off switch.
- ⑤ Base plate.
- ⑥ Adjusting knob for cutting depth.
- ⑦ Scale for cutting depth.
- ⑧ Adjusting knob for cutting angle.
- ⑨ Scale for cutting angle.
- ⑩ Dust extraction tube.
- ⑪ Saw blade.
- ⑫ Blade change locking lever.
- ⑬ Motor.
- ⑭ Shaft locking button.
- ⑮ Cut indicator.
- ⑯ Adjusting knob for rail.
- ⑰ Hex. key (5mm).
- ⑱ Cutting depth indicators.
- ⑲ Hex. key (3mm).

# 7. UNPACKING AND CHECKING

---

## 7.1 PACKAGING

Carefully remove the product from the packaging and examine it for any sign of damage that may have happened during shipping. Lay the contents out and check them against the parts shown below. If any part is damaged or missing, please contact the Draper Help Line (the telephone number appears on the Title page) and do not attempt to use the product.

The packaging material should be retained at least during the guarantee period: in case the machine needs to be returned for repair.

### Warning!

- Some of the packaging materials used may be harmful to children. Do not leave any of these materials in the reach of children.
- If any of the packaging is to be thrown away, make sure they are disposed of correctly, according to local regulations.

## 7.2 WHAT'S IN THE BOX

As well as the main product, there are also several other parts not fitted or attached to it:

(20) Rails x2.

(21) Blade.

(22) Hex. keys x2.

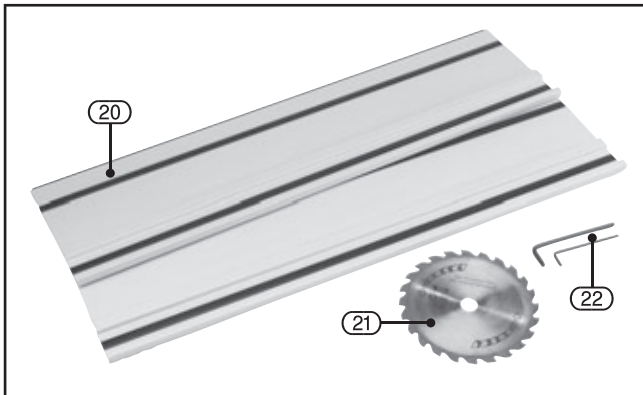

## 8. PREPARING THE PLUNGE SAW

**Warning!** Before changing the saw blade, switch off the machine and unplug the power cord.

### 8.1 BLADE REPLACEMENT AND INSTALLATION – FIGS.1 – 3

- Push the safety switch and press the handle down.
- Push the locking lever (12) forward. Release the switch lock (3). The motor unit will lock into place.
- Push the spindle lock (14) and use the hex key (17) to undo the clamping screw anti-clockwise.
- Remove the washer from the saw blade (11).
- Install the new blade (11) in the respective reverse order.

**Caution:** Risk of injuries, wear protective gloves.

- Insert the new blade and flange.
- Screw in and tighten the saw blade locking screw while keeping the shaft locking button pressed again.
- Set the plunge saw to its original position.

### 8.2 CONNECTING THE RAIL – FIG.4

- The rail (20) is used to make straight cuts. To connect the two rails, slide the fastener into the notch on the guide tracks. Tighten the set screws (23) with the included hex key (22).

**Note:** Rail (20) features a splinter guard (black rubber lip). The splinter guard must be adjusted before making the first cut.

Place the rail (20) on a work piece. Set to a cutting depth of approx. 10mm. Switch on the plunge saw and steadily guide it in the direction of the cut, pushing slightly. This cuts off the guard perfectly in line with the cut ensuring that set-up for future cuts is easy.

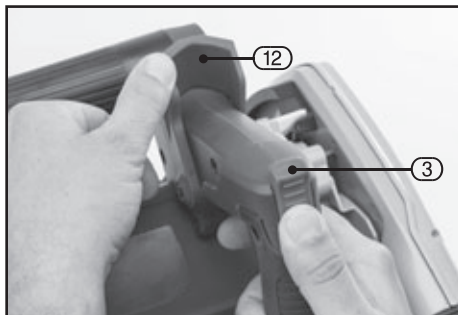

FIG.1

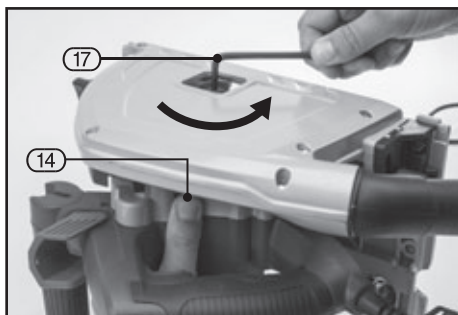

FIG.2

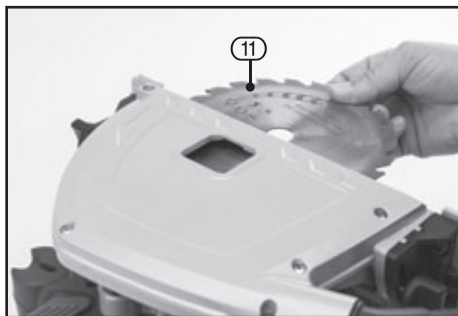

FIG.3

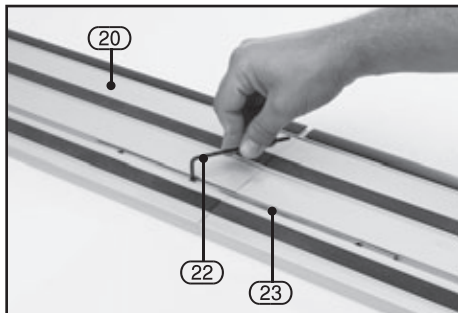

FIG.4

## 9. BASIC PLUNGE SAW OPERATIONS

### 9.1 ON/OFF TRIGGER SWITCH – FIG.5

The on/off switch (4) is operated in conjunction with a safety release button (3) so that it is not possible to start the saw by accident.

- To start the saw, press the safety button (3) first and then press the on/off switch (4).
- To switch off, release the on/off switch (4).

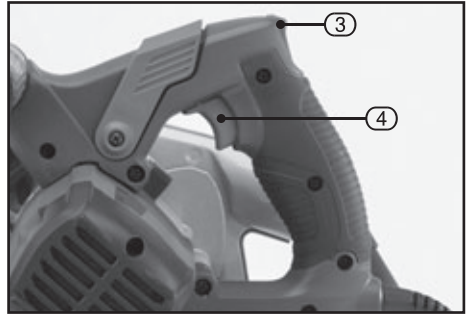

FIG.5

### 9.2 DUST EXTRACTION – FIG.6

Inhalation of dust particles can be detrimental to health. The dust outlet (10) must be connected with a dust extraction machine.

**Warning!** All wood dust (including dust from composites like chipboards and fibre boards etc.) is hazardous to health. It can affect the nose, the respiratory system and the skin. For example MDF (medium density fibreboard) which contains formaldehyde is a known carcinogen. In addition to the above measures a correctly fitted dust mask, suitable for the activity and in accordance to the relevant standard, must be worn.

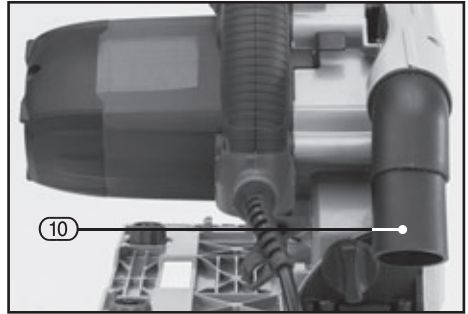

FIG.6

### 9.3 CUTTING DEPTH ADJUSTMENT – FIG.7

- The cutting depth can be adjusted from 0 – 56mm.
- Unfasten the cutting depth adjustment knob (6) and set the required depth using the scale (7) and retighten the knob.

The markers on the dimension scale show marks for depth with (A) and without (B) the guide rail.

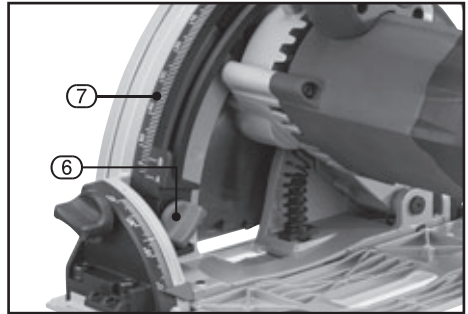

FIG.7

### 9.4 CUTTING ANGLE ADJUSTMENT – FIG.8

The angle can be altered between 0° to 45°.

- Unfasten the angle adjustment knob (8) on both sides, set the desired angle on the scale (9) and retighten the knob.

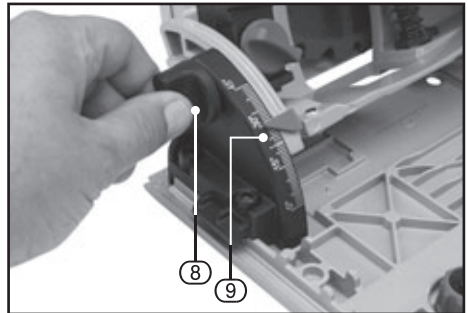

FIG.8

### 9.5 CUT INDICATORS

- The cutting line should be aligned with the 0° marker arrow when performing a cut at 0°.
- The cutting line should be aligned with the 45° marker arrow when performing a cut at 45°.

## 9. BASIC PLUNGE SAW OPERATIONS

### 9.6 GUIDE RAIL ADJUSTMENT – FIG.9

- Tighten the adjusting knob (16) to minimize the clearance between the saw and the rail.

### 9.7 SAW OPERATION

- Secure the work piece so that it cannot get displaced or moved while sawing.
- Only move the saw forwards.
- Grip the saw tightly with both hands ensuring that one hand is placed on the main handle and the other on the front handle.
- When using a guide rail, it must be fastened with screw clamps.
- Make sure the power cable is not placed in the sawing direction.
- Place the front part of the machine onto the work piece.
- Switch the machine on using the on/off switch.
- Push the saw downwards to reach the cut depth.
- Push the saw forward evenly.
- After finishing the sawing cut, switch the machine off and move the saw blade upwards.

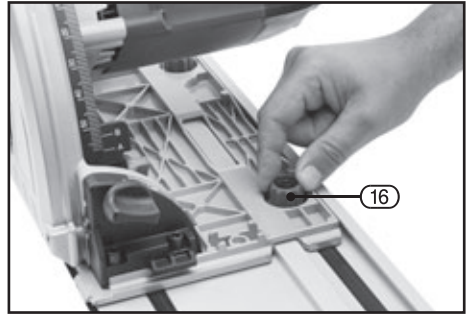

FIG.9

### 9.8 CUTTING WITH RAILS

- Place the machine in the guide rails. Turn the machine on by pressing the on/off switch.
- Press the saw downwards to reach the sawing depth. During first use the rubber lip is sawn off and thus splinter protection is guaranteed up to the saw blade.
- Push the saw uniformly forwards.
- Turn off the machine and tilt the saw blade to the top when the saw cutting is complete.

# 10. MAINTENANCE AND TROUBLESHOOTING

---

## 10.1 CLEANING

Keep all safety devices, air vents and the motor housing free of dirt and dust as far as possible. Wipe the equipment with a clean cloth or blow it with compressed air at low pressure.

We recommend that you clean the device immediately each time you have finished using it.

Clean the equipment regularly with a moist cloth and some soft soap. Do not use cleaning agents or solvents; these could attack the plastic parts of the equipment. Ensure that no water can seep into the device.

## 10.2 MAINTENANCE

There are no parts inside the equipment which require additional maintenance.

## 10.3 REPAIRS

Only use accessories and spare parts recommended by the manufacturer. If the equipment should fail some day in spite of our quality controls and your maintenance, only have it repaired by an authorized electrician.

If the supply cord of the appliance is damaged, this has to be done by the manufacturer or his agent or electrician in order to avoid a safety hazard.

## 10.4 TROUBLESHOOTING

<b>Problem</b>	<b>Possible Cause</b>	<b>Remedy</b>
Motor does not run.	Faulty motor, power supply cable or plug. Worn brushes	Check the fuse and replace if necessary. Have brushes replaced at service centre.
Saw cut is rough or wavy	The saw blade is dull; the tooth shape is not suited to the thickness of the material.	Re-sharpen the saw blade or use an appropriate saw blade.
Work piece rips or splinters.	The cutting pressure is excessive or the saw blade is not suited to the application.	Use the correct saw blade.

# 11. OPTIONAL ACCESSORIES

---

## 11.1 OPTIONAL ACCESSORIES

A full range of accessories are available from Draper Tools.

Please visit our website for details: [www.drapertools.com](http://www.drapertools.com)



# 12. DISPOSAL

---

## 12.1 DISPOSAL

- At the end of the machine's working life, or when it can no longer be repaired, ensure that it is disposed of according to national regulations.
- Contact your local authority for details of collection schemes in your area.

In all circumstances:

- Do not dispose of power tools with domestic waste.
- Do not incinerate.
- Do not dispose of WEEE\* as unsorted municipal waste.



\* *Waste Electrical & Electronic Equipment.*

# 13. EXPLANATION OF SYMBOLS

---

## 13.1 EXPLANATION OF SYMBOLS



Read the instruction manual.



Wear face mask and safety glasses.



Wear ear defenders.



Wear protective gloves.



Do not abandon into the environment.



Keep out of the reach of children.



**Warning!**



Class II construction  
*(Double insulated).*



WEEE –  
Waste Electrical &  
Electronic Equipment.  
*Do not dispose of Waste Electrical  
& Electronic Equipment in with  
domestic rubbish.*

# NOTES

---

## CONTACTS

Draper Tools Limited, Hursley Road,  
Chandler's Ford, Eastleigh, Hampshire. SO53 1YF. U.K.

Help line: (023) 8049 4344

Sales Desk: (023) 8049 4333

Internet: [drapertools.com](http://drapertools.com)

E-mail: [sales@drapertools.com](mailto:sales@drapertools.com)

General Enquiries: (023) 8026 6355

Service/Warranty Repair Agent:

For aftersales servicing or warranty repairs, please contact the Draper Tools Help line for details of an agent in your local area.

YOUR DRAPER STOCKIST

TACM0918

©Published by Draper Tools Limited.

No part of this publication may be reproduced, stored in a retrieval system or transmitted in any form or by any means, electronic, mechanical photocopying, recording or otherwise without prior permission in writing from Draper Tools Ltd.