

DRAPER®

®

INSTRUCTIONS FOR 750W Dust Extractor

Stock No.79359 Part No.DE750A

IMPORTANT: PLEASE READ THESE INSTRUCTIONS CAREFULLY TO ENSURE THE SAFE AND EFFECTIVE USE OF THIS PRODUCT.



CE

DRAPER®

GENERAL INFORMATION

These instructions accompanying the product are the original instructions. This document is part of the product, keep it for the life of the product passing it on to any subsequent holder of the product. Read all these instructions before assembling, operating or maintaining this product.

This manual has been compiled by Draper Tools describing the purpose for which the product has been designed, and contains all the necessary information to ensure its correct and safe use. By following all the general safety instructions contained in this manual, it will ensure both product and operator safety, together with longer life of the product itself.

All photographs and drawings in this manual are supplied by Draper Tools to help illustrate the operation of the product. Whilst every effort has been made to ensure the accuracy of information contained in this manual, the Draper Tools policy of continuous improvement determines the right to make modifications without prior warning.

1. TITLE PAGE

1.1 INTRODUCTION:

USER MANUAL FOR:

750W DUST EXTRACTOR

Stock no. 79359.

Part no. DE750A.

1.2 REVISIONS:

Date first published February 2015

As our user manuals are continually updated, users should make sure that they use the very latest version.

Downloads are available from: <http://www.drapertools.com/b2c/b2cmanuals.pgm>

DRAPER TOOLS LIMITED

HURSLEY ROAD

CHANDLER'S FORD

EASTLEIGH

HAMPSHIRE

SO53 1YF

UK

WEBSITE: drapertools.com

PRODUCT HELPLINE: +44 (0) 23 8049 4344

GENERAL FAX: +44 (0) 23 8026 0784

1.3 UNDERSTANDING THIS MANUALS SAFETY CONTENT:

WARNING! Information that draws attention to the risk of injury or death.

CAUTION! Information that draws attention to the risk of damage to the product or surroundings.

1.4 COPYRIGHT © NOTICE:

Copyright © Draper Tools Limited.

Permission is granted to reproduce this publication for personal & educational use only.

Commercial copying, redistribution, hiring or lending is prohibited.

No part of this publication may be stored in a retrieval system or transmitted in any other form or means without written permission from Draper Tools Limited.

In all cases this copyright notice must remain intact.

2. CONTENTS

2.1 CONTENTS

<i>Page content</i>	<i>Page</i>
1 TITLE PAGE	
1.1 INTRODUCTION	2
1.2 REVISION HISTORY.....	2
1.3 UNDERSTANDING THIS MANUAL	2
1.4 COPYRIGHT NOTICE	2
2 CONTENTS	
2.1 CONTENTS	3
3 GUARANTEE	
3.1 GUARANTEE	4
4 INTRODUCTION	
4.1 SPECIFICATION	5
4.2 HANDLING & STORAGE	5
5 HEALTH & SAFETY INFORMATION	
5.1 GENERAL SAFETY INSTRUCTIONS FOR POWER TOOL USE	6
5.2 ADDITIONAL SAFETY INSTRUCTIONS FOR DUST EXTRACTORS.....	7A
5.3 CONNECTION TO THE POWER SUPPLY	7B
6 TECHNICAL DESCRIPTION	
6.1 IDENTIFICATION	8B
7 UNPACKING & CHECKING	
7.1 PACKAGING.....	8A
7.2 WHAT'S IN THE BOX?	8A
8 PREPARING THE DUST EXTRACTOR	
8.1 CASTORS.....	9
8.2 MOTOR/DUCTING UNIT & COLLECTION BAG DUCTING.....	9
8.3 UPRIGHT SUPPORTS	9
8.4 ASSEMBLY TO BASE	10
8.5 UPPER BAG HOOK.....	10
8.6 UPPER AND LOWER BAGS	10
8.7 COLLECTION HOSE & FLOOR ATTACHMENT.....	10
9 OPERATING INSTRUCTIONS	
9.1 NO-VOLT ON/OFF SWITCH.....	11
9.2 EMPTYING THE COLLECTION BAG	11
10 EXPLANATION OF SYMBOLS	
10.1 EXPLANATION OF SYMBOLS	12
11 DISPOSAL	
11.1 DISPOSAL	13
DECLARATION OF CONFORMITY	ENCLOSED

3. GUARANTEE

Draper tools have been carefully tested and inspected before shipment and are guaranteed to be free from defective materials and workmanship for a period of 12 months from the date of purchase except where tools are hired out when the guarantee period is 90 days from the date of purchase.

A proof of purchase must be provided with the tool.

Should the machine develop any fault, please return the complete tool to your nearest authorized warranty repair agent or contact Draper Tools Limited, Chandler's Ford, Eastleigh, Hampshire, SO53 1YF. England. Telephone Sales Desk: (023) 8049 4333 or Product Helpline (023) 8049 4344.

If upon inspection it is found that the fault occurring is due to defective materials or workmanship, repairs will be carried out free of charge. This guarantee does not apply to normal wear and tear, nor does it cover any damage caused by misuse, careless or unsafe handling, alterations, accident, or repairs attempted or made by any personnel other than the authorised Draper warranty repair agent.

Note: If the tool is found not to be within the terms of warranty, repairs and carriage charges will be quoted and made accordingly.

This guarantee applies in lieu of any other guarantee expressed or implied and variations of its terms are not authorised.

Your Draper guarantee is not effective unless you can produce upon request a dated receipt or invoice to verify your proof of purchase within the 12 month period.

Please note that this guarantee is an additional benefit and does not affect your statutory rights.

Draper Tools Limited

4. INTRODUCTION

4.1 SPECIFICATION

Stock no.	79359
Part no.	DE750A
Voltage	230V~50Hz
Motor	750W (1HP)
Air flow.....	14.15m ³ /min (500cfm)
Filtration	5 micron
Intake diameter.....	100mm
Bag dimensions	370(D)x640(H)mm
Vibration level.....	<2.5m/s ²
Weight	27kg

4.2 HANDLING & STORAGE

Care must be taken when handling and lifting. Dropping this machine will have an effect on the accuracy and may also result in personal injury. This machine is not a toy and must be respected.

The environment will have a negative result on its operation if you are not careful. If the air is damp, components will rust. If the machine is unprotected from dust and debris; components will become clogged: And if not cleaned and maintained correctly or regularly the machine will not perform at its best.

5. HEALTH & SAFETY INFORMATION

5.1 GENERAL SAFETY INSTRUCTIONS FOR POWER TOOL USE

WARNING:

Please read the following instructions carefully, failure to do so could lead to serious personal injury. When using electric tools, basic safety precautions, including the following, should always be followed to reduce the risk of fire, electric shock and personal injury. Read all these instructions before operating this product and save these instructions.

IMPORTANT:

Draper Tools Limited recommends that this machine should not be modified or used for any application other than that for which it was designed. If you are unsure of its relative applications do not hesitate to contact us in writing and we will advise you.

1. **KNOW YOUR POWER TOOL:** Read and understand the owner's manual and labels affixed to the tool. Learn its application and limitations as well as the specific potential hazards peculiar to this tool.
2. **KEEP WORK AREA CLEAN:** Cluttered areas and benches invite accidents. Floors must not be slippery due to oil or sawdust.
3. **AVOID DANGEROUS ENVIRONMENTS:** Do not use power tools in damp or wet locations, or expose them to rain. Keep work area well lit. Provide adequate space surrounding the work area. Do not use in environments with a potentially explosive atmosphere.
4. **KEEP CHILDREN AWAY:** All visitors should be kept a safe distance from work area.
5. **STORED TOOLS:** When not being used, all tools should be stored in a dry, locked cupboard and out of the reach of children.
6. **WEAR PROPER CLOTHING:** Do not wear loose clothing, neckties or jewellery (rings, wristwatches) to catch in moving parts. NONSLIP footwear is recommended. Wear protective hair covering to contain long hair. Roll long sleeves above the elbow.
7. **USE SAFETY GOGGLES (Head Protection):** Wear CE approved safety goggles at all times. Normal spectacles only have impact resistant lenses, they are NOT safety glasses. Also, use face or dust mask if application is dusty and ear protectors (plugs or muffs) during extended periods of operation.
8. **NOISE LEVELS:** Some types of machines may have high noise levels when working. In such cases ear protection must be worn.
9. **VIBRATION LEVELS:** Hand held power tools produce different vibration levels. You should always refer to the specifications and relevant Health and Safety guide.
10. **DUST EXTRACTION:** If your tool is fitted with a dust extraction fitting, always ensure that it is connected and being used with a dust extractor. Vacuum cleaners can be used if suitable for the material being extracted.
11. **PROTECT YOURSELF FROM ELECTRIC SHOCK:** When working with power tools, avoid contact with any earthed items (e.g. pipes, radiators, hobs and refrigerators, etc.). If you are using a power tool in extreme conditions (e.g. high humidity or generating metal dust), always use an RCD (residual current device) at the power socket.
12. **STAY ALERT:** Always watch what you are doing and use common sense. Do not operate a power tool when you are tired or under the influence of alcohol or drugs.
13. **WHEN WORKING OUT OF DOORS:** Only use extension leads designed for that purpose.
14. **ACCESS TO MAINS SOCKET:** If a stationary machine is fitted with a moulded plug and cable, the machine should not be positioned so that access to the mains socket is restricted.
15. **DISCONNECT POWER TO THE TOOL:** When not in use, before servicing and when changing accessories such as cutters, etc.
16. **AVOID ACCIDENTAL STARTING:** Make sure the switch is in the OFF position before plugging the machine into the power supply.
17. **NEVER LEAVE MACHINE RUNNING UNATTENDED:** Turn power off. Do not leave machine until it comes to a complete stop.
18. **DO NOT ABUSE THE CORD:** Never carry the tool by the power cable or pull it from the socket. Keep the power cable away from heat, oil and sharp edges. If the supply cord is damaged, it must be replaced by the manufacturer or its service agent or a similarly qualified person in order to avoid hazard.
19. **NEVER STAND ON TOOL:** Serious injury could occur if the tool is tipped or if the cutting tool is accidentally contacted. Do not store materials above or near the tool, so that it is necessary to stand on the tool to reach them.

5. HEALTH & SAFETY INFORMATION

20. **CHECK DAMAGED PARTS:** Before further use of the tool, a guard or other part that is damaged should be carefully checked to determine that it will operate properly and perform its intended function. Check for alignment of moving parts, free running of moving parts, breakage of parts, mounting and any other conditions that may affect its operation. A guard or other part that is damaged should be repaired properly or replaced by an authorized service centre unless otherwise indicated in this instruction manual. Have defective switches replaced by an authorized service facility. Do not use the tool if the switch does not turn it on and off.
21. **KEEP GUARDS IN PLACE:** And in working order.
22. **MAINTAIN TOOLS WITH CARE:** Keep tools sharp and clean for the best and safest performance. Follow instructions for lubricating and changing accessories. All extension cables must be checked at regular intervals and replaced if damaged. Always keep the hand grips on the tool clean, dry and free of oil and grease.
23. **USE RECOMMENDED ACCESSORIES:** Consult the owners manual for recommended accessories. Follow the instructions that accompany the accessories. The use of improper accessories may cause hazards.
24. **REMOVE ADJUSTING KEYS AND WRENCHES:** Form a habit of checking to see that keys and adjusting wrenches are removed from the tool before turning it on.
25. **SECURE WORK:** Use clamps or a vice to hold work. This frees both hands to operate the tool.
26. **DO NOT OVERREACH:** Keep proper footing and balance at all times.
27. **USE RIGHT TOOL:** Do not force the tool or attachment to do a job for which it was not designed.
28. **DO NOT FORCE TOOL:** It will do the job better and safer at the rate for which it was designed.
29. **DIRECTION OF FEED:** Feed work into a blade or cutter against the direction of rotation of the blade or cutter only.
30. **WHEN DRILLING OR SCREWING INTO WALLS:** Always make sure there is no danger of hitting any hidden power cables, water or gas pipes in the wall.
31. **HAVE YOUR TOOL REPAIRED BY A QUALIFIED PERSON:** This electric tool is in accordance with the relevant safety requirements. Repairs should only be carried out by qualified persons using original spare parts, otherwise this may result in considerable danger to the user.

IMPORTANT NOTE:

Residual Risk. Although the safety instructions and operating manuals for our tools contain extensive instructions on safe working with power tools, every power tool involves a certain residual risk which can not be completely excluded by safety mechanisms. Power tools must therefore always be operated with caution!

5.2 ADDITIONAL SAFETY INSTRUCTIONS FOR DUST EXTRACTORS

When using your dust extractor, follow these basic safety precautions:

WARNING:

To reduce the risk of fire, electric shock or injury, read and understand this instruction manual and all labels on the dust extractor before operating, use only as described in this manual.

1. **THE MOTOR DUCT:** Contains a high speed fan blade that can severely injure, grab loose clothing & propel dust at high velocities. **DO NOT OPERATE WITHOUT ALL PARTS FULLY ASSEMBLED.**
2. **DO NOT:** Attempt to clean, remove the dust bags or service the unit when the power is "ON". Turn the unit "OFF" and disconnect the cable from the power supply.
3. **STATIC SHOCKS:** Are common in dry areas or when the relative humidity of the air is low.
4. **SPARKS:** Inside the electrical parts can ignite flammable vapours.
5. **DO NOT:** Vacuum, or use the dust extractor near flammable or combustible liquids, gases, other fuels, cleaners, oil-based paints or explosive dusts, e.g. coal dust, grain dust or gun powder.
6. **DO NOT:** Vacuum anything that is burning or smoking, such as cigarettes, matches or hot ashes.
7. **TO AVOID HEALTH HAZARDS:** From vapours or dusts, do not vacuum toxic materials.
8. **DO NOT:** Use or store near hazardous material.
9. **DO NOT:** Use outdoors or on wet surfaces.
10. **PUT THE UNIT:** On a stable, level surface.
11. **POSITION:** The vacuum hose and electric cable away from pedestrian or vehicle traffic areas.
12. **DO NOT ALLOW:** The unit to be used as a toy. Do not use near children.
13. **DO NOT LEAVE:** The dust extractor plugged in. Unplug from the power supply when not in use and before servicing.

5. HEALTH & SAFETY INFORMATION

14. **TO AVOID INJURY:** From accidental starting, unplug the power cable before changing or cleaning the dust bag.
15. **DO NOT:** Use without the dust bag in place.
16. **DO NOT:** Unplug by pulling on the cable. To unplug, grasp the plug, not the cable.
17. **TURN OFF THE CONTROL:** Before unplugging.
18. **DO NOT:** Use with a damaged cable, plug or other parts. If your dust extractor is not working as it should, has missing parts, has been dropped, damaged, left outdoors, or dropped into water, return it to an authorised service agent for immediate repair, along with proof of purchase.
19. **DO NOT:** Pull or carry by the cable, or use the cable as a handle or pull the cable around sharp edges or corners. Do not run the dust extractor over the cable. Keep the cable away from heated surfaces.
20. **DO NOT:** Handle the plug of the dust extractor with wet hands.
21. **DO NOT:** Put any object into the ventilation openings. Do not vacuum with any ventilation opening blocked; keep free of dust, lint, hair or anything that may reduce air flow.
22. **KEEP:** Hair, loose clothing, finger and all parts of the body away from the openings and moving parts.
23. **EXTENSION CABLES:** In poor condition or that are too small can cause fire and shock hazards. When using an extension cable, be sure it is in good condition and suitable for the amperage rating of this machine.
24. **CONNECT:** To a correctly earthed power supply only.
25. **CAUTION:** If using this dust extractor to help reduce airborne wood dust in heavy usage within acceptable limits, you must regularly monitor airborne dust and empty/maintain your dust extractor to avoid exceeding dust limits. Each application is unique. Your maintenance schedule must therefore be tailored to your specific use of this dust extractor.
26. **SAFETY:** Is a combination of common sense, staying alert and knowing how your dust extractor works.
WARNING; To avoid mistakes that could result in serious injury, do not connect the power cable until the following steps have been completed;
27. **BEFORE USING THE DUST EXTRACTOR:**
 - a. Complete the assembly.
 - b. Learn the function and use of the "ON/OFF" switch.
 - c. Read and understand all safety instruction and operating procedures throughout the manual.
 - d. Read the labels which appear on the dust extractor.
28. **BEFORE EACH USE:**
 - a. Inspect your dust extractor if any parts are missing, bent or failed in any way or any electrical components do not work properly, turn off the dust extractor, turn off the switch and remove the plug from the power supply. Replace damaged, missing or failed parts before using the dust extractor again.
 - b. Plan your work and protect your eyes, hands, face, ears and body.
29. **WHEN CLEANING COLLECTION BAGS:** Always wear an approved dust mask.

5.3 CONNECTION TO THE POWER SUPPLY

Make sure the power supply information on the machine's rating plate are compatible with the power supply you intend to connect it to.

This dust extractor comes supplied with a UK standard 3 pin plug fitted. It is designed for connection to a domestic power supply rated at 230V AC.

Because it's constructed mostly of metal parts, it is a class 1 machine meaning it must have an earth connection in the power supply. This is to prevent electrocution in the event of a failure.

Apart from replacing the fuse in the plug, no other electrical work is recommended on this product.

6. TECHNICAL DESCRIPTION

6.1 IDENTIFICATION

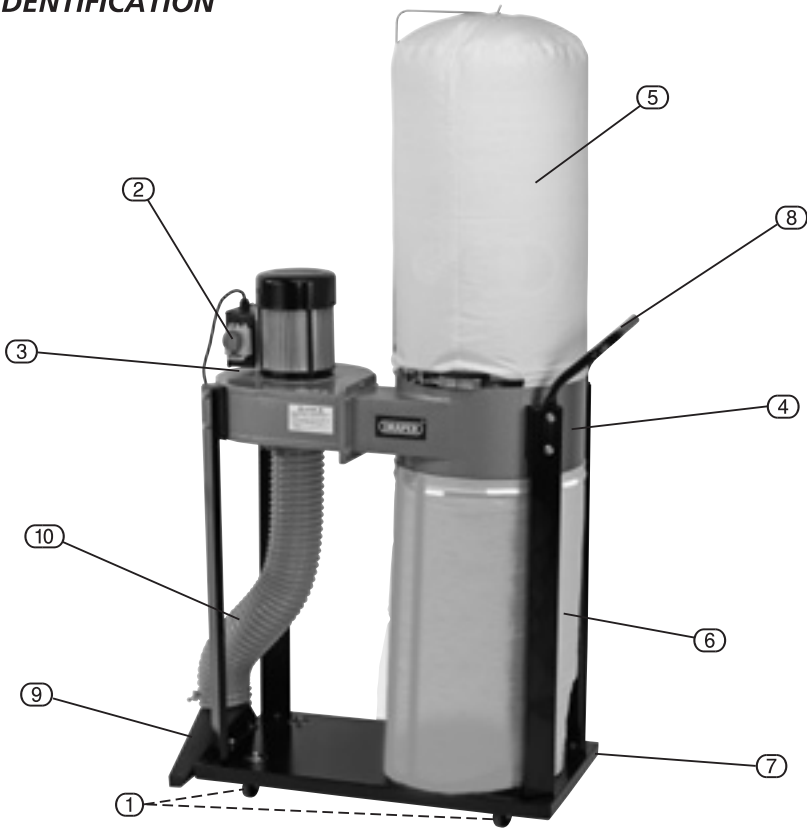

- ① Castors (x4).
- ② No-volt on/off switch.
- ③ Motor/ducting unit.
- ④ Collection bag ducting.
- ⑤ Filter bag.

- ⑥ Collection bag.
- ⑦ Base.
- ⑧ Handle.
- ⑨ Floor attachment.
- ⑩ Hose.

7. UNPACKING & CHECKING

7.1 PACKAGING

Carefully remove the product from the packaging and examine it for any sign of damage that may have happened during shipping. Lay the contents out and check them against the parts shown below. If any part is damaged or missing; please contact the Draper Helpline (the telephone number appears on the Title page) and do not attempt to use the dust extractor.

The packaging material should be retained at least during the guarantee period: in case the machine needs to be returned for repair.

Warning! Some of the packaging materials used may be harmful to children. Do not leave any of these materials in the reach of children.

If any of the packaging is to be thrown away, make sure they are disposed of correctly; according to local regulations.

7.2 WHAT'S IN THE BOX?

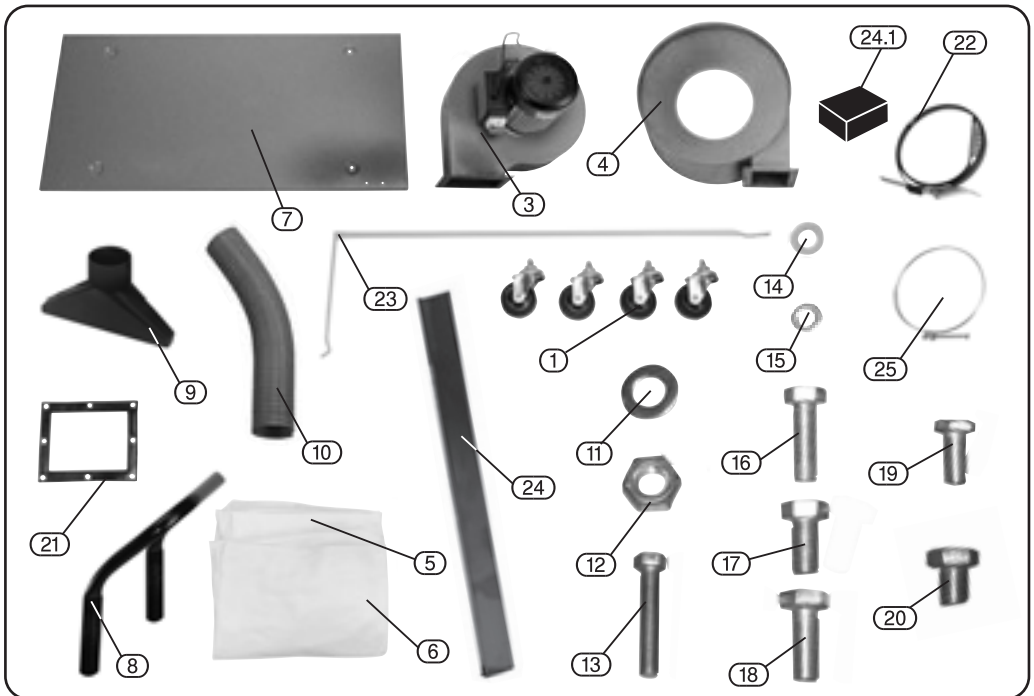

- | | | |
|---|----------------------------|------------------------|
| ① Castors with 8mm screws and 8mm M4 nuts (x4). | ⑨ Floor attachment. | ⑱ 6 × M6 × 15mm bolts. |
| ③ Motor/ducting unit. | ⑩ Hose. | ⑲ 2 × M4 × 10mm bolts. |
| ④ Collection bag ducting. | ⑪ 15 × 8mm Ø flat washers. | ⑳ 4 × M8 × 10mm bolts. |
| ⑤ Filter bag. | ⑫ 4 × M8 nuts. | ㉑ Gasket. |
| ⑥ Collection bag. | ⑬ 4 × M8 × 45mm bolts. | ㉒ Straps (x2). |
| ⑦ Base. | ⑭ 6 × 6mm Ø flat washers. | ⑳ Bag hook. |
| ⑧ Handle. | ⑮ 2 × 4mm Ø flat washers. | ㉓ Upright support. |
| | ⑯ 4 × M8 × 25mm bolts. | ㉔ Spacing block. |
| | ⑰ 2 × M8 × 15mm bolts. | ㉕ Hose clamps (x2). |

8. PREPARING THE DUST EXTRACTOR

NOTE: Remove the plug from the socket before carrying out adjustment, servicing or maintenance.

8.1 CASTORS - FIG. 1

Align the castors (1) on the underside of base (7) and secure with the four cross slot machine screws (8mm long), 8mm flat washers (11) and the 8mm (M4) nuts.

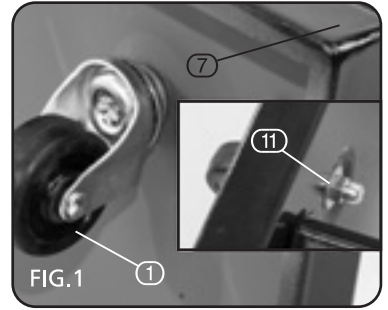

8.2 MOTOR/DUCTING UNIT & COLLECTION BAG DUCTING - FIG. 2

Align the motor/ducting unit (3) with the collection bag ducting (4). Insert gasket (21) between the two ducts before securing with the six (M6 x 15mm) bolts (18).

NOTE: Ensure there is one washer per bolt.

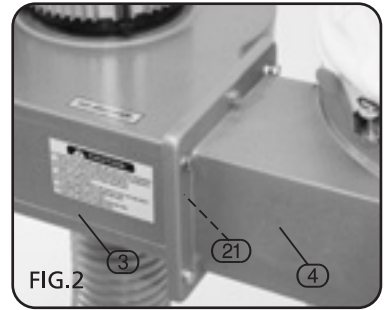

8.3 UPRIGHT SUPPORTS - FIGS. 3 - 4

Pass the two (M8 x 25mm) bolts (16) through the upright (24). The spacing block (24.1) and secure into the motor/ducting unit (3).

NOTE: Ensure there is one washer per bolt.

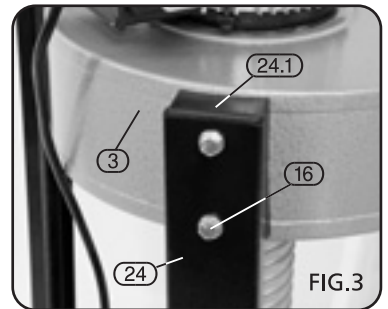

Pass the two (M8 x 45mm) bolts (13) through the handle (8), the upright (24), the spacing block (24.1) and the collection bag ducting (4) and secure in place with the (M8) nuts (12).

NOTE: Ensure there are two washers per bolt, one either side of the assembly.

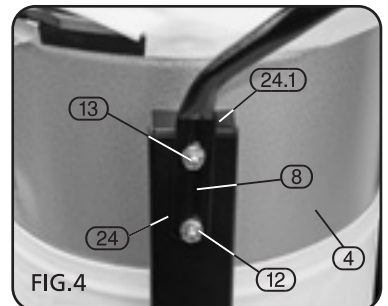

8. PREPARING THE DUST EXTRACTOR

NOTE: Remove the plug from the socket before carrying out adjustment, servicing or maintenance.

8.4 ASSEMBLY TO BASE - FIG. 5

Position the uprights (24) and the motor/collection bag ducting assembly (3)/(4) onto the base (7) in line with the remaining holes. Secure to the base with the 13mm (M8x10mm) bolts (20).

NOTE: Ensure there is one washer per bolt.

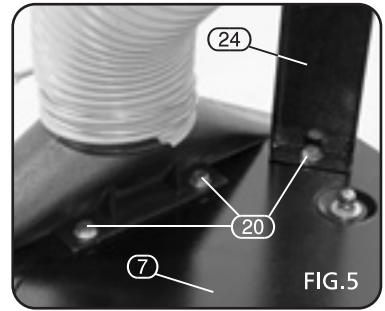

8.5 UPPER BAG HOOK - FIG. 6

Secure the upper bag hook (23) to the collection bag duct using the two M4 x 10mm bolts (19) and washers.

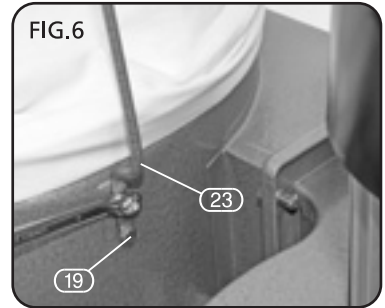

8.6 UPPER & LOWER BAGS - FIG. 7

Position the upper and lower bags (5) and (6) over the collection bag duct aperture (4). Overlap the metal strap (22) and with the clamp (22.1) in the open position, hook the spring over one of the teeth (22.2). Close the clamp (22.1) to secure the bag in place.

Ensure the bag is located fully and is straight to avoid an air gap which will allow dust to escape.

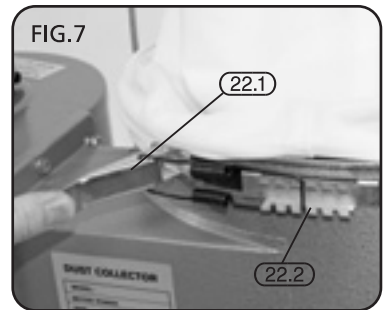

8.7 COLLECTION HOSE & FLOOR ATTACHMENT - FIG. 8

Using the hose clamps (25), attach the flexible hose (10) to the outlet on the underside of the motor/ducting unit (3).

Connect the other end to the floor attachment (9).

Secure the floor attachment to the base (7) with the remaining (M8 x 10mm) bolts (20) (as shown in fig. 5).

NOTE: Ensure there is one washer per bolt.

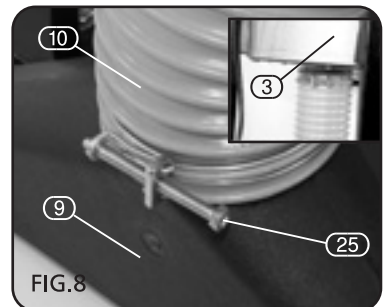

9. OPERATING INSTRUCTIONS

9.1 NO-VOLT ON/OFF SWITCH - FIG. 9

The dust extractor is equipped with a no-volt on/off switch (2).

In the event of a power supply disruption, the machine will require manually restarting once power has been returned.

To switch the machine on, press the green button marked 'I' (2.1).

To switch the machine off, press the red button marked 'O' (2.2). The yellow cover with integral red stop button (2.3) must be left covering the switches so, in the event of an accident or emergency, striking the stop button will activate the off switch.

IMPORTANT: Always wear an approved dust mask and goggles when operating this machine.

NOTE: Remove the plug from the socket before carrying out adjustment, servicing or maintenance.

9.2 EMPTYING THE COLLECTION BAG

This should be carried out at regular intervals or when the airborne dust content increases.

Depending on the workload, this may be necessary more often.

IMPORTANT: This machine is not suitable for fine dust or hazardous dust such as medium density fibreboard (MDF).

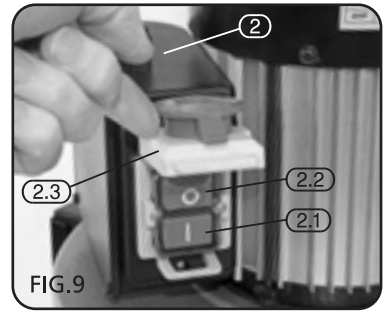

10. EXPLANATION OF SYMBOLS

10.1 EXPLANATION OF SYMBOLS



WEEE

Do not dispose of Waste
Electrical & Electronic Equipment
in with domestic rubbish

11. DISPOSAL

11.1 DISPOSAL

- At the end of the machine's working life, or when it can no longer be repaired, ensure that it is disposed of according to national regulations.
- Contact your local authority for details of collection schemes in your area.

In all circumstances:

- Do not dispose of power tools with domestic waste.
- Do not incinerate.
- Do not abandon in the environment.
- Do not dispose of WEEE* as unsorted municipal waste.



* Waste Electrical & Electronic Equipment.

- **DRAPER TOOLS LIMITED,**
Hursley Road, Chandler's Ford,
Eastleigh, Hampshire. SO53 1YF. U.K.

- **Helpline:** (023) 8049 4344
- **Sales Desk:** (023) 8049 4333
- **Internet:** www.drapertools.com
- **E-mail:** sales@drapertools.com
- **Sales Fax:** (023) 8049 4209
- **General Enquiries:** (023) 8026 6355

- **Service/Warranty Repair Agent**
For aftersales servicing or warranty repairs, please
contact the Draper Tools Helpline for details of an
agent in your local area.

YOUR DRAPER STOCKIST