



MICROMETER ADJUSTMENT **TORQUE WRENCHES**

72623 - PTW

72714 - PTW

83317 - PTW

IMPORTANT: PLEASE READ THESE INSTRUCTIONS CAREFULLY TO ENSURE THE SAFE AND EFFECTIVE USE OF THIS PRODUCT.



*83317 shown

INSTRUCTIONS

These instructions accompanying the product are the original instructions. This document is part of the product, keep it for the life of the product passing it on to any subsequent holder of the product. Read all these instructions before assembling, operating or maintaining this product.

This manual has been compiled by Draper Tools describing the purpose for which the product has been designed, and contains all the necessary information to ensure its correct and safe use. By following all the general safety instructions contained in this manual, it will ensure both product and operator safety, together with longer life of the product itself.

All photographs and drawings in this manual are supplied by Draper Tools to help illustrate the operation of the product.

Whilst every effort has been made to ensure the accuracy of information contained in this manual, the Draper Tools policy of continuous improvement determines the right to make modifications without prior warning.

1. TITLE PAGE

1.1 INTRODUCTION:

USER MANUAL FOR:

MICROMETER ADJUSTMENT TORQUE WRENCHES

Stock nos. 72623, 72714 and 83317.

Part no. PTW.

1.2 REVISIONS:

Date first published February 2017.

As our user manuals are continually updated, users should make sure that they use the very latest version.

Downloads are available from: <http://www.drapertools.com/manuals>

DRAPER TOOLS LIMITED

HURSLEY ROAD

CHANDLER'S FORD

EASTLEIGH

HAMPSHIRE

SO53 1YF

UK

WEBSITE:

drapertools.com

PRODUCT HELPLINE:

+44 (0) 23 8049 4344

GENERAL FAX:

+44 (0) 23 8026 0784

1.3 UNDERSTANDING THIS MANUALS SAFETY CONTENT:

WARNING! Information that draws attention to the risk of injury or death.

CAUTION! Information that draws attention to the risk of damage to the product or surroundings.

1.4 COPYRIGHT © NOTICE:

Copyright © Draper Tools Limited.

Permission is granted to reproduce this publication for personal & educational use only.

Commercial copying, redistribution, hiring or lending is prohibited.

No part of this publication may be stored in a retrieval system or transmitted in any other form or means without written permission from Draper Tools Limited.

In all cases this copyright notice must remain intact.

2. CONTENTS

2.1 CONTENTS

PAGE	CONTENT	PAGE
1	TITLE PAGE	
	1.1 INTRODUCTION	2
	1.2 REVISION HISTORY	2
	1.3 UNDERSTANDING THIS MANUAL	2
	1.4 COPYRIGHT NOTICE	2
2	CONTENTS	
	2.1 CONTENTS	3
3	GUARANTEE	
	3.1 GUARANTEE	4
4.	INTRODUCTION	
	4.1 SCOPE.....	5
	4.2 SPECIFICATION	5
	4.3 HANDLING & STORAGE	5
5.	HEALTH & SAFETY INFORMATION	6
6.	TECHNICAL DESCRIPTION	
	6.1 IDENTIFICATION	7
7.	UNPACKING & CHECKING	
	7.1 PACKAGING.....	8
8.	OPERATION AND USE	
	8.1 OPERATION INSTRUCTIONS.....	9 - 12
9.	CONVERSION CHART.....	13

3. GUARANTEE

3.1 GUARANTEE

Draper tools have been carefully tested and inspected before shipment and are guaranteed to be free from defective materials and workmanship.

Should the tool develop a fault, please return the complete tool to your nearest distributor or contact Draper Tools Limited, Chandler's Ford, Eastleigh, Hampshire, SO53 1YF. England.

Telephone Sales Desk: (023) 8049 4333 or Product Helpline (023) 8049 4344.

A proof of purchase must be provided with the tool.

If upon inspection it is found that a fault occurring is due to defective materials or workmanship, repairs will be carried out free of charge. The guarantee period covering parts/labour is 12 months from the date of purchase. This guarantee does not apply to normal wear and tear, nor does it cover any damage caused by misuse, careless or unsafe handling, alterations, accidents, or repairs attempted or made by any personnel other than the authorised Draper warranty repair agents.

Note: If the tool is found not to be within the Terms of Warranty, repair and carriage charges will be quoted and made accordingly.

This guarantee applies in lieu of any other guarantee expressed or implied and variations of its terms are not authorised.

Your Draper guarantee is not effective unless you can produce upon request a dated receipt or invoice to verify your proof of purchase within the guarantee period.

Please note that this guarantee is an additional benefit and does not affect your statutory rights.

Draper Tools Limited.

Note: The calibration period for the torque wrench starts from its first use and NOT from the date of calibration at the factory. The calibration is NOT affected during storage and the calibration certificate will not be "out of date".

4. INTRODUCTION

4.1 SCOPE

This torque wrench is used to apply a specific torque to a fastener such as a nut or bolt.

4.2 SPECIFICATION

Stock no.	72673	72714	83317
Part no.	PTW	PTW	PTW
Torque range	5-35Nm	25-135Nm	50-225Nm
.....	4-25lb/ft	20-100lb/ft	40-160lb/ft
Accuracy	+/- 4%	+/- 4%	+/- 4%
Square drive size	1/4"+3/8"	3/8"+1/2"	1/2"
Overall length approx	340mm	565mm	625mm

Manufactured and tested in accordance with to ISO 6789 Standards.

Whilst every effort has been made to ensure that the accuracy of information given in this manual is correct at time of going to print, the Draper Tools policy of continuous improvement determines the right to change specification without notice.

This torque wrench is accurate to $\pm 4\%$ of the set load and has been manufactured and tested in accordance to ISO 6789.

Torque tools are classified as test devices. If a calibration routine is required, the calibration interval shall be chosen on the basis of the factors of operation such as required accuracy, frequency of use, typical load during operation as well as ambient conditions during operation and storage conditions. The interval should be decided according to the user's procedures for the control of test devices and by the requirements of the user.

If the user does not use a control procedure, a period of use of 12 months, or approximately 5000 cycles can be taken as a default value of the recalibration interval. **For the first recalibration, the period of validity starts with user's first operation of the torque tool.**

In addition to these specifications, factory or legal regulations shall be observed.

The torque tool shall be recalibrated when it has been subjected to an overload greater than 125% of maximum rated load and after repair, or after any improper handling which might influence any errors in measurement.

4.3 HANDLING & STORAGE

Ensure you have a good stable position whilst using this product. Care should be exercised when using this product due to rotating parts etc.

Store the product together with this manual in its protective case in a cool dry place with the torque wrench set to its minimum setting.

This product should be cleaned, maintained and lubricated regularly to ensure it is operating at peak performance.

5. HEALTH & SAFETY INFORMATION

⚠ **WARNING!** Never use the torque wrench to undo bolts, nuts or fasteners, as this will damage the calibrated setting

Always adjust the torque wrench upwards through the scale to reach the required torque. Calibration will be affected if the torque required is set by coming down the scale.

IMPORTANT: Only pull the torque wrench in the direction of the arrow shown on the top face of the torque wrench.

Incorrect application of force in the wrong direction will permanently and irrevocably damage the torque wrench. Incorrect use of the torque wrench in this manner invalidates the warranty.

Always refer to manufacturer's literature, workshop manual, Autodata or Haynes manual for recommended TORQUE SETTINGS and if applicable the sequence for tightening and final torquing of fasteners.

If critical torque measurement is required, it is recommended the torque wrench is independently calibrated before first use and that the user puts in place a re-calibration schedule appropriate for the application.

6. TECHNICAL DESCRIPTION

6.1 IDENTIFICATION

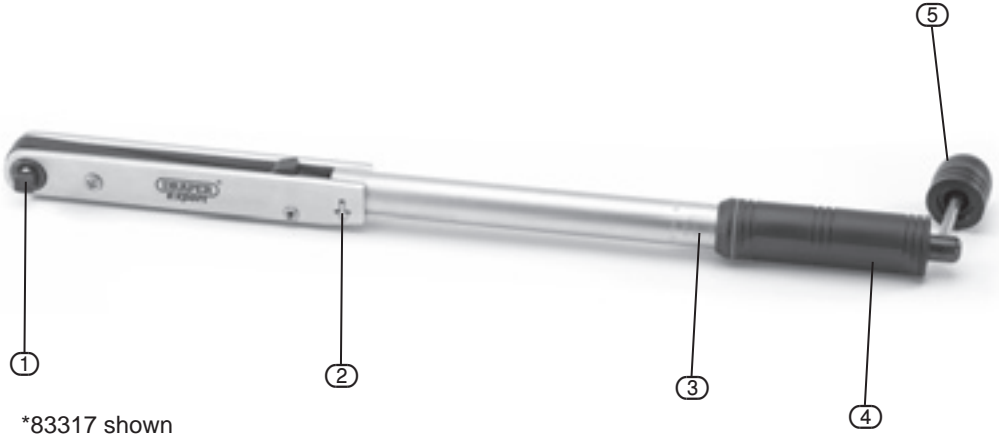

*83317 shown

- ① Push-through drive square.
- ② Direction arrow.
- ③ Torque scales.

- ④ Handle.
- ⑤ Torque setting handle.

Note: After use ALWAYS reset torque wrench to its lowest setting for storage. Storing at a level other than the lowest setting will affect torque wrench calibration.

7. UNPACKING & CHECKING

7.1 PACKAGING

Carefully remove the Torque wrench from the packaging and examine it for any sign of damage that may have happened during shipping. If it is damaged; please contact the Draper Helpline (the telephone number appears on the title page).

WARNING! Some of the packaging materials used may be harmful to children. Do not leave any of these materials in the reach of children.

If any of the packaging is to be thrown away, make sure they are disposed of correctly; according to local regulations.

8. OPERATING INSTRUCTIONS

8.1 OPERATION INSTRUCTIONS - FIG. 1

IMPORTANT:

Always use the correct size socket.

Apply a steady pull to the handle of the torque wrench. When the required torque is reached, this will be indicated by the following:

1. **Audible click:**

NOTE: The click will be quieter at lower torque settings.

2. **Touch:**

The handle will be felt to "break away" at the point of the set torque.

WARNING: At low torque levels the "break away" will be very soft. Check on a non-critical fastener before use so that you can familiarise yourself with this.

3. **Visually:**

The handle will be seen to "break away" at the point of the set torque.

WARNING: At low torque levels the "break away" will be very soft. Check on a non-critical fastener before use so that you can familiarise yourself with this.

WARNING:

Never continue to pull on the torque wrench once the set torque is reached, as this will result in an incorrect torque being applied and possible damage to parts.

If the torque wrench has not been used i.e. new or has been in storage for some time, operate it several times at a low torque setting, which allows the internal lubrication to recoat working parts.

When the torque wrench is not in use, adjust to the lowest torque setting for storage.

Do not turn adjustment below lowest torque setting.

Never use the torque wrench to undo nuts, bolts or fasteners. This will result in the mechanism being damaged.

The tool is rugged and designed for general use, but it is also a precision measuring instrument and should be treated as such.

Clean wrench by wiping. Do not immerse in any type of cleaner which will affect the internal lubrication.

Under no circumstances should any attempt be made to adjust or repair the torque wrench. A full repair and calibration service is available on request. A charge will be made accordingly.

It is recommended that a re-calibration schedule is put in place by the user to ensure the torque wrench is performing within its design criteria.

8. OPERATING INSTRUCTIONS

First select required torque scale, then pull-out torque setting handle (4), lock into the spindle at 90 degrees and turn until handle edge is at the required torque value.



NOTE: To obtain correct torque setting ONLY move the handle UPWARDS through the range. DO NOT set the torque required by moving down through the range as this will NOT give the correct torque setting.

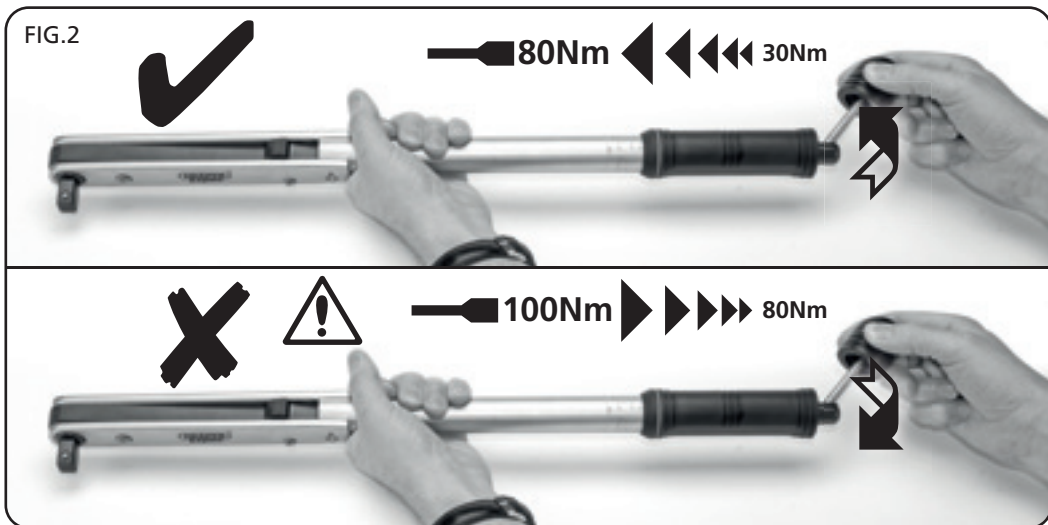

When correctly set, align and push the torque setting handle back into the handle body



8. OPERATING INSTRUCTIONS

Push the drive square ① through the head - checking the direction arrow ② of the torque wrench is correct for a left or right handed thread.

FIG.4



FIG.4.1



*72623 shown

NOTE: Items 72623 and 72714 have a double sided, dual drive adaptor. To change drive size, simply push out the drive square and re-insert to get the correct rotation for torque application.

IMPORTANT: Only pull in the direction of the arrow - incorrect application of force will irrevocably damage the torque wrench mechanism.

FIG.5

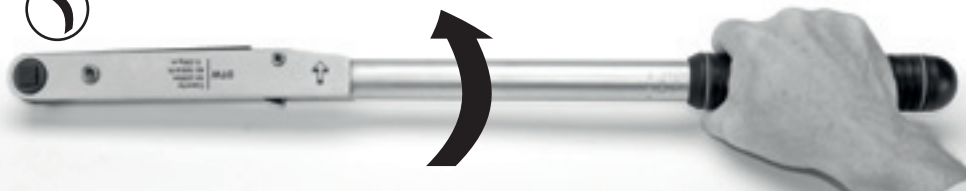
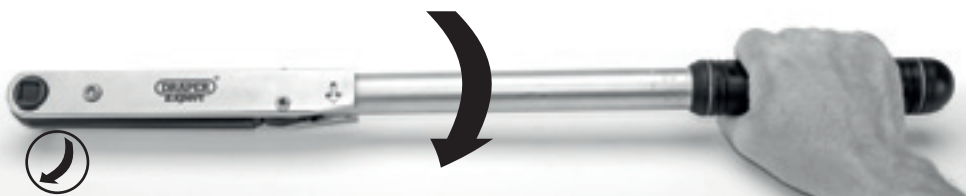

8. OPERATING INSTRUCTIONS

When the correct torque level has been reached stop pulling!

If you continue to apply torque after you can hear, feel and see the torque wrench “CLICK” you will damage your fixings. DO NOT apply torque again to “test” if the torque has been applied as this may damage the fixing.

After use ALWAYS rest the torque wrench to its lowest setting, clean with a soft dry cloth and return the torque wrench to its storage case for protection.

FIG.6



9. CONVERSION CHART

	mN/m millinewton- metre	cN/m centinewton- metre	N/m newton- metre	daN/m decanewton- metre	cm/kg centimetre- kg	m/kg metre- kg	in-oz inch- ounce	in-lb inch- pound	ft-lb foot- pound
1mN/m	1	0.1	0.001	0.0001	0.0102	0.000102	0.1416	0.00885	0.000738
1cN/m	10	1	0.01	0.001	0.102	0.00102	1.416	0.0885	0.00738
1N/m	1000	100	1	0.1	10.2	0.102	141.6	8.85	0.738
1daN/m	10000	1000	10	1	102	1.02	1416	88.5	7.38
1cm/kg	98	9.8	0.098	0.0098	1	0.01	13.9	0.868	0.0723
1m/kg	9810	981	9.81	0.98	100	1	1390	86.8	7.23
1in-oz	7.06	0.706	0.00706	0.0007	0.072	0.00072	1	16	192
1in-lb	112.9	11.29	0.1129	0.01129	1.152	0.0115	0.063	1	12
1ft-lb	1355	35	1.355	0.1135	13.8	0.138	0.0052	0.083	1

CONTACTS

- **DRAPER TOOLS LIMITED,**
Hursley Road, Chandler's Ford,
Eastleigh, Hampshire. SO53 1YF. U.K.
- **Helpline:** (023) 8049 4344
- **Sales Desk:** (023) 8049 4333
- **General Enquiries:** (023) 8026 6355
- **Service/Warranty Repair Agent**
For aftersales servicing or warranty repairs, please
contact the Draper Tools Helpline for details of an
agent in your local area.

YOUR DRAPER STOCKIST

PJDH0217

