



100W 230V Glue Gun Kit

Stock No.83660

Part No.PT655F

INSTRUCTIONS

1. INTRODUCTION

1.1 SPECIFICATION

Stock No.....	83660	Temperature.....	0-180°C
Part No.....	PT655F	Glue stick	11.2 x 100mm
Rated voltage	230V~50Hz	Weight (glue gun only).....	270g
Rated input.....	100W		

2. GUARANTEE

Draper tools have been carefully tested and inspected before shipment and are guaranteed to be free from defective materials and workmanship.

Should the tool develop a fault, please return the complete tool to your nearest distributor or contact Draper Tools Limited, Chandler's Ford, Eastleigh, Hampshire, SO53 1YF. England.

Telephone Sales Desk: (023) 8049 4333 or Product Help Line (023) 8049 4344.

A proof of purchase must be provided with the tool. If upon inspection it is found that the fault occurring is due to defective materials or workmanship, repairs will be carried out free of charge. This guarantee period covering parts/labour is 12 months from the date of purchase except where tools are hired out when the guarantee period is 90 days from the date of purchase. The guarantee is extended to 24 months for parts only. This guarantee does not apply to

normal wear and tear, nor does it cover any damage caused by misuse, careless or unsafe handling, alterations, accidents, or repairs attempted or made by any personnel other than the authorised Draper warranty repair agent.

Note: If the tool is found not to be within the terms of warranty, repairs and carriage charges will be quoted and made accordingly.

This guarantee applies in lieu of any other guarantee expressed or implied and variations of its terms are not authorised.

Your Draper guarantee is not effective unless you can produce upon request a dated receipt or invoice to verify your proof of purchase within the guarantee period.

Please note that this guarantee is an additional benefit and does not affect your statutory rights.

Draper Tools Limited.

3. HEALTH & SAFETY INFORMATION

- Keep out of the reach of children.
- Do not touch the nozzle area when hot.
- In case of contact with eyes, rinse immediately with plenty of water and seek medical advice.
- Keep away from sources of ignition.
- Do not leave the gun unattended during use.
- Do not breath vapour or spray.
- Avoid contact with hot glue. If accidental contact occurs, do not remove glue, immerse burn in water and seek medical advice.
- DO NOT USE THE GUN IN DAMP OR WET CONDITIONS OR EXPOSE IT TO RAIN.
 - Unplug the gun from the wall socket when not in use.
 - Never put any object in the gun other than the glue sticks recommended.
- Never take a glue stick out once it has been put into the gun: the resulting damage may be irreparable.
- RECOMMENDATIONS - REPAIRS
 - If the power supply cable is damaged it must be replaced by the manufacturer, the manufacturer's after sales service or a similarly qualified person in order to avoid any danger.
 - Should you wish to dispose of the tool always use recognized and dedicated recycling centre.
 - Children should be supervised to ensure that they do not play with the appliance.
- WARNING: This tool must be placed on its stand when not in use.
 - The appliance is designed for domestic use.

3. ASSEMBLY AND USE

4.1 SUPPORT STAND - FIG. 1

The built in support stand ① allows for safe positioning of the gun during gluing operations and for storage when not in use.

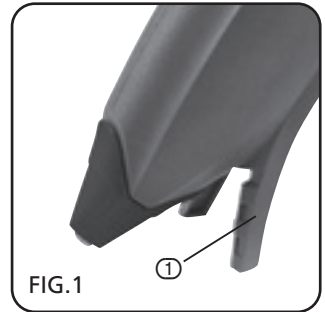

4.2 OPERATION - FIG. 2

Plug into wall socket and Insert the glue stick into the gun through the feeder tube ②. Then allow glue gun to heat up (5 mins approx). To further load the stick into the gun, squeeze the trigger several times. Apply glue to one of the two materials and press together within 15-20 seconds. The glue will set hard in approximately 1minute. When the glue stick has been used, a second stick will have to be used to push out the remains of the previous stick.

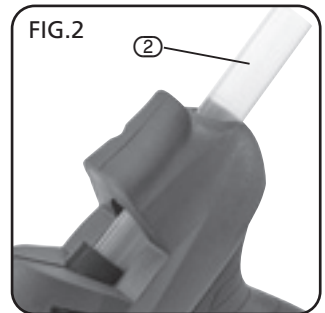

4.3 TRIGGER - FIG. 3

To start the flow of hot glue, squeeze trigger ③. The trigger may require several operations initially to begin flow. The glue sticks must be allowed to heat fully to flow properly. **WARNING:** If hot glue comes into contact with skin, a serious burn may occur.

Run burn under cold water for several minutes and seek medical attention if required.

Residual glue in the chamber of this glue gun may result in dripping. Ensure that work surface is suitably protected from dripping glue.

Avoid contact with the hot nozzle.



5. DISPOSAL

5.1 DISPOSAL

- At the end of the machine's working life, or when it can no longer be repaired, ensure that it is disposed of according to national regulations.

- Contact your local authority for details of collection schemes in your area.

In all circumstances:

- Do not dispose of power tools with domestic waste.
- Do not incinerate.
- Do not abandon in the environment.
- Do not dispose of WEEE* as unsorted municipal waste.
- * Waste Electrical & Electronic Equipment.

