



HAND

PALLET TRUCK

85655



These instructions accompanying the product are the original instructions. This document is part of the product, keep it for the life of the product passing it on to any subsequent holder of the product. Read all these instructions before assembling, operating or maintaining this product.

This manual has been compiled by Draper Tools describing the purpose for which the product has been designed, and contains all the necessary information to ensure its correct and safe use. By following all the general safety instructions contained in this manual, it will ensure both product and operator safety, together with longer life of the product itself.

All photographs and drawings in this manual are supplied by Draper Tools to help illustrate the operation of the product.

Whilst every effort has been made to ensure the accuracy of information contained in this manual, the Draper Tools policy of continuous improvement determines the right to make modifications without prior warning.

1. TITLE PAGE

1.1 INTRODUCTION:

USER MANUAL FOR: Hand Pallet Truck

Stock No's: 85655

Part No's: PT2500-B

1.2 REVISIONS:

Date first published November 2017.

As our user manuals are continually updated, users should make sure that they use the very latest version.

Downloads are available from: <http://drapertools.com/manuals>

Draper Tools Limited
Hursley Road
Chandler's Ford
Eastleigh
Hampshire
SO53 1YF
UK

Website: drapertools.com

Product Helpline: +44 (0) 23 8049 4344

General Fax: +44 (0) 23 8026 0784

1.3 UNDERSTANDING THIS MANUALS SAFETY CONTENT:

WARNING! – Information that draws attention to the risk of injury or death.

CAUTION! – Information that draws attention to the risk of damage to the product or surroundings.

1.4 COPYRIGHT © NOTICE:

Copyright © Draper Tools Limited.

Permission is granted to reproduce this publication for personal and educational use only. Commercial copying, redistribution, hiring or lending is prohibited.

No part of this publication may be stored in a retrieval system or transmitted in any other form or means without written permission from Draper Tools Limited.

In all cases this copyright notice must remain intact.

2. CONTENTS

1. TITLE PAGE	
1.1 INTRODUCTION.....	2
1.2 REVISION HISTORY	2
1.3 UNDERSTANDING THIS MANUAL	2
1.4 COPYRIGHT NOTICE	2
2. CONTENTS	
2.1 CONTENTS	3
3. GUARANTEE	
3.1 GUARANTEE	4
4. INTRODUCTION	
4.1 SCOPE	5
4.2 SPECIFICATION	5
4.3 HANDLING AND STORAGE	5
5. HEALTH AND SAFETY INFORMATION	
5.1 GENERAL SAFETY INSTRUCTIONS	6
5.2 HYDRAULIC FLUID DATA SHEET	6-7
6. TECHNICAL DESCRIPTION	
6.1 IDENTIFICATION	8
7. UNPACKING AND CHECKING	
7.1 PACKAGING	9
8. ASSEMBLING THE PALLET TRUCK	
8.1 ATTACH THE HANDLE TO THE PISTONS	10
9. PALLET TRUCK SETUP	
9.1 HYDRAULIC VALVE ADJUSTMENT.....	11
10. PALLET TRUCK INSTRUCTIONS	
10.1 LIFTING & LOWERING THE PALLET TRUCK.....	10
11. MAINTENANCE	
11.1 GENERAL MAINTENANCE	11
12. TROUBLESHOOTING	
12.1 TROUBLESHOOTING	12
13. DISPOSAL	
13.1 DISPOSAL	13
DECLARATION OF CONFORMITY	ENCLOSED

3. GUARANTEE

3.1 GUARANTEE

Draper tools have been carefully tested and inspected before shipment and are guaranteed to be free from defective materials and workmanship.

Should the tool develop a fault, please return the complete tool to your nearest distributor or contact:

Draper Tools Limited, Chandler's Ford, Eastleigh, Hampshire, SO53 1YF. England.

Telephone Sales Desk: (023) 8049 4333 or:

Product Helpline (023) 8049 4344.

A proof of purchase must be provided.

If upon inspection it is found that the fault occurring is due to defective materials or workmanship, repairs will be carried out free of charge. This guarantee period covering parts/labour is 12 months from the date of purchase except where tools are hired out when the guarantee period is 90 days from the date of purchase. This guarantee does not apply to normal wear and tear, nor does it cover any damage caused by misuse, careless or unsafe handling, alterations, accidents, or repairs attempted or made by any personnel other than the authorised Draper warranty repair agent.

Note: If the tool is found not to be within the terms of warranty, repairs and carriage charges will be quoted and made accordingly.

This guarantee applies in lieu of any other guarantee expressed or implied and variations of its terms are not authorised.

Your Draper guarantee is not effective unless you can produce upon request a dated receipt or invoice to verify your proof of purchase within the guarantee period.

Please note that this guarantee is an additional benefit and does not affect your statutory rights.

Draper Tools Limited.

4. INTRODUCTION

4.1 SCOPE

Ideal for use in warehouse environments.

4.2 SPECIFICATION

Stock No.	85655
Part No.	PT2500-B
Lifting capacity	2500kg
Maximum fork height	200mm
Minimum fork height	85mm
Fork length	1150mm
Fork width (overall)	540mm
Fork width (individual)	160mm
Load wheel diameter	80mm
Steering wheel diameter	200mm
Weight (nett)	72kg

4.3 HANDLING AND STORAGE

Care must still be taken when handling and lifting. Dropping this machine will have an effect on the machines function and may also result in personal injury. This machine is not a toy and must be respected.

The environment will have a negative result on its operation if you are not careful. If the air is damp, components will rust. If the machine is unprotected from dust and debris; components will become clogged: And if not cleaned and maintained correctly or regularly the machine will not perform at its best.

5. HEALTH AND SAFETY INFORMATION

Have this tool repaired by a qualified person. This tool is designed to conform to the relevant international and local standards and as such should be maintained and repaired by someone qualified; using only original parts supplied by the manufacturer: This will ensure the tool remains safe to use.

5.1 GENERAL SAFETY INSTRUCTIONS

The user shall work in accordance with the instruction handbook.

It is necessary that the operator can watch the lifting device and the load during all movements.

The user shall not work under the raised load until it is secured by suitable means.

Limitations - Do not use for:

- operations in severe conditions (e.g. extreme climates, freezer applications, strong magnetic fields etc.).
- operations subject to special rules (e.g. potentially explosive atmospheres, mines etc.).
- lifting of persons.

Caution:

Do not handle loads, the nature of which, could lead to dangerous situations (e.g. molten metal, acids, radiating materials, especially brittle loads).

The service life of the hydraulic fluid is approximately 2 years and the equipment 2-5 years.

During decommissioning of the equipment certain hazards should be understood and avoided:

- Dealing with hydraulic fluid - refer to the data sheet section for details.
- Only with the line pressure released and with the lifting arm fully lowered shall the equipment be disassembled. Goggles shall be worn should any high pressure hydraulic fluid be ejected.
- This equipment poses a trapping/crushing hazard, caution shall be observed.

In the case of hydraulic fluid leakage - refer to the data sheet section for details.

This equipment poses a significant trapping/crushing hazard and as such extreme caution should be taken when handling/operating.

Use only on a smooth, dry, level, firm good condition surface.

Do not exceed the rated capacity of the jack.

This is a lifting device only and is not designed or intended to be used for any other purpose.

Familiarise yourself with this manual before operating this jack to prevent damage to property, equipment or personal injury.

5.2 HYDRAULIC FLUID DATA SHEET

Always wear gloves and goggles when dealing with hydraulic fluid.

Hydraulic fluid composition is achieved when highly refining mineral oil by means of a solvent.

As a substance is not considered hazardous to health under normal conditions of use.

First Aid recommendations

- In case of ingestion:
Wash out mouth with clean water and seek medical advice. Do not induce vomiting.
- In case of contact with eyes:
Thoroughly flush eyes with clean water for 5 to 10 minutes and seek medical advice.
- In case of contact with skin:
Wash area with soap and water. Remove affected clothing and wash. If irritation persists, seek medical advice.
- Other:
Seek medical advice immediately.

5. HEALTH AND SAFETY INFORMATION

Hydraulic fluid is a combustible material and in the event of fire should be extinguished using a foam or dry powder fire extinguisher. Do not use water.

In the event of accidental release into the environment, measures to prevent spread must be adhered to. Do not contaminate rivers, waterways or drains. Spillage should be contained with sand, grit or other appropriate barriers. Warn bystanders as spillage may present a slip hazard. Hydraulic fluid is not biodegradable and may in fact bioaccumulate.

IMPORTANT:

Read instruction manual thoroughly before use.

WARNING:

For safe operation of this Manual Pallet Truck, please read the following instructions:

- Only trained personnel are to use this Manual Pallet Truck.
- Do not operate the Manual Pallet Truck until you have checked its condition. Give special attention to the wheels, handle, forks, lift and lower control and brakes (if so equipped). Do not operate damaged or faulty trucks. Do not attempt repairs unless you are trained and authorised to do so.
- Operate Manual Pallet Trucks only from the designated operating position. Never place any part of your body in the lifting mechanism or under the forks or load. Do not carry passengers.
- Do not handle unstable or loosely stacked loads. Use special care when handling long, high or wide loads to avoid losing the load, striking bystanders or tipping the truck.
- Do not overload the truck. Check capacity plate for carrying capacity information. Overloading may cause truck to perform incorrectly and could cause injury.
- The capacity of the truck assumes an evenly distributed load with the centre of the load being at the halfway point of the length of the forks.
- Make sure the length of the forks match the length of the pallet.
- Lower the forks to lowest height when the truck is not to be used.
- Manual Pallet Trucks are for general operation on level, flat, hard surfaces. If ramps are encountered, the truck may be stopped in emergencies by operating the lowering control which will lower the load to the ground, stopping the truck. If the truck has to be stopped in this manner care should be taken that no part of your body is near or under the load. It is important not to operate a Manual Pallet Truck on a grade with loads that are too heavy to be easily handled by the operator. Since these are manually operated trucks, they are not to be used by operators that are not physically capable of safely handling the trucks with a load.
- The truck shall be used, serviced and repaired according to the manufacturer and shall not be modified or attachments fitted.
- The truck shall not be used in places insufficiently illuminated.
- The truck shall not be turned at right angles to stop the truck.
- The truck shall not be used as a vehicle jack.
- The extremity of fork arms shall not be used as a lever to lift a load.
- The truck shall not be used in applications where a risk of exceeding the rated capacity exists.
- The truck shall not have direct contact with foodstuffs.
- The truck shall not be used in a potentially explosive atmosphere.

FAILURE TO FOLLOW THESE INSTRUCTIONS COULD RESULT IN LOSS OF LOAD AND/OR PERSONAL INJURY OR DAMAGE TO PROPERTY

6. TECHNICAL DESCRIPTION

6.1 IDENTIFICATION

- ① Handle.
- ② Release lever.
- ③ Steering wheels.
- ④ Pump assembly.
- ⑤ Front wheels.



7. UNPACKING AND CHECKING

7.1 PACKAGING

Carefully remove the machine from the packaging and examine it for any sign of damage that may have happened during shipping. Lay the contents out and check them against the parts shown below. If any part is damaged or missing; please contact the Draper Helpline (the telephone number appears on the Title page) and do not attempt to use the machine.

The packaging material should be retained at least during the guarantee period: in case the machine needs to be returned for repair.

Warning! Some of the packaging materials used may be harmful to children. Do not leave any of these materials in the reach of children.

If any of the packaging is to be thrown away, make sure they are disposed of correctly; according to local regulations.

8. ASSEMBLING THE PALLET TRUCK

8.1 ATTACH THE HANDLE TO THE PISTONS



Offer the handle up to the piston's pre-drilled holes.

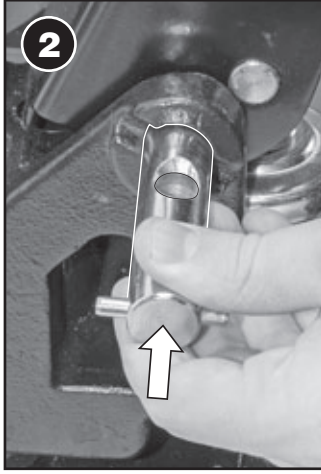

Whilst holding the handle in place slide the axle pin through the handle.

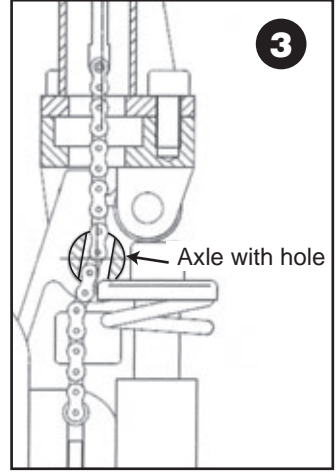

Adjust the control lever to the lower position. Then feed the chain and adjusting bolt/nut through the axle pin.

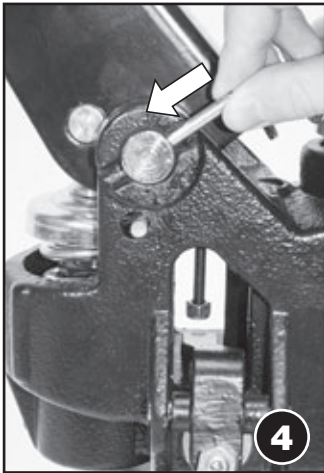

Secure the axle pin by locating the dowel pin (soft face hammer required).

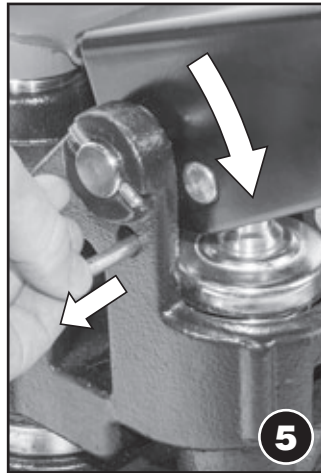

Push the handle down and remove the pump securing pin.

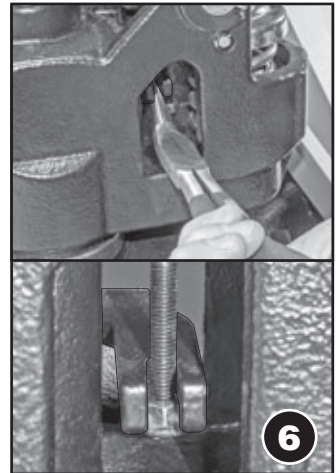

Adjust the control lever to the 'Lift' position. This will extend the length of the chain and adjusting bolt/nut. Lift the lever plate and slide the adjusting bolt through the slot.

Note: Using a curved tool (pry bar (Stock no.35396) /curved pliers (Stock no.69286)) allows enough clearance for the adjusting bolt to slide through the slot.

9. PALLET TRUCK SETUP

9.1 HYDRAULIC VALVE ADJUSTMENT:

On the handle of your pallet truck, you will find the control lever, which can be regulated in three positions:

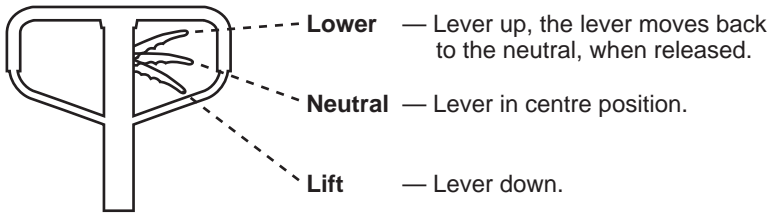

If necessary, you can adjust the lever according to following steps.

- a) If the forks elevate while pumping in the **Neutral** position, turn the adjusting nut on the adjusting bolt clockwise until pumping action does not raise the forks and the **Neutral** position works properly.
- b) If the forks descend while pumping in the **Neutral** position, turn the adjusting nut counter-clockwise until the forks do not lower.
- c) If the forks do not descent when the control lever is in the **Lower** position, turn the adjusting nut clockwise until raising the control lever lowers the forks. Then check the **Neutral** position works properly.
- d) If the forks do not elevate while pumping in the **Lift** position, turn the adjusting nut counter-clockwise until the forks elevate while pumping in the **Lift** position. Then check the **Lower** and **Neutral** position.

10. PALLET TRUCK INSTRUCTIONS

Do not use this pallet truck unless you are trained and authorised to do so.
Ensure the pallets used are suitable for use with the pallet truck.

10.1 LIFTING & LOWERING THE PALLET TRUCK:

- To lift the load, ensure that it is evenly distributed over both the forks and that the load to be lifted does not exceed 2500kg. Ensure the lever is in the down position so when the handle is lowered the load will be lifted.
- To move the load, ensure the lever is in the neutral position. Ensure the flooring meets the requirements of the load and ensure it is free of obstacles.
- To lower the load, gently lift the lever to the lower position. This will lower the pallet to the floor. Ensure nothing is under the pallet when lowering, e.g. feet.
- When the truck is not in use, ensure the forks are lowered and the lever is in the neutral position.

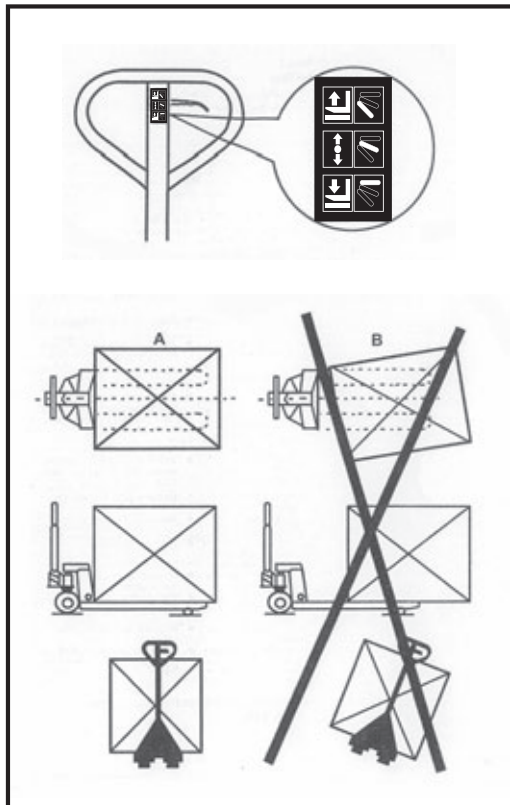

11. MAINTENANCE

11.1 MAINTENANCE

- OIL

Please check the oil level every 4 months. The oil capacity is about 0.3lt. Use the hydraulic type oil according to the temperature scale below.

Temperature	Oil
-20°C ~ +40°C	Hydraulic oil

- EXPELLING AIR FROM THE PUMP UNIT

Air may come into contact with the hydraulic oil because of transportation or pump in upset position. It can cause the forks to be unable to elevate while pumping in the RAISE position. Release the air in the following way: select the control handle on the LOWEST position, then move the handle up and down several times.

- DAILY CHECK AND MAINTENANCE

Check the overall condition of the pallet truck daily. Keep clean and lubricate all moving parts at regular intervals, special attention should be paid to the wheels, axles, threads etc. The forks should be unloaded and lowered in the lowest position when the job is complete.

- LUBRICATION

Use motor oil or grease to lubricate all moveable parts.

12. TROUBLESHOOTING

12.1 TROUBLESHOOTING GUIDE

Problems	Possible cause	Required action
- The forks cannot be lifted up to the maximum height.	- Hydraulic oil is low.	- Fill up the hydraulic oil.
- The forks cannot be lifted up	- No hydraulic oil. - The oil has impurities. - Air in the hydraulic oil.	- Fill up the hydraulic oil - Change the oil. - Purge the air from the hydraulic oil.
- The forks cannot be lowered.	- The piston rod or pump body is deformed resulting from partial loading, slanting to one side or overloading. - The fork was kept in the high position for a long time with the piston rod bared allowing it to rust and jam the rod.	- Replace the piston rod or pump body. - Keep the fork in the lowest position when not in use and lubricate the rod more regularly.
- Leaks.	- Seals worn or damaged. - Parts cracked or worn.	- Replace seals. - Replace worn or damaged parts.
- The forks lower without the release valve working.	- Impurities in the oil prevent the release valve from closing tight. - Parts of the hydraulic system cracked or worn. - Air in the hydraulic oil. - Seals worn or damaged.	- Replace with new oil. - Inspect and replace worn or damaged parts. - Purge the air from the system. - Replace seals.

13. DISPOSAL

13.1 DISPOSAL

- At the end of the machine's working life, or when it can no longer be repaired, ensure that it is disposed of according to national regulations.
- At the end of the useful life of the jack, drain off the oil and hand it over to an authorised agent and dispose of the jack in accordance with local regulations.

CONTACTS

Draper Tools Limited, Hursley Road,
Chandler's Ford, Eastleigh, Hampshire. SO53 1YF. U.K.

Helpline: (023) 8049 4344

Sales Desk: (023) 8049 4333

Internet: drapertools.com

E-mail: sales@drapertools.com

General Enquiries: (023) 8026 6355

Service/Warranty Repair Agent:

For aftersales servicing or warranty repairs, please contact the
Draper Tools Helpline for details of an agent in your local area.

YOUR DRAPER STOCKIST

RDCH0317

©Published by Draper Tools Limited.

No part of this publication may be reproduced, stored in a retrieval system or transmitted in any form or by any means, electronic, mechanical photocopying, recording or otherwise without prior permission in writing from Draper Tools Ltd.