

**DRAPER**<sup>®</sup>

# RECHARGEABLE **WORKLIGHT**

31296 & 31583 & 87381



CE

These instructions accompanying the product are the original instructions. This document is part of the product, keep it for the life of the product passing it on to any subsequent holder of the product. Read all these instructions before assembling, operating or maintaining this product.

This manual has been compiled by Draper Tools describing the purpose for which the product has been designed, and contains all the necessary information to ensure its correct and safe use. By following all the general safety instructions contained in this manual, it will ensure both product and operator safety, together with longer life of the product itself.

All photographs and drawings in this manual are supplied by Draper Tools to help illustrate the operation of the product.

Whilst every effort has been made to ensure the accuracy of information contained in this manual, the Draper Tools policy of continuous improvement determines the right to make modifications without prior warning.

# 1. TITLE PAGE

---

## 1.1 INTRODUCTION:

**USER MANUAL FOR: Rechargeable Worklight**  
**Stock No: 31296 & 31583 & 87381**  
**Part No: RFL/1000/B & RFL/1000/G & RFL/1000/Y**

## 1.2 REVISIONS:

**Date first published April 2019.**

---

---

---

---

As our user manuals are continually updated, users should make sure that they use the very latest version.

**Downloads are available from:** <http://drapertools.com/manuals>

Draper Tools Limited  
Hursley Road  
Chandler's Ford  
Eastleigh  
Hampshire  
SO53 1YF  
UK

**Website:** [drapertools.com](http://drapertools.com)

**Product Helpline:** +44 (0) 23 8049 4344

**General Fax:** +44 (0) 23 8026 0784

## 1.3 UNDERSTANDING THIS MANUALS SAFETY CONTENT:

**WARNING!** – Information that draws attention to the risk of injury or death.

**CAUTION!** – Information that draws attention to the risk of damage to the product or surroundings.

## 1.4 COPYRIGHT © NOTICE:

Copyright © Draper Tools Limited.

Permission is granted to reproduce this publication for personal and educational use only. Commercial copying, redistribution, hiring or lending is prohibited.

No part of this publication may be stored in a retrieval system or transmitted in any other form or means without written permission from Draper Tools Limited.

In all cases this copyright notice must remain intact.

---

## 2. CONTENTS

---

<b>1. TITLE PAGE</b>	
1.1 INTRODUCTION .....	2
1.2 REVISION HISTORY .....	2
1.3 UNDERSTANDING THIS MANUAL .....	2
1.4 COPYRIGHT NOTICE.....	2
<b>2. CONTENTS</b>	
2.1 CONTENTS .....	3
<b>3. WARRANTY</b>	
3.1 WARRANTY.....	4
<b>4. INTRODUCTION</b>	
4.1 SCOPE.....	4
4.2 SPECIFICATION .....	4
4.3 HANDLING AND STORAGE .....	4
<b>5. HEALTH AND SAFETY INFORMATION</b>	
5.1 GENERAL SAFETY INSTRUCTIONS .....	4-5
- 1) Work area safety .....	5
- 2) Electrical Safety .....	5
- 3) Personal Safety .....	5
- 4) Power Tool Use and Care.....	5
- 5) Battery tool Use and Care .....	5
- 6) Service .....	5
5.2 ADDITIONAL SAFETY INFORMATION .....	5
<b>6. TECHNICAL DESCRIPTION</b>	
6.1 IDENTIFICATION .....	6
<b>7. UNPACKING AND CHECKING</b>	
7.1 PACKAGING .....	7
7.2 WHAT'S IN THE BOX? .....	7
<b>8. ASSEMBLING THE WORKLIGHT</b>	
8.1 POWER SUPPLY.....	7
8.2 CHARGING .....	7
<b>9. WORKLIGHT INSTRUCTION</b>	
9.1 OPERATION .....	8
9.2 WORKLIGHT OPERATION.....	8
9.3 USB POWER TAKE OFF .....	8
<b>10. MAINTENANCE</b>	
10.1 MAINTENANCE .....	8
<b>11. EXPLANATION OF SYMBOLS</b>	
11.1 EXPLANATION OF SYMBOLS .....	9
<b>12. DISPOSAL</b>	
12.1 DISPOSAL.....	9
12.2 HEALTH AND SAFETY FOR BATTERIES.....	9
<b>DECLARATION OF CONFORMITY .....</b>	<b>ENCLOSED</b>

## 3. WARRANTY

### 3.1 WARRANTY

Draper tools have been carefully tested and inspected before shipment and are guaranteed to be free from defective materials and workmanship.

Should the tool develop a fault, please return the complete tool to your nearest distributor or contact

**Draper Tools Limited, Chandler's Ford, Eastleigh, Hampshire, SO53 1YF. England.**

**Telephone Sales Desk: (023) 8049 4333 or Product Help Line (023) 8049 4344.**

A proof of purchase **must** be provided with the tool.

If upon inspection it is found that the fault occurring is due to defective materials or workmanship, repairs will be carried out free of charge. This warranty period covering labour is 12 months from the date of purchase except where tools are hired out when the warranty period is 90 days from the date of purchase. The warranty is extended to 24 months for parts only. This warranty does not apply to any consumable parts, any type of battery or normal wear and tear, nor does it cover any damage caused by misuse, careless or unsafe handling, alterations, accidents, or repairs attempted or made by any personnel other than the authorised Draper warranty repair agent.

**Note:** If the tool is found not to be within the terms of warranty, repairs and carriage charges will be quoted and made accordingly.

This warranty applies in lieu of any other warranty expressed or implied and variations of its terms are not authorised.

Your Draper warranty is not effective unless you can produce upon request a dated receipt or invoice to verify your proof of purchase within the warranty period.

Please note that this warranty is an additional benefit and does not affect your statutory rights.

**Draper Tools Limited.**

## 4. INTRODUCTION

### 4.1 SCOPE

Rechargeable COB worklight with handle and pivot stand. Supplied with Micro USB to USB cable for charging the worklight and power take off for charging mobile devices.

### 4.2 SPECIFICATION

Stock no.....	31296 & 31583 & 87381
Part no.....	RFL/1000/B & RFL/1000/G & RFL/1000/Y
LED .....	10W flood + 5W spot COB
Luminosity .....	1000 lumens
Battery:	
Type .....	Li-ion
Rated Voltage .....	3.7V
Rating .....	2.2Ah
Charging time .....	6 hrs
Operating time .....	4 hrs
IP rating .....	IP44
Dimensions.....	196x132x60mm
Weight (worklight only) .....	750g

### 4.3 HANDLING AND STORAGE

Do not drop the worklight as this can damage and shorten the life span of the unit.

Store in a dry location as damp conditions can damage the worklight.

Charging on a regular basis is advised to prolong the life of the battery cells.

## 5. HEALTH AND SAFETY INFORMATION

### 5.1 GENERAL SAFETY INSTRUCTIONS

General Power Tools Safety Warnings

**WARNING:** Read all instructions. Failure to follow all instructions listed below may result in electric shock, fire and/or serious injury.

Save all warnings and instructions for future reference.

The term "power tool" in the warnings refers to your mains operated (corded) power tool or battery operated (cordless) power tool.

#### 1) Work area safety

- Keep work area clean and well lit.** Cluttered or dark areas invite accidents.
- Do not operate power tools in explosive atmospheres, such as in the presence of flammable liquids, gases or dust. Power tools create sparks which may ignite the dust or fumes.**
- Keep children and bystanders away while operating a power tool.** Distractions can cause you to lose control.

#### 2) Electrical Safety

- Power tool plugs must match the outlet.** Never modify the plug in any way. Do not use any adapter plugs with earthed (grounded) power tools. Unmodified plugs and matching outlets will reduce risk of electrical shock.
- Avoid body contact with earthed or grounded surfaces such as pipes, radiators, ranges and refrigerators.** There is an increased risk of electric shock if your body is earthed or grounded.
- Do not expose power tools to rain or wet conditions.** Water entering a power tool will increase the risk of electric shock.
- Do not abuse the cord. Never use the cord for carrying, pulling or unplugging the power tool.** Keep cord away from heat, oil, sharp edges or moving parts. Damaged or entangled cords increase the risk of electric shock.
- When operating a power tool outdoors, use an extension cord suitable for outdoor use.** Use of a cord suitable for outdoor use reduces the risk of electric shock.
- If operating a power tool in a damp location is unavoidable, use a residual current device (RCD) protected supply.** Use of an RCD reduces the risk of electric shock.

#### 3) Personal Safety

- Stay alert, watch what you are doing and use common sense when operating a power tool. Do not use a power tool while you are tired or under the influence of drugs, alcohol or medication.** A moment of inattention while operating power tools may result in serious personal injury.
- Use personal protective equipment. Always wear eye protection.** Protective equipment such as dust mask, non-skid safety shoes, hard hat, or hearing protection used for appropriate conditions will reduce personal injuries.

## 5. HEALTH AND SAFETY INFORMATION

---

- c) **Prevent unintentional starting. Ensure the switch is in the off position before connecting to power source and/or battery pack, picking up or carrying the tool.** Carrying power tools with your finger on the switch or energising power tools that have the switch on invites accidents.
- d) **Remove any adjusting key or wrench before turning the power tool on.** A wrench or a key left attached to a rotating part of the power tool may result in personal injury.
- e) **Do not overreach. Keep proper footing and balance at all times.** This enables better control of the power tool in unexpected situations.
- f) **Dress properly. Do not wear loose clothing or jewellery. Keep your hair, clothing and gloves away from moving parts.** Loose clothes, jewellery or long hair can be caught in moving parts.
- g) **If devices are provided for the connection of dust extraction and collection facilities, ensure these are connected and properly used.** Use of dust collection can reduce dust related hazards.

### 4) Power Tool Use and Care

- a) **Do not force the power tool. Use the correct power tool for your application.** The correct power tool will do the job better and safer at the rate for which it was designed.
- b) **Do not use the power tool if the switch does not turn it on and off.** Any power tool that cannot be controlled with the switch is dangerous and must be repaired.
- c) **Disconnect the plug from the power source and/or the battery pack from the power tool before making any adjustments, changing accessories, or storing power tools.** Such preventive safety measures reduce the risk of starting the power tool accidentally.
- d) **Store idle power tools out of the reach of children and do not allow persons unfamiliar with the power tool or these instructions to operate the power tool.** Power tools are dangerous in the hands of untrained users.
- e) **Maintain power tools. Check for misalignment or binding of moving parts, breakage of parts and any other condition that may affect the power tools operation. If damaged, have the power tool repaired before use.** Many accidents are caused by poorly maintained power tools.
- f) **Keep cutting tools sharp and clean.** Properly maintained cutting tools with sharp cutting edges are less likely to bind and are easier to control.
- g) **Use the power tool, accessories and tool bits etc., in accordance with these instructions, taking into account the working conditions and the work to be performed.** Use of the power tool for operations different from intended could result in a hazardous situation.

### 5) Battery Tool Use and Care

- a) **Recharge only with the charger specified by the manufacturer.** A charger that is suitable for one type of battery pack may create a risk of fire when used with another battery pack.
- b) **Use power tools only with specifically designated battery packs.** Use of any other battery packs may create a risk of injury and fire.
- c) **When battery pack is not in use, keep it away from other metal objects, like paper clips, coins, keys, nails, screws or other small metal objects, that can make a connection from one terminal to another.** Shorting the battery terminals together may cause burns or a fire.
- d) **Under abusive conditions, liquid may be ejected from the battery; avoid contact.** If contact accidentally occurs, flush with water. If liquid contacts eyes, additionally seek medical help. Liquid ejected from the battery may cause irritation or burns.

### 6) Service

- a) **Have your power tool serviced by a qualified repair person using only identical replacement parts.** This will ensure that the safety of the power tool is maintained.

## 5.2 ADDITIONAL SAFETY INFORMATION

- Close supervision is necessary when the unit is used by or near children. Do not use as a toy.
- To protect against risk of electrical shock or fire, do not put unit or charger in water or other liquid.
- Do not put this unit in a fire or near any flammable object as this may cause explosion.
- Do not drop, throw or use excessive force on the unit as it may cause permanent damage to the product.
- Do not operate the unit if it has been wet or moist to prevent against electric shock, explosion and/or injury to yourself and damage to the unit.
- Recharge indoors only, using only the charger supplied.
- Use the charger only in a standard electrical outlet.
- Do not attempt to disassemble the unit as this may cause damage.
- Do not shine directly into eyes.
- Unplug the charger before any routine cleaning or maintenance. Never let any liquid get inside the unit, use only mild soap and damp cloth to clean outer surfaces of the unit.
- The built-in Li-ion battery must be recycled or disposed of properly, do not expose the battery to fire or intense heat as it may explode.
- Do not overcharge the unit, recharge not more than 12 continuous hours.
- To assure product safety and reliability, repairs, maintenance and adjustment should be performed by authorised service centres or other qualified service organisations, always using identical replacement parts.

## 6. TECHNICAL DESCRIPTION

### 6.1 IDENTIFICATION

- ① On/Off button.
- ② Support stand.
- ③ Handle.
- ④ Flood light.
- ⑤ Spot / Red warning lights.
- ⑥ Battery charge indicator.
- ⑦ USB output port.
- ⑧ Micro USB charging socket.

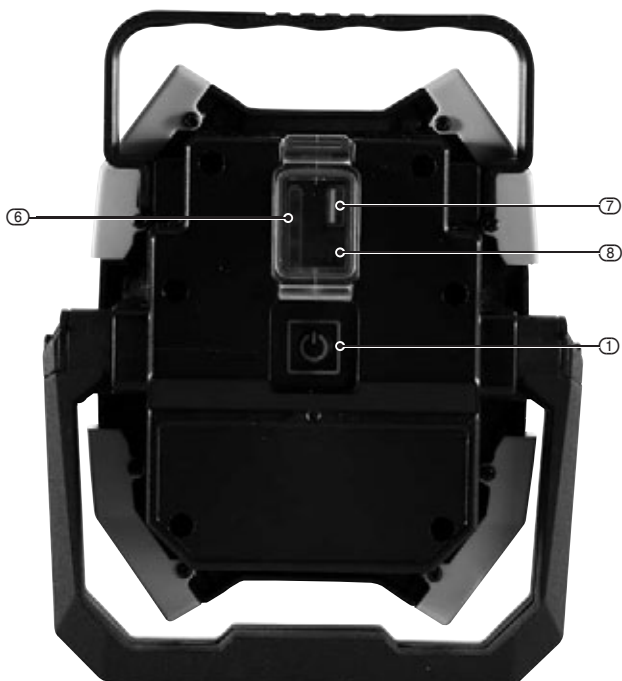

## 7. UNPACKING AND CHECKING

### 7.1 PACKAGING

Carefully remove the worklight from the packaging and examine it for any sign of damage that may have happened during shipping. If any part is damaged or missing; please contact the Draper Helpline (the telephone number appears on the Title page) and do not attempt to use the lamp.

**Warning!** Some of the packaging materials used may be harmful to children. Do not leave any of these materials in the reach of children.

If any of the packaging is to be thrown away, make sure they are disposed of correctly; according to local regulations.

### 7.2 WHAT'S IN THE BOX?

As well as the worklight; there are separate parts not fitted or attached to it.



⑨ Micro USB cable.

## 8. ASSEMBLING THE WORKLIGHT

### 8.1 POWER SUPPLY

Before you connect the equipment to the power supply make sure that the data on the rating plate is identical to the supply voltage.

**Warning!** Always pull out the power plug before making adjustments to the equipment.

**Warning:** Do not connect the machine to the power supply before the product is completely assembled.

### 8.1 CHARGING

**NOTE:** The micro USB connector is tapered and will only go in one way, do not force the micro USB connector into the lamp; as it may damage the connector or short circuit the lamp, this may invalidate your guarantee.

Connect the charging micro USB cable into the charging socket, which is located under the cover at the end of the spotlight. Connect the other USB A plug to a USB output adaptor (not supplied). The red LED charging indicator will illuminate to indicate charging, and the top blue LED will be on when the battery is fully charged.

Disconnect the charger from the spotlight when it is fully charged.

Lithium-ion cells prefer small charges often.

Lithium-ion technology is lightweight and compact due to increased capacity in comparison to other battery chemistries.

Lithium-ion cells have no 'memory effect' and a long cycle life with outstanding discharge performance.

Lithium-ion cells suffer from a loss in capacity or thermal runaway if over charged and will degrade if allowed to enter deep discharge, however all of these situations are negated due to the complex circuitry incorporated within this product.

Charging must be carried out in an environment with an ambient air temperature between 5°C to 45°C with the transformer supplied.

To prevent overheating, do not cover the transformer.

**Attention:** If the cable is damaged or the non-self-resetting protective device is activated due to short circuit/overload the transformer shall be scrapped. A replacement of identical specification, design and application shall be obtained.

**Note:** Charging the unit with the 12V DC charger via a vehicle socket will drain the vehicle's battery unless the engine is running.

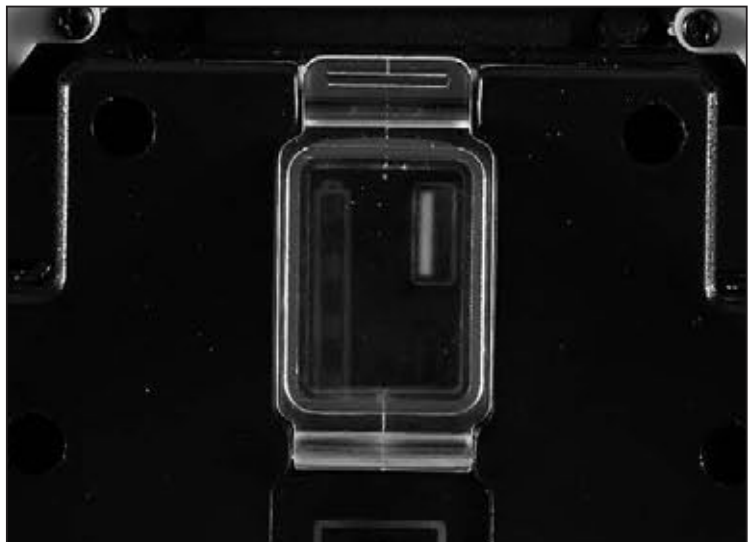

## 9. WORKLIGHT INSTRUCTION



### 9.1 OPERATION

**CAUTION:** Never shine the LED light directly into your or any one else's eyes.

To run through the sequence of modes (Flood Light, Spot Light, Red Warning Light and Off). Press the on/off ① button.

### 9.2 WORKLIGHT OPERATION

The worklight is operated via the ON/OFF switch ①.

- ① Press once for flood light.
- ② Press twice for spot light.
- ③ Press third time for red warning light.
- ④ Press fourth time to switch off the worklight.

**Warning!** Do not shine directly into any person's or animal's eyes.

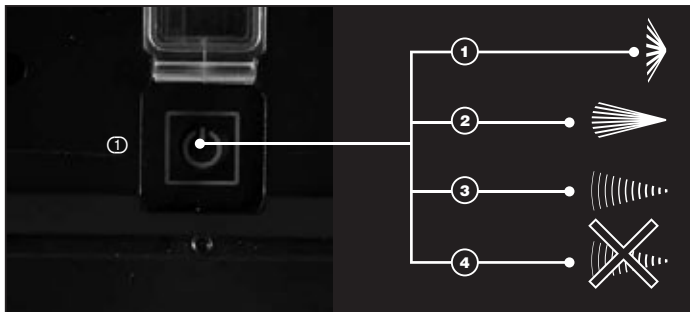

### 9.3 USB POWER TAKE OFF

Connect the USB end of the power cord into the USB output port beneath the cover, and connect the Micro USB end to your mobile device for charging (max. 5V 1Amp).

## 10. MAINTENANCE

### 10.1 MAINTENANCE

Use only mild soap and a damp cloth to clean this spotlight. Do not submerge into liquid.

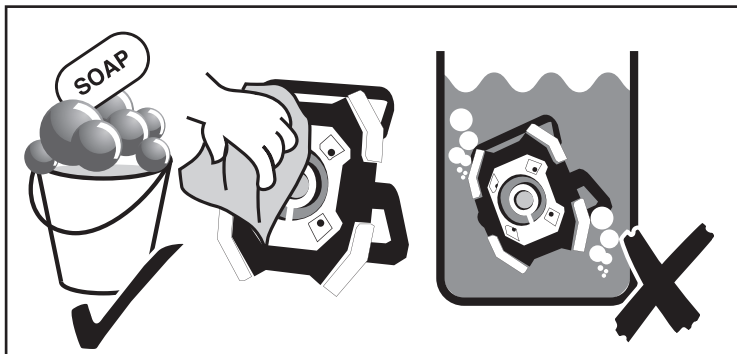



# 11. EXPLANATION OF SYMBOLS

## 11.1 EXPLANATION OF SYMBOLS



WEEE  
Do not dispose of Waste Electrical & Electronic Equipment in with domestic rubbish.



Lithium-ion product.  
Refer to your local authority for advice on disposal and recycling.



For indoor use only.  
Do not expose to rain.



Do not incinerate or throw onto fire.



Warning! Read the instruction manual.



Warning! Do not aim beam at bystanders or look directly into light source.

## 12. DISPOSAL

### 12.1 DISPOSAL

At the end of the machine's working life, or when it can no longer be repaired, ensure that it is disposed of according to national regulations.

Contact your local authority for details of collection schemes in your area.

In all circumstances:

- Do not dispose of power tools with domestic waste.
- Do not incinerate.
- Do not abandon in the environment.
- Do not dispose of WEEE\* as unsorted municipal waste.



Li-ion

### 12.2 HEALTH AND SAFETY FOR BATTERIES

**Warning!** Do not put in fire or mutilate – cells may burst or release toxic materials.

- Do not short circuit cells, may cause burns.
- The battery must be removed from the appliance before it is scrapped.
- The battery is to be disposed of safely.
- Do not mutilate batteries, corrosive electrolyte will be released.
- Do not incinerate – danger of explosion and release of toxic fumes.
- Do not dispose of batteries or cells in a charged condition.

Expired lithium-ion batteries must be recycled/disposed of in accordance with the appropriate regulation or legislation. They should be returned to your local warranty agent/stockist.

\* Waste Electrical & Electronic Equipment.

## CONTACTS

Draper Tools Limited, Hursley Road,  
Chandler's Ford, Eastleigh, Hampshire. SO53 1YF. U.K.

Helpline: (023) 8049 4344

Sales Desk: (023) 8049 4333

Internet: [drapertools.com](http://drapertools.com)

E-mail: [sales@drapertools.com](mailto:sales@drapertools.com)

General Enquiries: (023) 8026 6355

Service/Warranty Repair Agent:

For aftersales servicing or warranty repairs, please contact the  
Draper Tools Helpline for details of an agent in your local area.

YOUR DRAPER STOCKIST

RWTL0419

©Published by Draper Tools Limited.

No part of this publication may be reproduced, stored in a retrieval system or transmitted in any form or by any means, electronic, mechanical photocopying, recording or otherwise without prior permission in writing from Draper Tools Ltd.