

DRAPER[®]

[®]

ASSEMBLY DETAILS FOR
**550mm Precision
Mitre Saw**

Stock No.88192 Part No.PMS/550

IMPORTANT: PLEASE READ THESE INSTRUCTIONS CAREFULLY TO ENSURE THE SAFE AND EFFECTIVE USE OF THIS PRODUCT.

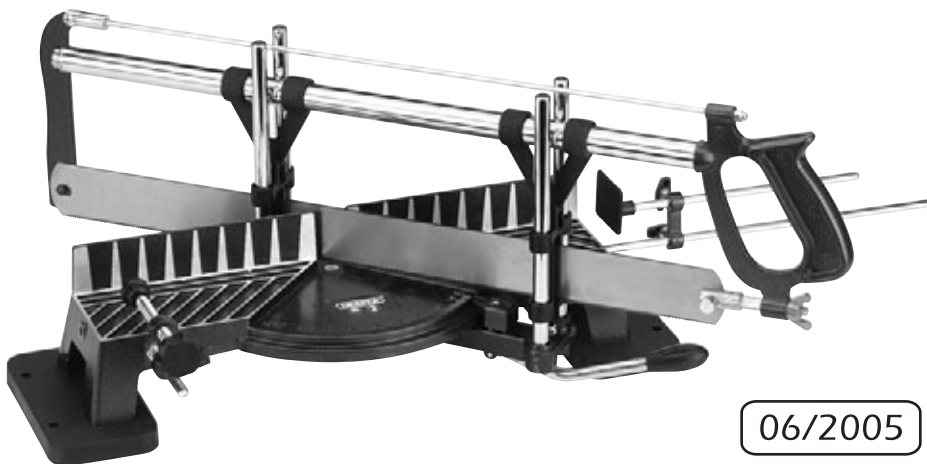

CE

06/2005

DRAPER[®]

GENERAL INFORMATION

This leaflet has been compiled by Draper Tools and is an integrated part of the product with which it is enclosed and should be kept with it for future references.

This leaflet describes the purpose for which the product has been designed and contains all the necessary information to ensure its correct and safe use. We recommend that this leaflet is read before any operation or, before performing any kind of adjustment to the product and prior to any maintenance tasks. By following all the general safety instructions contained in this leaflet, it will ensure both product and operator safety, together with longer life of the product itself.

All photographs and drawings in this leaflet are supplied by Draper Tools to help illustrate the operation of the product.

Whilst every effort has been made to ensure accuracy of information contained in this leaflet, the Draper Tools policy of continuous improvement determines the right to make modifications without prior warning.

- ① Vice clamp assembly.
- ② Length stop assembly.
- ③ Cut depth stop.
- ④ Cut depth stop screws.
- ⑤ Base.
- ⑥ Base socket head screws.
- ⑦ Pre-set angle arm.
- ⑧ Pivot pin.
- ⑨ Cursor screw.
- ⑩ Cursor.
- ⑪ Blade tensioning nut.
- ⑫ Pivot screw.
- ⑬ Saw table.
- ⑭ Saw frame handle.
- ⑮ Saw frame guide bar carriers.
- ⑯ Saw blade.
- ⑰ Saw frame carriers.
- ⑱ Saw frame assembly.

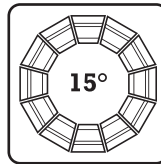
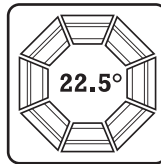
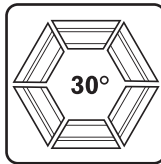
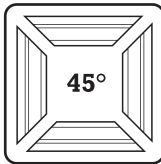
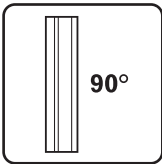
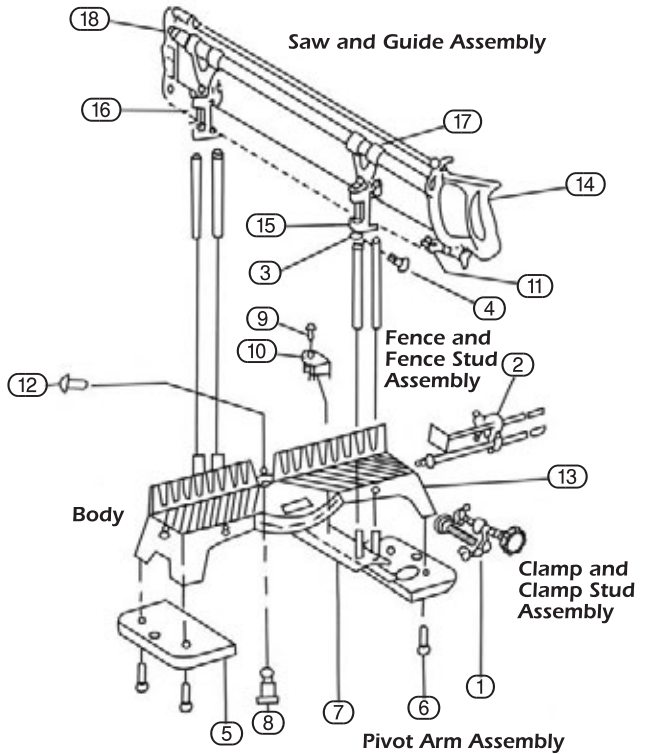

IMPORTANT WARNING

- After assembly, test the angles with some scrap timber to ensure the machine is assembled correctly and cutting true.
- To get the best use from this mitre saw ensure that:-
- The saw blade is tensioned sufficiently to avoid "whip" which will cause the blade to deviate from a true cut.
- The blade is in line and central to the frame.
- The workpiece is square and true to the base casting.
- Blade tension is released after use.
- You read the instruction leaflet supplied thoroughly before use.