

Clinker **XL**

Owners Manual 750mm & 900mm Tile Cutters



Read manual before use. Keep hands arms and face clear of blade whilst in use. Always have safety guard in place when machine is switched on at the mains. Always wear Vitrex protective equipment when using hand or power tools.

PRODUCT DESCRIPTION

Clinker XL is a professional heavy duty tile cutter with a spring loaded base for shock absorbing effect. The machine has a large, graduated swivelling cutting guide and an extendable arm for supporting larger format tiles. The ball bearing scoring block allows for smooth, high precision cutting with a simple single action 'score & snap' cutting process. When moving the machine, use the carrying handle and wheels for ease of transport.

This manual must be kept in a safe place so that the information contained is always available. This operating manual must accompany the tile cutter if it is transferred to somebody else.

We do not accept any liability for accidents or damage arising from ignoring this manual and the safety instructions.

EXPLODED TECHNICAL DRAWING

1. Cutting head carriage with ball bearings
2. Carriage support
3. Swivelling cutting guide
4. Big breaking foot
5. Small breaking foot
6. Tungsten carbide cutting wheel
7. Push bar
8. Shock absorbing trays
9. Base
10. Handle
11. Rigid rail
12. Table extensions

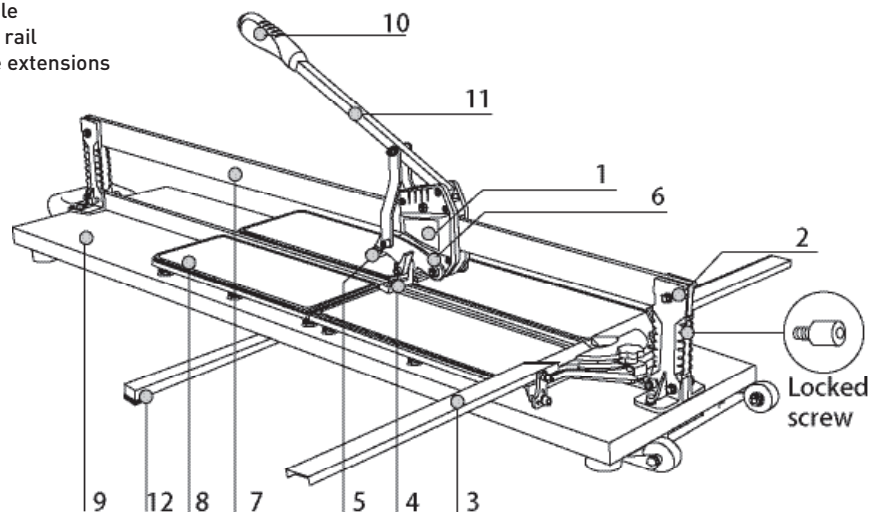

HOW TO USE

Fig 1

Before use, loosen the locking screw in the carriage support with the 5mm hex key provided to unlock the carriage.
Note: When moving or transporting the machine, ensure the carriage is locked.

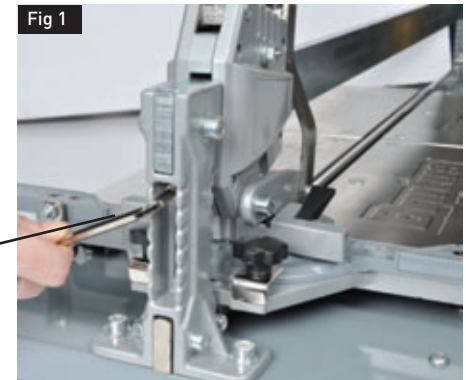

Fig 2

Place the tile on the shock absorbing trays against the cutting guide. With the cutting point aligned, position the carriage and cutting wheel using the push bar.

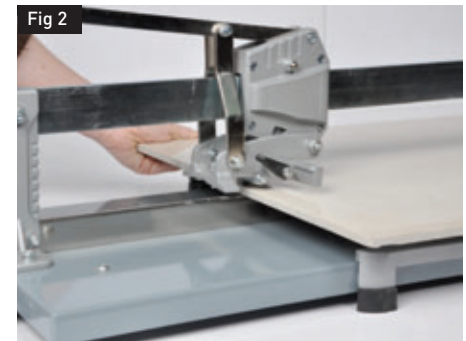

Fig 3 & 4

When diagonal cutting, adjust the swivelling cutting guide to the required degree and then tighten the screws to fix the cutting guide in place

Fig 3

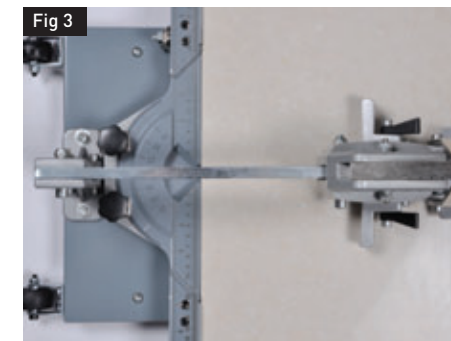
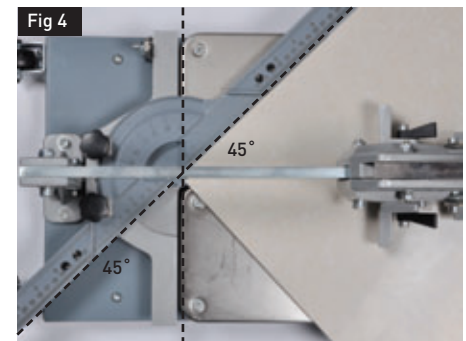

Fig 4



HOW TO USE

Fig 5
When the tile is in position, score the tile by exerting continuous downward pressure on the push bar along the entire length of the tile. After scoring a clear, continuous line along the tile, ensure the tile remains locked in position on the shock absorbing trays.

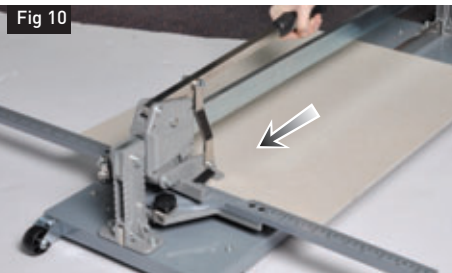
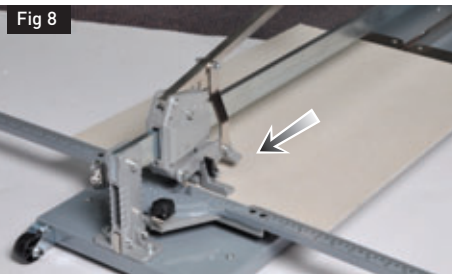

Fig 6
Put the breaking foot in position as indicated in Image 6. Generally, if the tile thickness is less than 10mm, then use the small breaking foot. If the tile thickness is more than 10mm, then use the big breaking foot.



Fig 7 & 8
When using the small breaking foot, gradually increase downward pressure until the tile is cut

Fig 9 & 10
When using the small breaking foot, gradually increase downward pressure until the tile is cut



MAINTENANCE

Remove any dirt or residue from the carriage bar
Note: Do not use any lubrication

Fig 11&12
Replace the cutting wheel if it is worn

Fig 13
Tighten the carriage lever, as indicated

Fig 14
Gradually tighten the carriage, as indicated

Fig 15
Tighten the rigid rail, as indicated

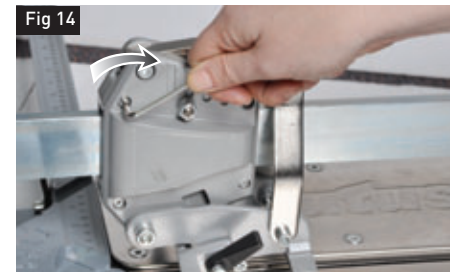
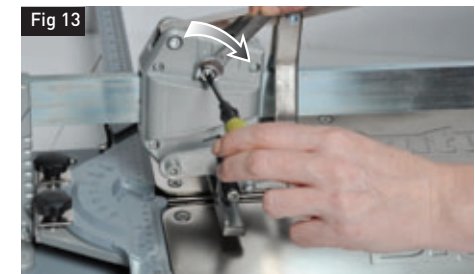
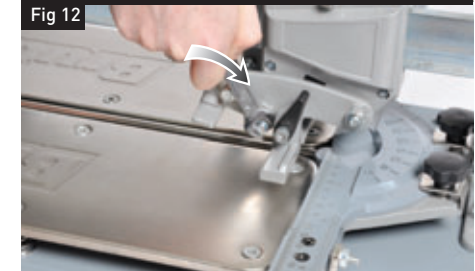
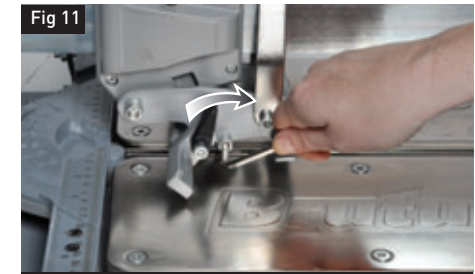

PARTS

REPLACEMENT PARTS AVAILABLE

1. Tungsten Carbide Cutting Wheel
2. Cutting Block
3. Breaking Mechanism
4. Locking Screw
5. Shock Absorbing Tray
6. Spring
7. Spring Bolt
8. Swivelling Cutting Guide
9. Swivelling Cutting Guide Knob
10. Carrying Handle
11. Rubber Feet
12. Tool Kit



TOOLS ENCLOSED

- Double open ended wrench (8mm/10mm)
- Screwdriver
- Hex Key (5mm)
- Hex Key (4mm)
- Hex Key (3mm)



WARRANTY

This tile cutter has been manufactured to a high quality standard. It is guaranteed against faulty materials and workmanship for 2 years from the date of purchase. A faulty machine will either be repaired or replaced free of charge. If a direct replacement is not available, an alternative to the same or greater value/specification will be offered.

This guarantee does not cover machine defects cause by or resulting from:

- a) Misuse, abuse or neglect, b) Trade, Professional or hire use, c) Repairs attempted by anyone other than our authorised repair agent, d) Ingress of foreign objects, substances or accident

This warranty will only be valid if the purchaser promptly registers the product with QEP Co. UK Ltd.

The guarantor is QEP Co. UK Ltd., Everest Road, Lytham St. Annes, Lancashire, FY8 3AZ, Tel: +44(0)1253 789180 (Registered No. 04988177 England)

Claims Procedure:

Any claim made under this warranty should be made directly to QEP Co. UK Ltd. The claim should be made in a letter stating the following information:

- Product purchased
- Date of purchase
- Proof of purchase
- Place of purchase
- Details of the problem leading to the claim

Please ensure a copy of everything sent is retained. This warranty is offered as an extra benefit. The guarantee is only available in the UK and does not affect your statutory rights. The warranty period commences from the date of purchase. Products must be registered within 30 days of purchase. Registration for warranty is confirmed only when a letter of confirmation is sent by QEP Co. UK Ltd.



To validate your warranty you must fully complete this form

Owners Name:

Owners Address:

Postcode:

Telephone Number:

Email:

Date of Purchase:

Model Purchased:

Owners Signature:

Date:

Return completed form to:

Vitrex Clinker XL Warranty, Everest Road, Lytham St. Annes, Lancashire, FY8 3AZ

Vitrex 
Sign of a professional job

Q.E.P. Co. UK Ltd
Everest Road
Lytham St Annes
Lancashire
FY8 3AZ
Tel +44 (0) 1253 789 180
www.vitrex.co.uk

QEP Co. UK Ltd. is committed to a continuous program of product improvement. Consequently, please be advised that specifications, performance, appearance and dimensions of QEP/Vitrex products are subject to change without notice. For more up-to-date information about our range of products, please contact our Customer Service Office on +44 (0)1253 789180 or your local distributor.

brand of **QEP**