

## Assembly Instructions

### Before assembly

- We recommend that time is taken to read the instructions before starting assembly, then follow the easy step by step guide. The instruction sheet is only a guide to the assembly. Certain items may not be shown to scale.
- Check all components prior to assembly
- This product should be assembled by no less than two people.
- Some of the components may have sharp edges wear protective work gloves while handling components.
- Never attempt to erect the assembly in high winds.
- Drill components where indicated.



### Recommended tools for assembly

- Electric drill/screw driver
- Cross head screwdriver bit
- Hammer
- Sharp knife
- Hacksaw
- 3mm diameter drill bit
- 12mm diameter drill bit
- Spirit level
- Silicon sealant
- Step ladder



**Dimensions**

Overall external  
 Height = 2220mm  
 Width = 2130mm  
 Depth = 2700mm

Footprint  
 Width = 1980mm  
 Depth = 2050mm

Min. base area  
 Width = 2080mm  
 Depth = 2150mm

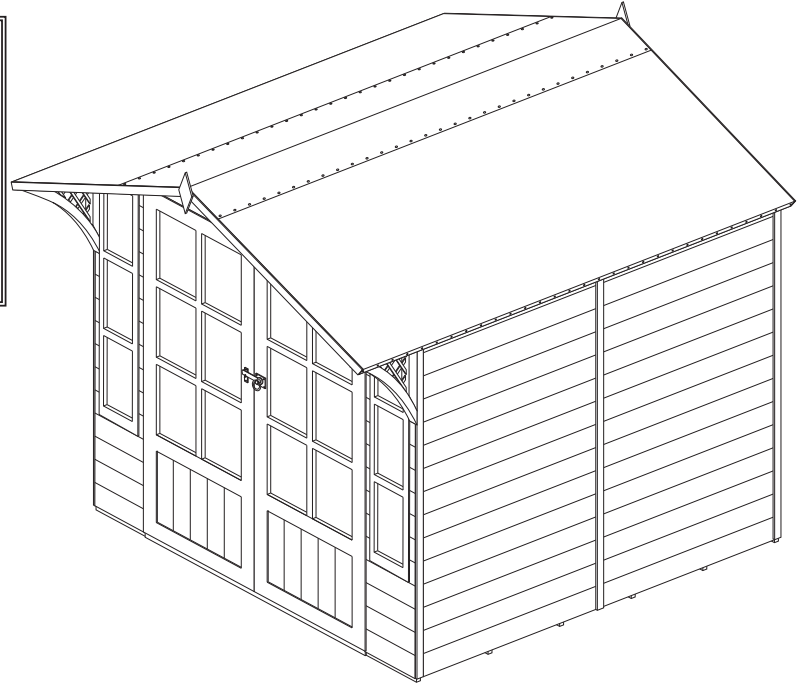

No.	Components	Qty.
1	Floor section	2
2	Plain wall panel	6
3	Front window panel	2
4	Front window frame	2
5	Left door	1
6	Right door	1
7	Apex panel	2
8	Large roof panel	4
9	Small roof panel	2
10	Front/rear roof rafters (35 x 29 x 1070mm)	4
11	Roof purlin (36 x 29 x 2050mm)	4
12	Coverstrip (48 x 12 x 1690mm)	7
13	Kick strip (38 x 12 x 1360mm)	1
14	Lattice wing panel	2
15	Door glazing (372 x 264mm)	12
16	Window glazing (190 x 370mm)	6
17	Roof felt roll (2.8m)	3
18	Bargeboards (48 x 12 x 1150mm)	4
19	Apex cover (110 x 12 x 1990mm)	1
20	Door beading top/bottom (14 x 10 x 555mm)	4
21	Door/window beading TR/BL* (14x10x 380mm)	8
22	Door/window beading TL/BR* (14x10x 380mm)	8
23	Door/window beading middle (14x10x 390mm)	8
24	Door vertical spar (44 x 10 x 360mm)	6
25	Door horizontal spar (44 x 10 x 537mm)	4
26	Window beading top/bottom (14 x 10 x 195mm)	4
27	Window horizontal spar (44 x 10 x 537mm)	4
28	Finial	2

\*TR/BL = Top right/bottom left  
 TL/BR = Top left/bottom right

No.	Fixing Kit	Qty.
29	Door frame beading (10 x 10 x 100mm)	1
30	Latch door handle kit	1
31	Door hinge	6
32	Tower bolts	2
33	70mm screws	2
34	63mm screws	8
35	50mm screws	47
36	35mm screws	58
37	25mm screws	30
38	19mm black round head screws	18
39	40mm nails	41
40	25mm panel pins	141
41	10mm felt nails	148

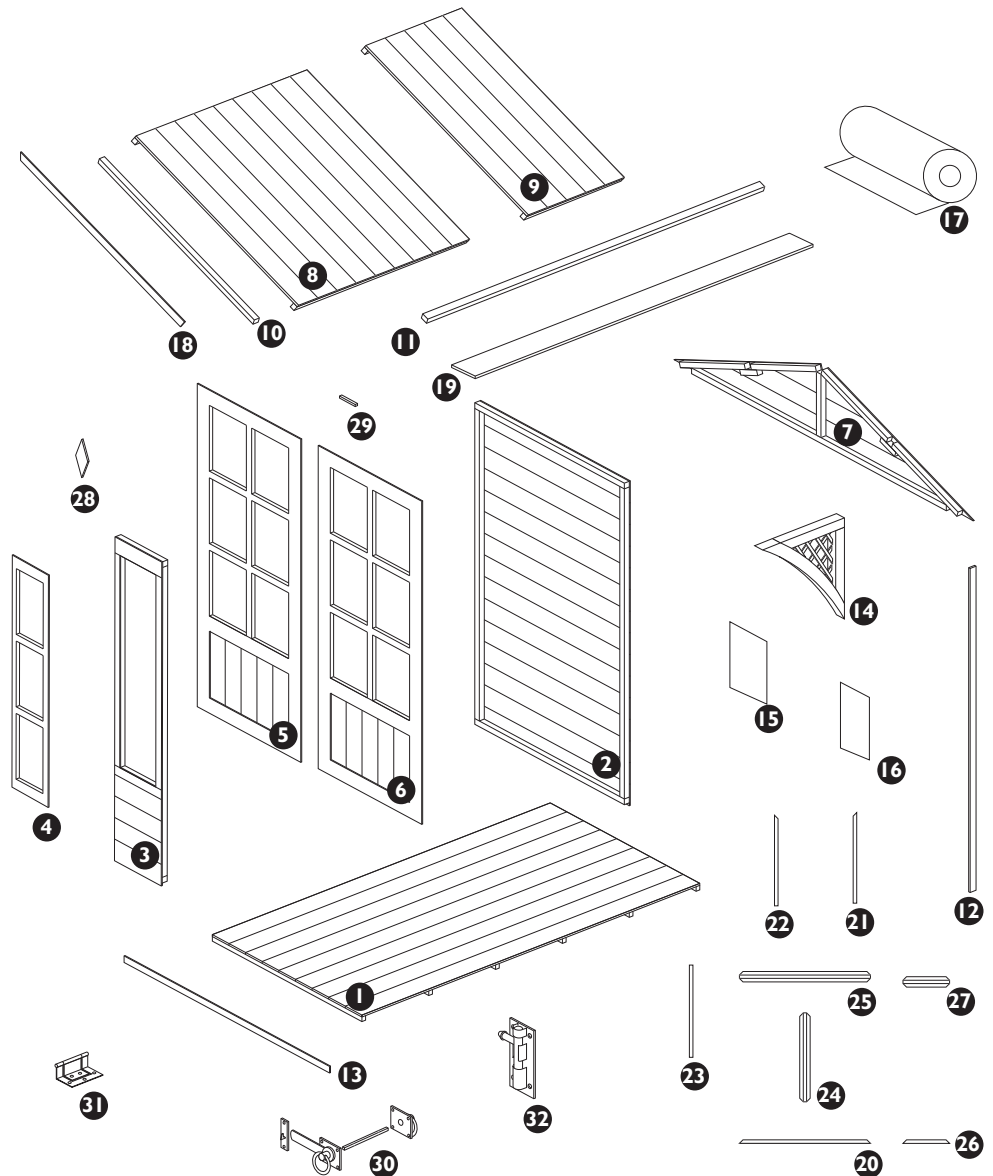

## 1. Floor

Prepare a level area for the summerhouse to sit. Attach at least three wooden or similar bearers of size 50 x 50 x 2050mm to each of the floor sections (not supplied in kit). Place the two sections on the floor butted up next to each other, as shown in the diagram.



**Important**  
When laying the floor, it is important to note the T&G floor boards must run from the front of the building to the back.

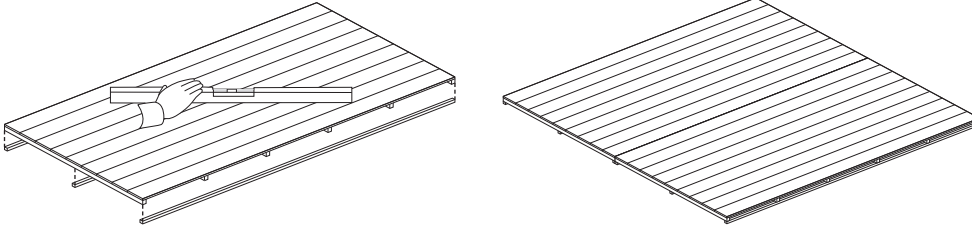

### Important note

ensure ground contact is avoided and air is able to circulate underneath the building.

Placing the building on a concrete pad or slab base is acceptable provided that the building is not allowed to sit in pooled water during wet conditions.

If the building is to sit on soil or grass it **MUST** be erected on pressure treated wooden 50mm x 50mm or similar bearers (**These are not supplied in the kit**).

Rowlinson Garden Products recommend using pressure treated bearers with all buildings on any type of base.

## 2. Window frames and glazing

Place the front window frame into the opening of the front panel. Drill four pilot holes on the inside of the frame as shown and secure the frame in place using 4 x 50mm screws. Glazing the windows and doors can be done once the building is assembled. However it may be easier to install the glass whilst the panels are laid flat on the ground. Working on one panel at a time lay each one flat on the ground. Apply a small amount of waterproof silicon sealant to the frame, around each glazing rebate. Carefully place a piece of glazing into each rebate. When all glass is in place, fit the outer edge beading first, then the horizontal spars followed by the vertical spars. Attach each beading and spar piece with 2 x 35mm panel pins.

View from rear of panel

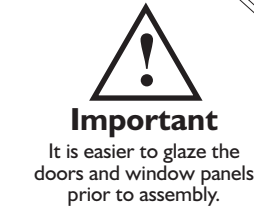
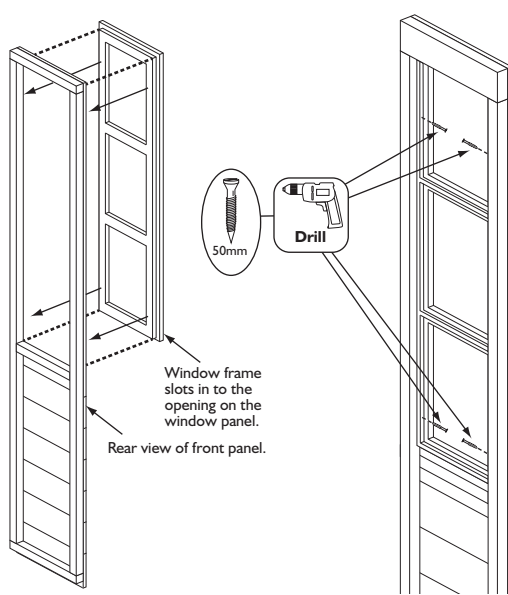

Fit the glass. With the glass in place fit the outer edge beading first. Pin each beading strip with 3 x 25mm panel pins.

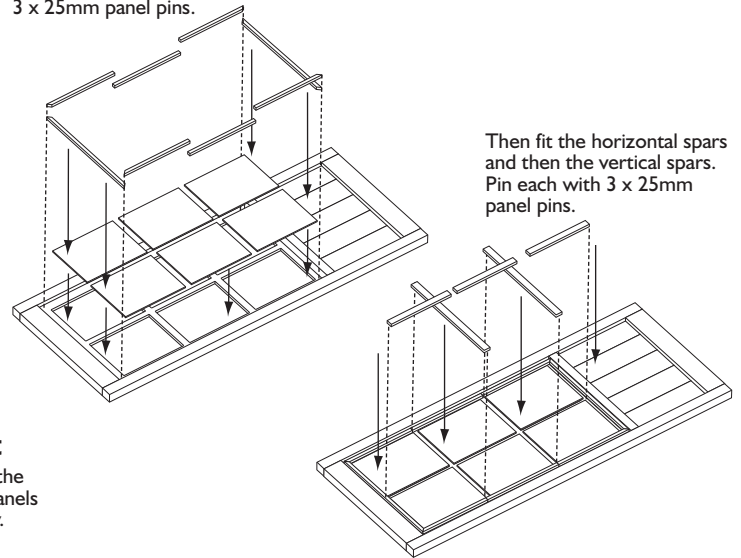

Then fit the horizontal spars and then the vertical spars. Pin each with 3 x 25mm panel pins.

## 3. Wall panels

Position two plain panels on the floor to create the rear left corner as shown. Note how the panel frames sit on the floor with the panel cladding overhanging the floor edge. Ensure square and secure the two panels together using 3 x 50mm screws. Screw through the frame of the side panel into the frame of the back panel. Position another panel on the back wall next to the other, ensure level and secure them together using 3 x 50mm screws, screw through the frame of the first panel into the frame of the second. Continue adding the rest of the panels as shown in the diagrams.



It is recommended to drill pilot holes for these screws with a 3mm drill bit before assembly.

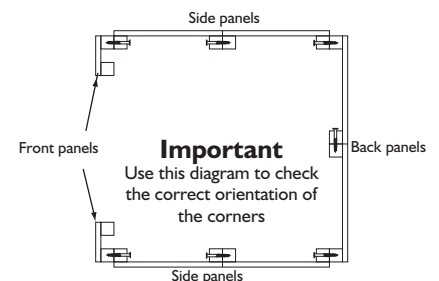
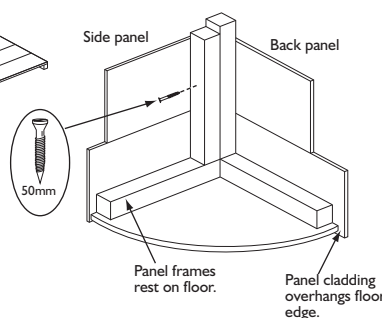
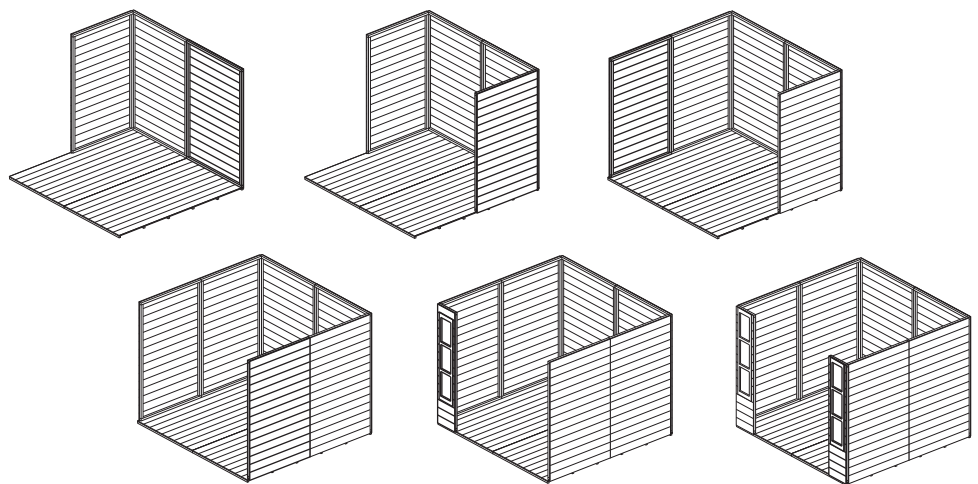
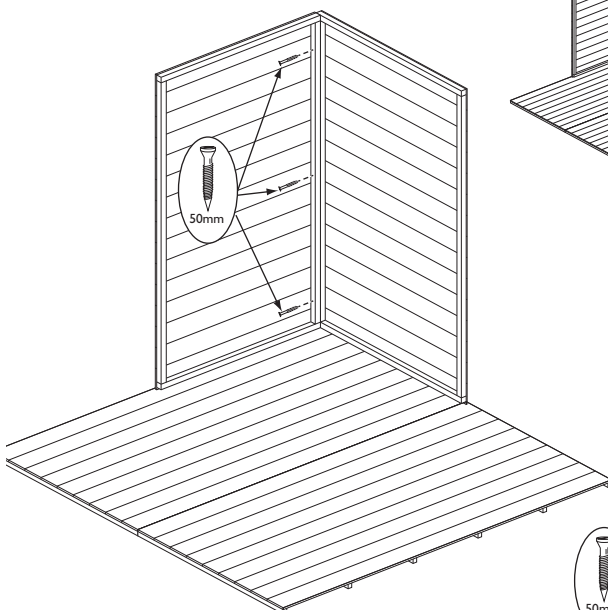

#### 4. Apex panels

Place the back apex panel on top of the back wall, make sure the bottom shiplap board of the apex panel fits correctly into the top shiplap board of the back wall. Secure using 2 x 50mm screws, screw up through the top frame of the back panel into the bottom frame of the apex panel. Repeat for front apex using 2 x 70mm screws. Attach the door frame beading to the front apex using 3 x 25mm panel pins. Secure it to the bottom of the framing, up against the cladding about 560mm from the right front panel as shown below.

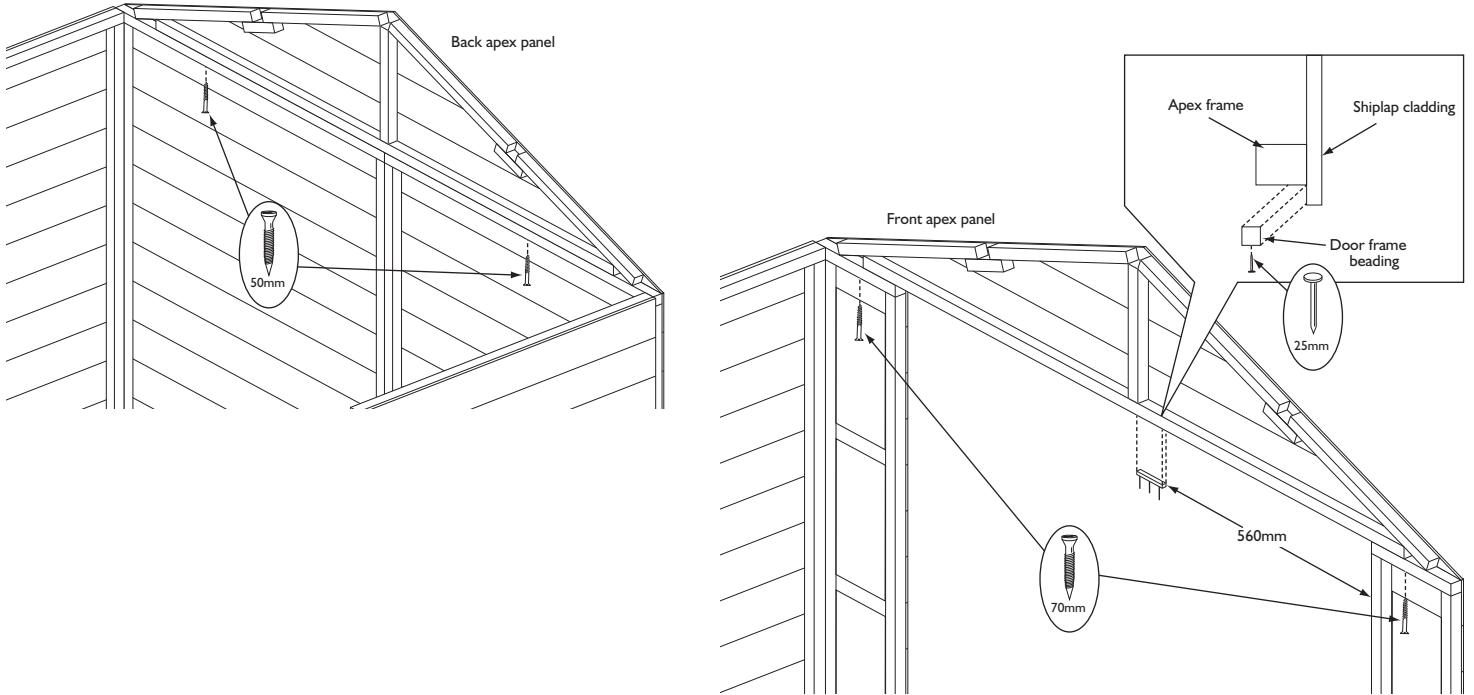

#### 5. Securing walls to floor

Fit the kick strip centrally to the front edge of the floor using 4 x 40mm nails. Ensure the panels are sitting square on the floor. Secure them by screwing through the panel frames into the floor using 8 x 60mm screws.

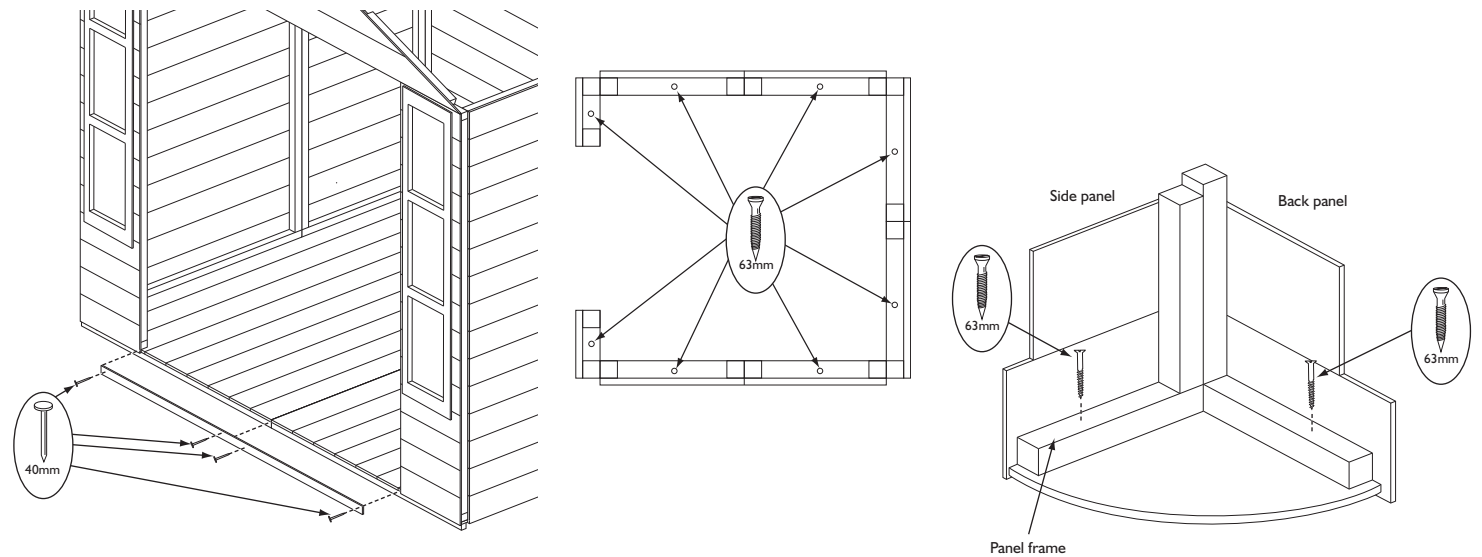

#### 6. Roof purlins

Insert the four roof purlin into the rebates in the apex panels. Fix in place using 1 x 50mm screw at both ends of each purlin. Screw through the purlin and into the frame of the apex panels.

 It is recommended to drill pilot holes for these screws with a 3mm drill bit before assembly.

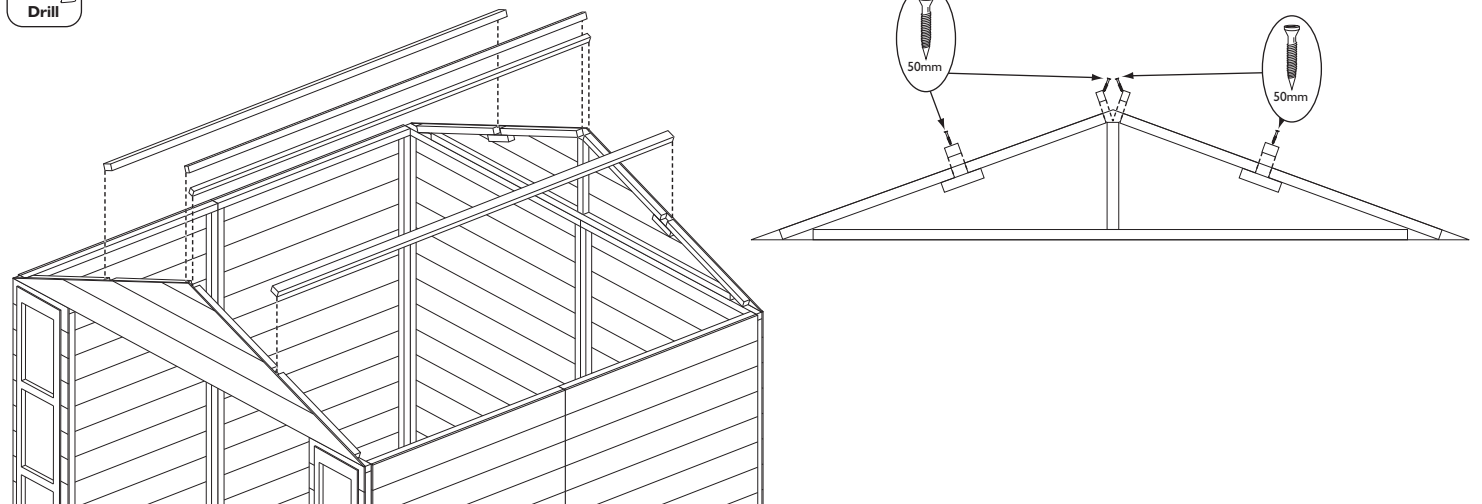

## 7. Roof

Starting at the back lift a large roof panel on to one side of the building, hooking the roof batten over the upper roof purlin. With the panel overhanging the back of the building by 55mm secure down using 6 x 35mm screws, screw through the roof panel into the purlins and top frame of the wall panels. Working towards the front add a small size roof panel and then a large roof panel, securing each one using 6 x 35mm screws. Repeat for the other side of the roof. To the front and rear roof panels fit the front and rear roof rafters. Position between the pre-fitted batten and purlin. Ensure flush with the edge of the roof panel and fix in place using 4 x 35mm per rafter. Inside the building fit the apex cover to the two centre purlins using 6 x 35mm screws.



It is recommended to drill pilot holes for all screws in this section with a 3mm drill bit.

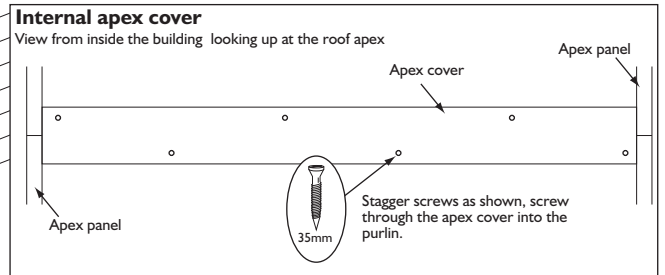
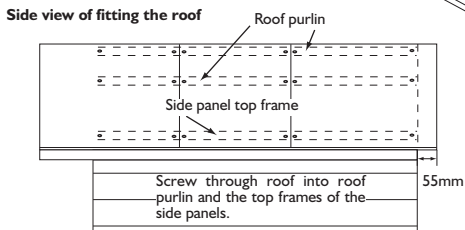
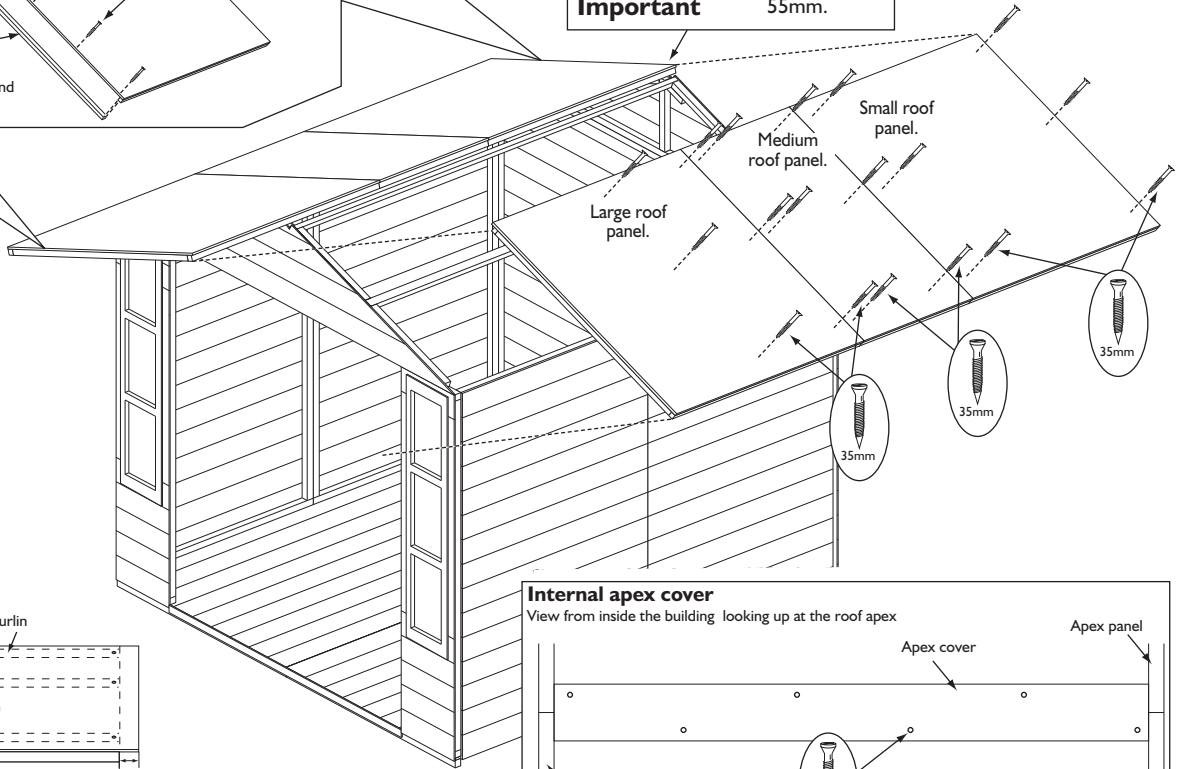
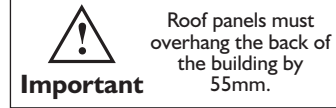
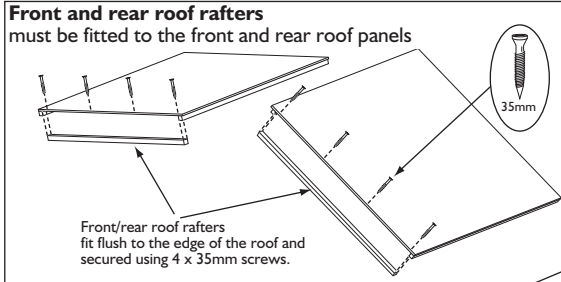
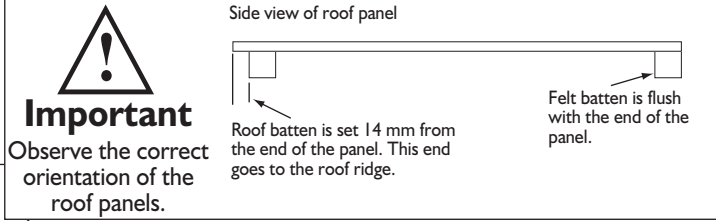

## 8. Lattice wing panels

Position a lattice wing side panel in the corner of the roof and front panel. Ensure the wing is flush to the outer edge of the building and secure using 2 x 50mm screws, screw through the frame of the wing into the front panel, fix to the roof felt batten using 2 x 50mm screws as shown. Attach the other wing panel in the same way.



It is recommended to drill pilot holes for these screws with a 3mm drill bit before assembly.

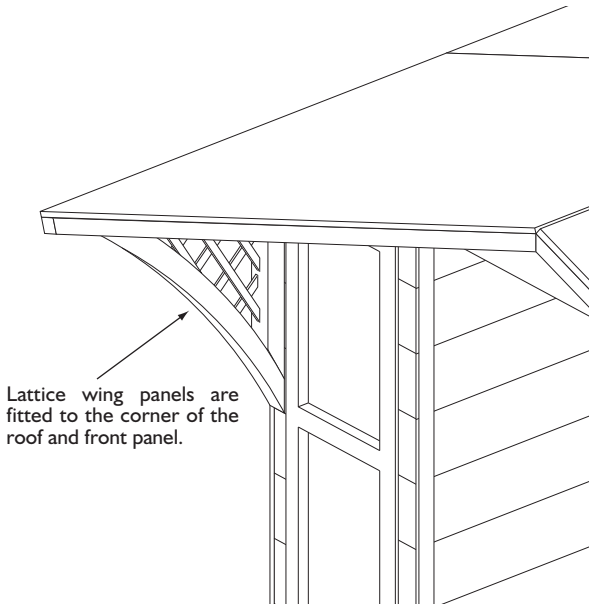
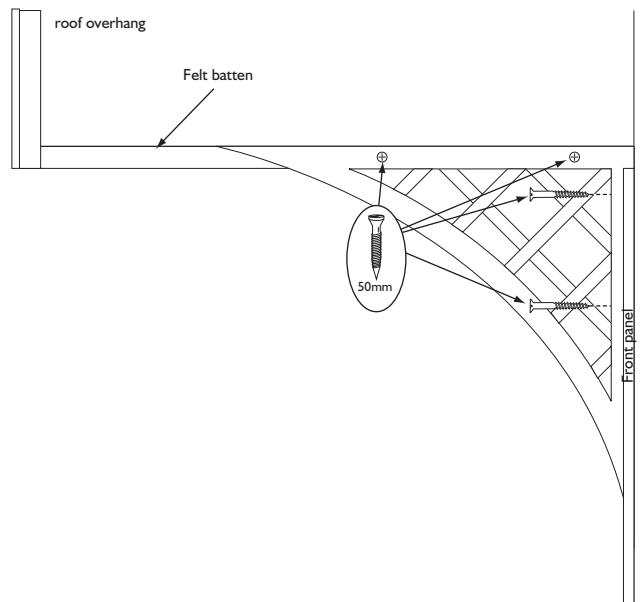

## 9. Roofing felt

Place a length of felt over half of the roof. At the front and along the lower edge of the roof leave an overhang of felt of at least 45mm to cover the felt battens. Fold down the felt along the lower edge and secure to the felt batten using 30 x 10mm felt nails evenly spaced. Tension the felt over the roof and secure along the upper edge using 6 x 10mm felt nails. Repeat this for the second piece of felt on the other half of the roof. Once the two pieces of felt are in place take the 3rd felt piece and place over the apex of the roof making sure it sits centrally over the roof ridge and overlaps the other two felt pieces, attach using 30 x 10mm felt nails evenly spaced, along the two long edges of the ridge felt. Dress down the ends of the felt and at the front attach to the felt batten with 6 x 10mm felt nails. Repeat at the back of the building. Once secured trim off excess felt.

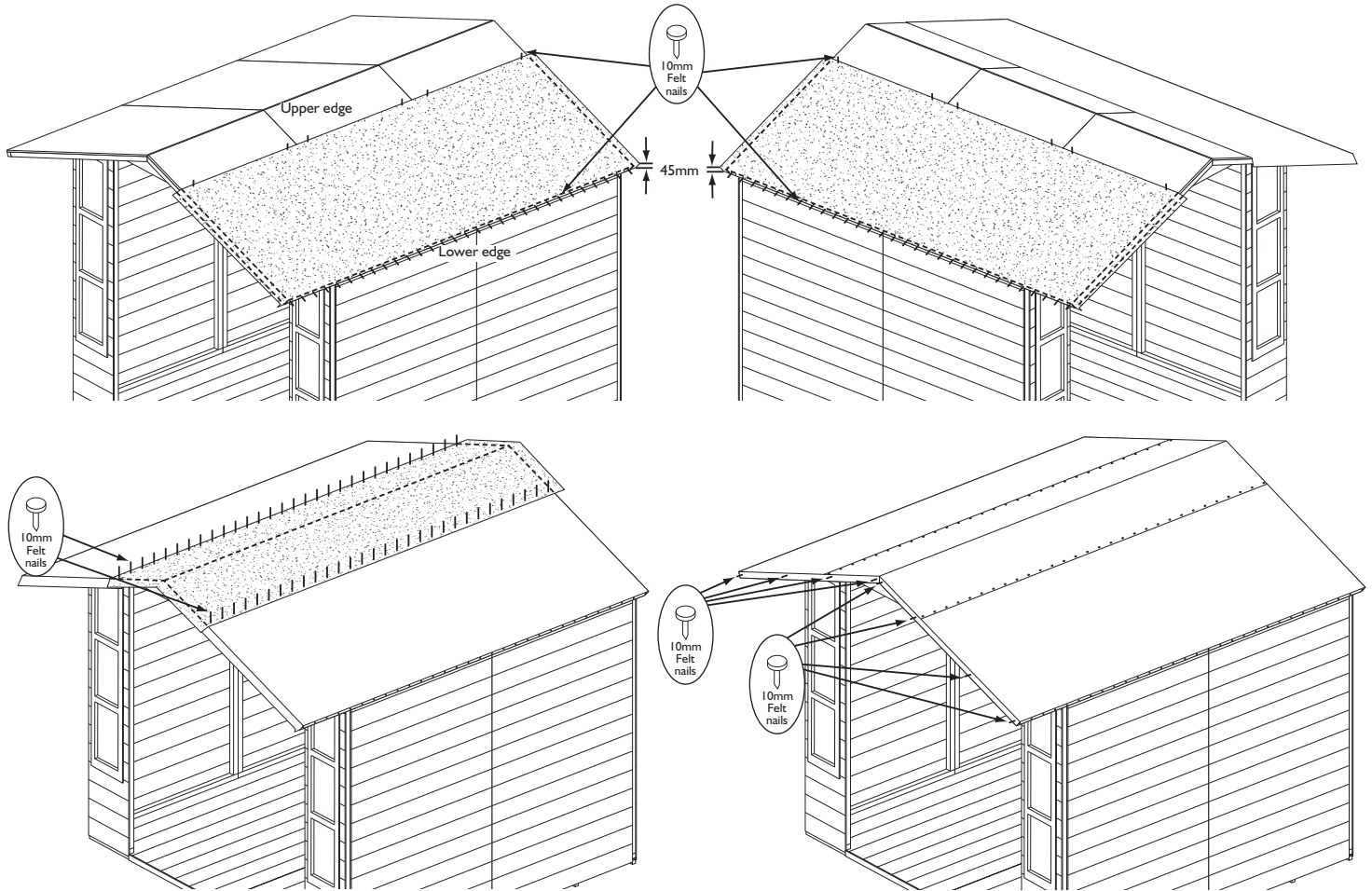

## 10. Coverstrips, bargeboards and finials

Fit a Coverstrips into each corner, attach using 3 x 40mm nails per strip. The remaining three are used to cover the panel joins, one on each side and the back, attach using 3 x 40mm nails per strip. Attach bargeboards at the front so that the top edge is flush with the roof line and the two boards meet evenly in the middle secure using 3 x 40mm nails per board. Attach a finial centrally over the join between the two bargeboards using 2 x 40mm nails. Fit the remaining bargeboards and finial to the back of the building in the same way.

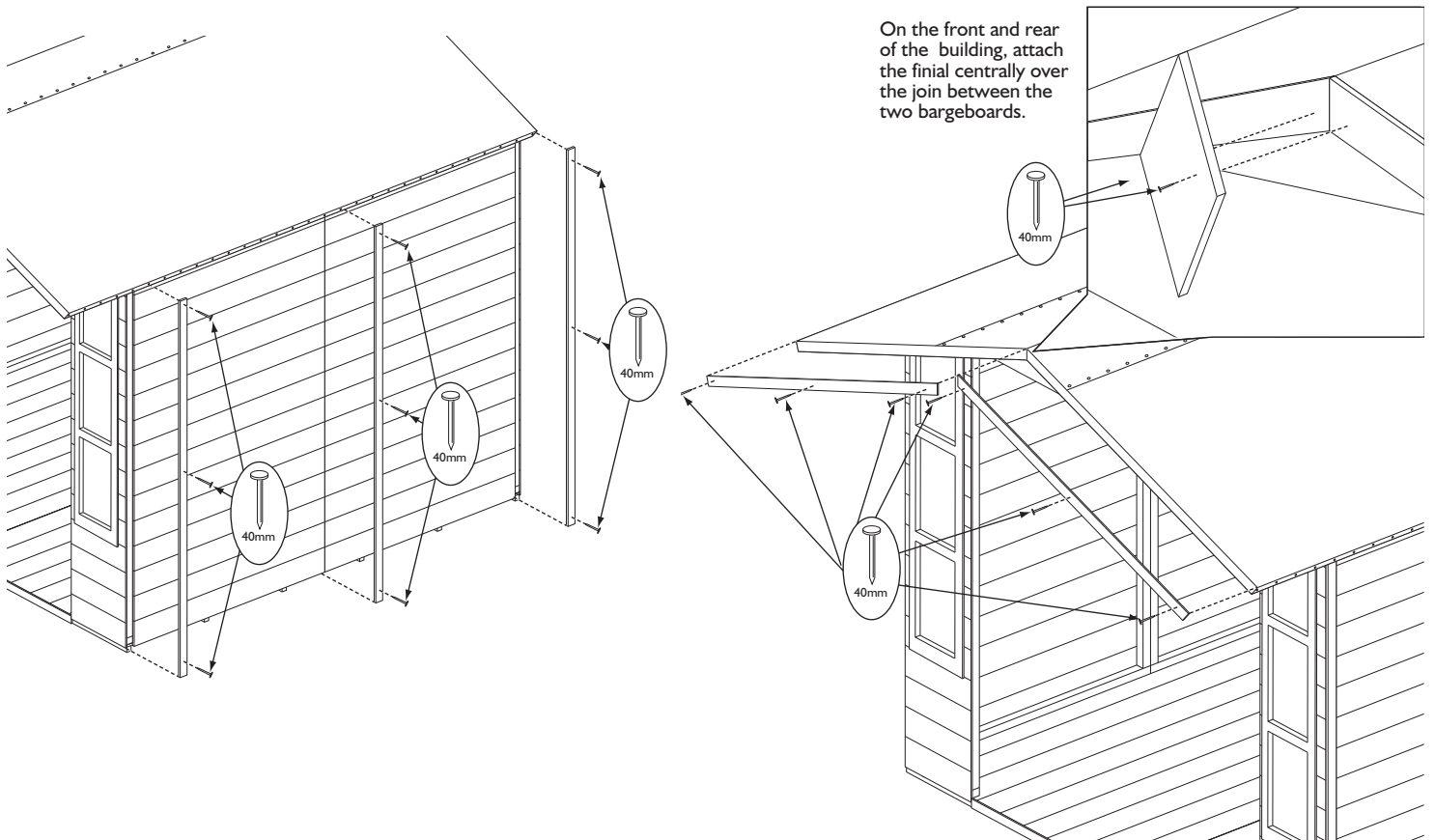

## 11. Hanging the doors

Fit three hinges to the long rebated edge of each door. Position them 150mm from the ends and one centrally between the other two. Attach the small tab of each hinge using 2 x 25mm screws. Open the hinges and fit them around the door frame, adjust the door to the correct height and fix the hinges to the door frame using 3 x 25mm screws per hinge. Attach the tower bolts to the inside of the left door as shown using 4 x 19mm round head screws per bolt.

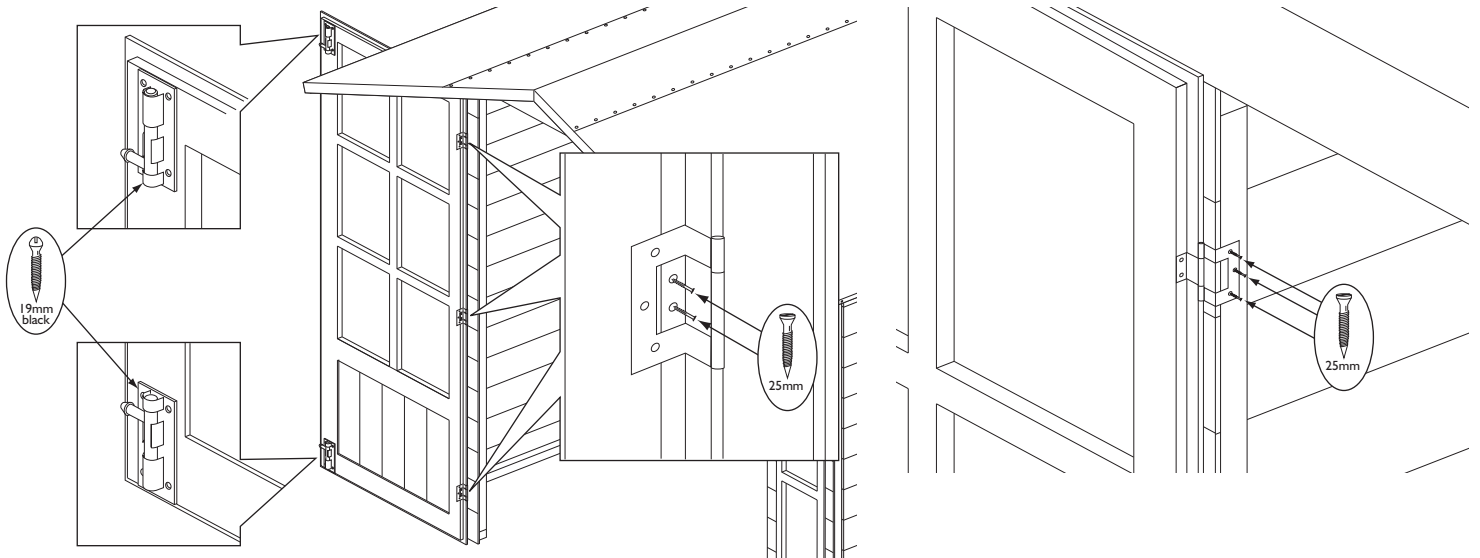

## 12. Latch door handle

Position the Latch door handle about half way up the door. Mark the position of the four holes on the door. Remove the latch and draw two lines connecting diagonally opposite corners, drill a 12mm diameter hole where the two lines cross. Put the latch bar in the hole on the back of the latch, then reposition the latch (putting the bar through the drilled hole) and attach using 4 x 19mm black screws. On the other side of the door fit the inside door handle to the bar and then using 4 x 19mm black screws attach the handle to the door. On the front of the other door position the latch holder so that it holds the latch horizontal. Once in position attach to the door with 2 x 19mm black screws. With the doors shut, drop the lower tower bolt and mark where it touches the floor. Drill a 12mm hole in the floor for the bolt to fit in.

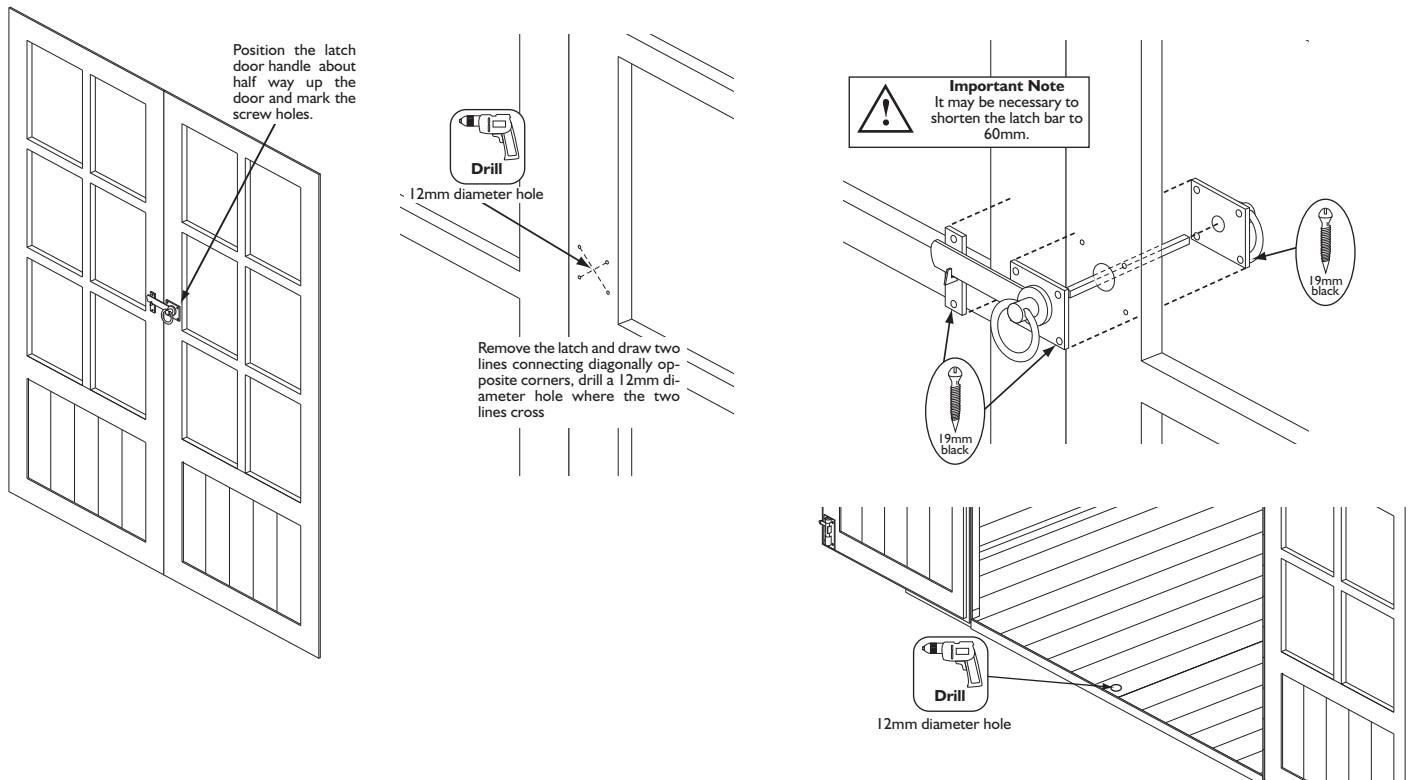

## Important information

Shiplap buildings come ready stained but this is only a preparatory treatment. To **VALIDATE** the guarantee, the building must be properly treated with a recognised external wood preserver **WITHIN 3 MONTHS** of assembly and **RE-TREATED ANNUALLY** thereafter. The building must also be erected on 50mm x 50mm treated wooden or similar bearers (These are not supplied with the kit.) Ground contact must be avoided.

### Timber Information.

As timber is a natural material, there are certain weather conditions that may affect the materials properties. In times of excessive dry spells the material may lose some of its internal moisture causing a certain degree of shrinkage on a panel and in periods of excessive rain there will be a certain amount of swelling throughout the wooden panels. This process can not be avoided. If you have problems with certain boards shrinking in dry spells try to decrease the amount of direct sunlight on the building or the amount of air passing over the building. During hot spells spray water directly onto the panels with the aid of a garden hose.

If in doubt of any aspect regarding the assembly, use or safety of your summerhouse please contact us :

**Help Line: (Normal Office Hours) 01829 261 121**

**Email: support@rowgar.co.uk**

ROWLINSON GARDEN PRODUCTS LIMITED  
Green Lane  
Wardle Nr. Nantwich  
Cheshire  
CW5 6BN  
[www.rowgar.co.uk](http://www.rowgar.co.uk)

We constantly improve the quality of our products, occasionally the components may differ from the components shown and are only correct at time of printing. We reserve the right to change the specification of our products without prior notice.

**2018 © Rowlinson Garden Products Ltd**