

719181214

# Owner's Manual & Assembly Guide



www.arrowsheds.com

**Model No. DSSCBW  
DSSCBWDI  
DSSCANBW  
DSSCANBWDI**

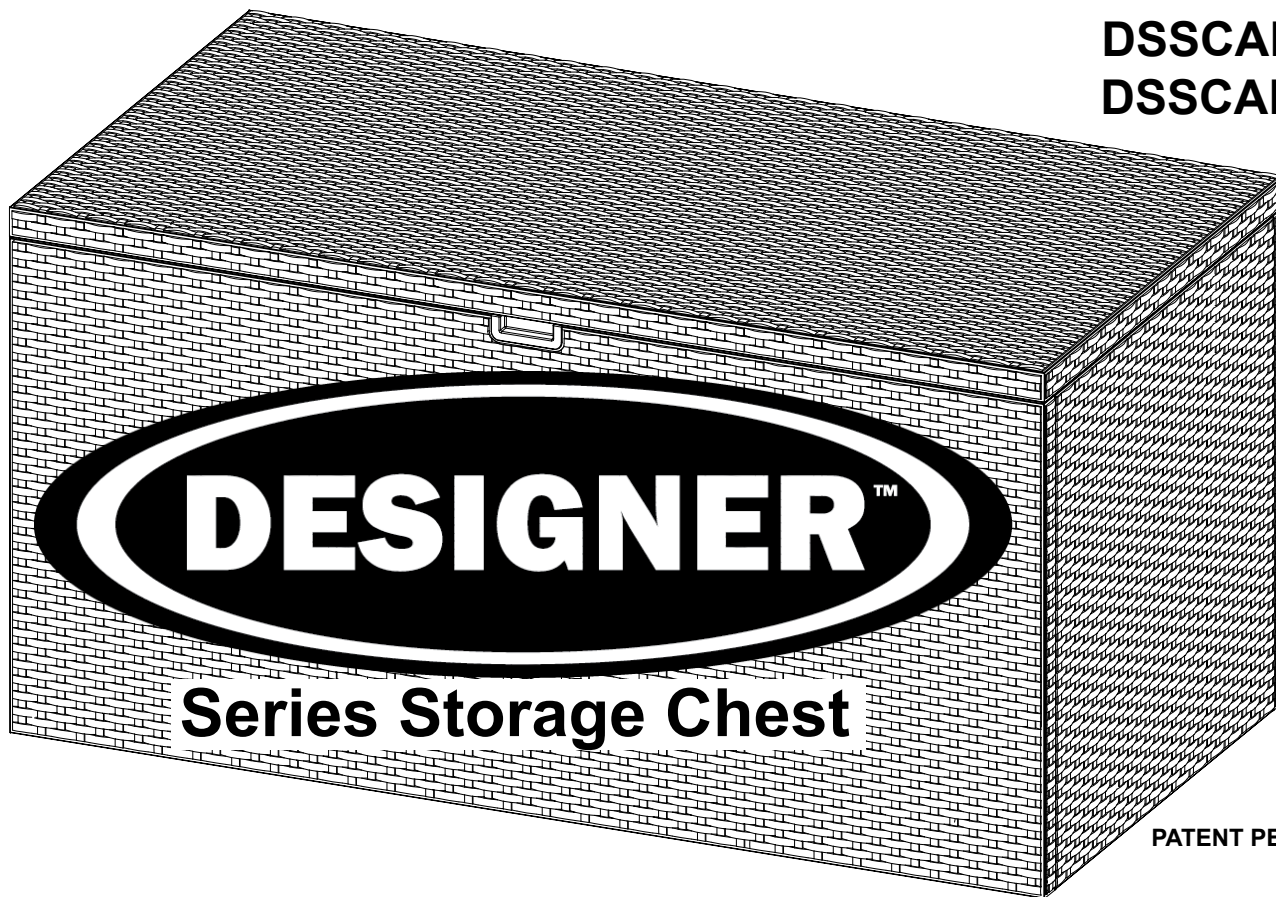

**Customer Service:**  
1-800-851-1085 or  
assist@arrowsheds.com



**caution**  
**sharp edges** \*

Gloves must be worn at all times to reduce risk of injury!



**UNIT DIMENSIONS**

Storage Area		Exterior Dimensions (Lid Edge to Lid Edge)			Interior Dimensions (Wall to Wall)		
		Width	Depth	Height	Width	Depth	Height
10 Sq. Ft.	22 Cu. Ft.	52"	27 3/16"	26 3/16"	50 1/2"	25"	24 11/16"
0,9 m <sup>2</sup>	0,6 m <sup>3</sup>	132,1 cm	69,1 cm	66,5 cm	128,3 cm	63,5 cm	62,7 cm

\* See Inside for Detailed Safety Information.

# BEFORE YOU BEGIN...

**Safety precautions MUST be followed at all times throughout the construction of your Storage Unit!**

## sharp edges



•Care must be taken when handling various pieces of your Storage Unit since many contain sharp edges. Please wear work gloves, eye protection and long sleeves when assembling or performing any maintenance on your Storage Unit.

## always practice proper tool safety

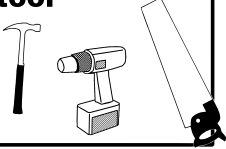

•Practice caution with the tools being used in the assembly of your Storage Unit. Be especially familiar with the operation of all power tools.

## no children or pets at worksite



•Keep children and pets away from the worksite during construction. Do not allow children to help with assembly.

## beware of wind



•Do NOT attempt to assemble your Storage Unit on a windy day. The large panels can catch the wind like a “sail”, causing them to be whipped around making construction difficult and unsafe.

•We recommend two people work together to assemble your Storage Unit. This will make assembly faster and easier.

Reading and following all steps carefully will help make assembly quicker and easier. Before you begin assembly, be sure to confirm that all the parts for your Storage Unit are present using the checklist on pages 3 and 4. If parts are missing or damaged, include the model number of your Storage Unit and contact Customer Service at 1-800-851-1085 or online at [assist@arrowsheds.com](mailto:assist@arrowsheds.com).

## NOT RECOMMENDED FOR STORAGE OF CORROSIVE CHEMICALS OR PRODUCTS

Below is a list of things you will need to assemble your Storage Unit.

### WHAT YOU NEED

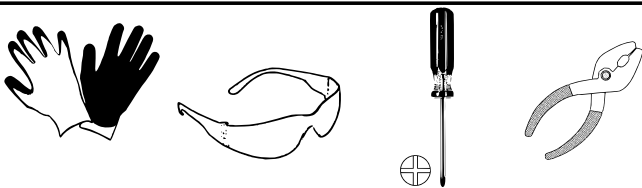

- Work Gloves
- Safety Glasses
- No. 2 Phillips Screwdriver (Magnetic Tip Preferred)
- Pliers

### RECOMMENDED TIME SAVERS



- Power Drill (Cordless, Variable Speed)
- Nut Driver or Wrench
- Awl (to help align holes)

# HARDWARE LIST...

03V

Part No.	Part Description	Qty.	✓ List
AA	M4*16 Cross recessed pan head screw	8	
BB	M4*12 Cross recessed pan head self-tapping screw	56	
CC	M4*12 Cross recessed countersunk head screw	9	
DD	M4*12 Cross recessed countersunk head screw (Black)	4	
EE	M4 Hex Nut	21	
FF	M4*8 Cross recessed pan head screw	8	
GG	Top Air Spring Pedestal	2	
HH	Bottom Air Spring Pedestal	2	
II	Feet M6 x 15	6	
JJ	Air Spring	2	

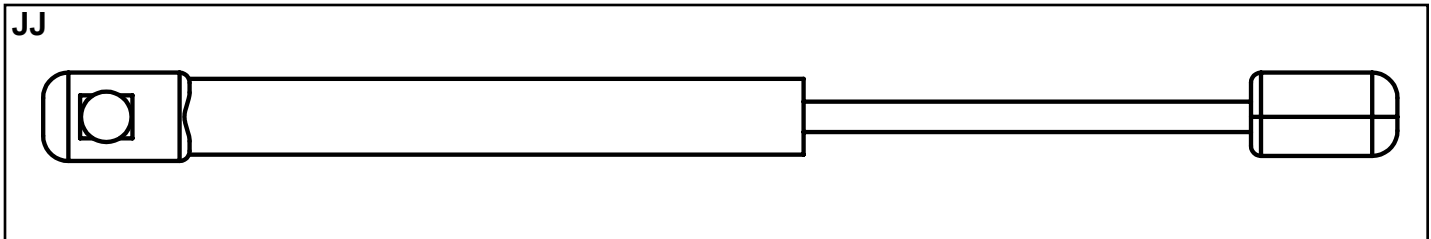
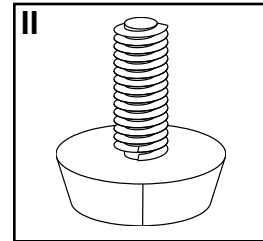
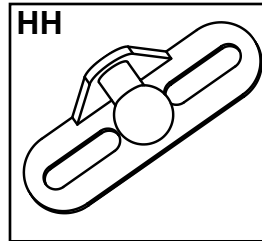
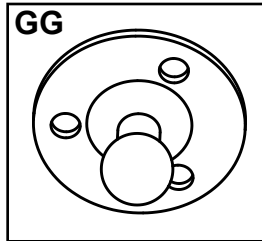
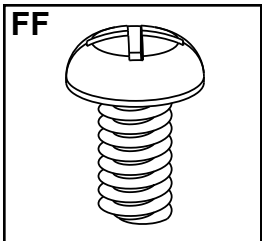
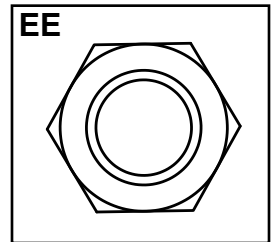
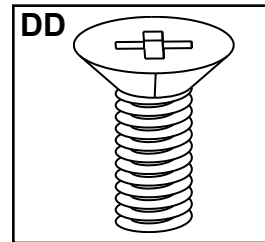
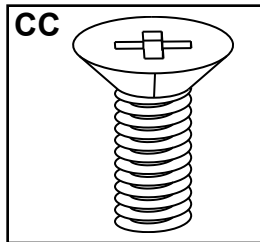
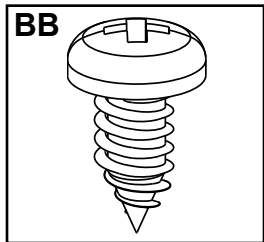
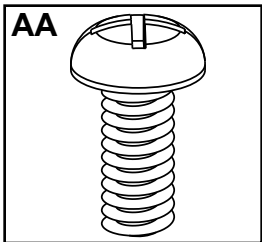

**Confirm that all hardware and parts are present before attempting to assemble your Storage Unit.**

For missing or damaged parts contact Customer Service. Do not return to store.

**Customer Service:**

1-800-851-1085 or [assist@arrowsheds.com](mailto:assist@arrowsheds.com)

# PARTS LIST...

Part No.	Part Description	Qty.	✓ List
A	Lid Panel	1	<input type="checkbox"/>
B	Front Panel	1	<input type="checkbox"/>
C	Back Panel	1	<input type="checkbox"/>
D	Left/Right Panel	2	<input type="checkbox"/>
E	Bottom Panel	1	<input type="checkbox"/>
F	Strength Rib	5	<input type="checkbox"/>
G	Plastic Handle	1	<input type="checkbox"/>
H	Corner Support	8	<input type="checkbox"/>

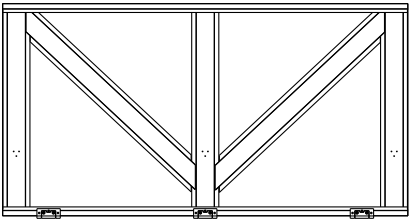

A

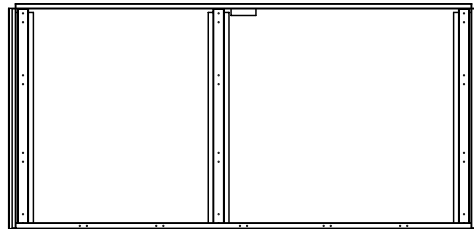

B

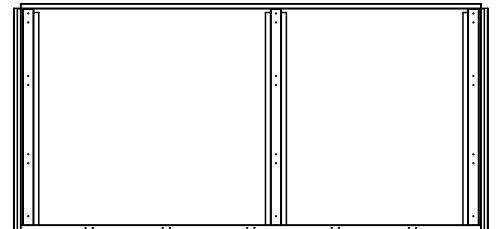

C

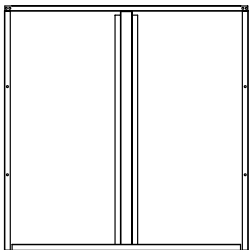

D

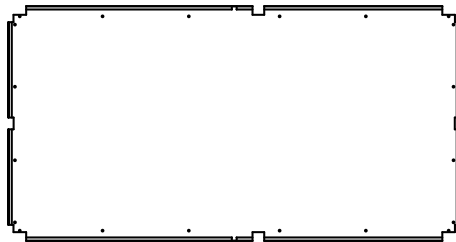

E

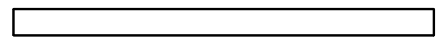

F

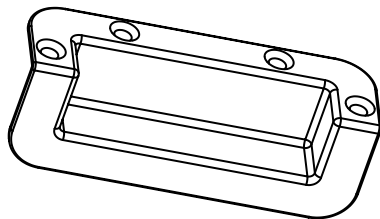

G

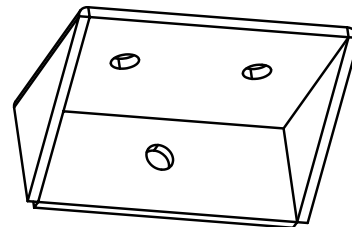

H

# ASSEMBLY BY KEY NO.

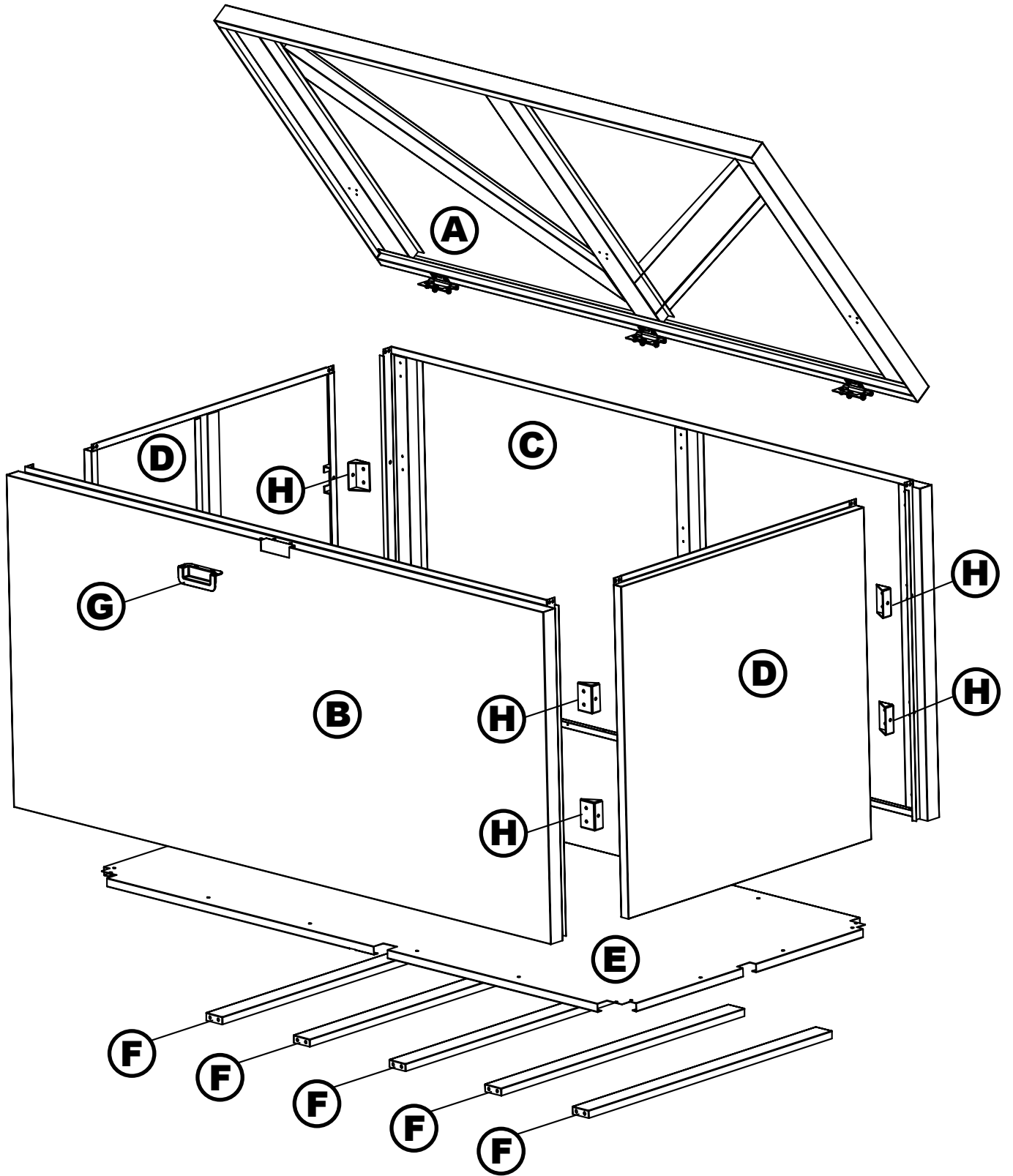

# Step 1

You will need for this page:

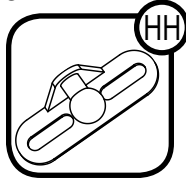
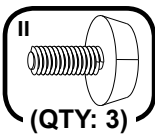
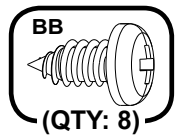

- Back Panel - C (QTY: 1)
- Bottom Air Spring Pedestal - HH (QTY: 2)
- Corner Support - H (QTY: 4)

- 1 Attach the **Bottom Air Spring Pedestal** to the **Back Panel** by using **Screws provided with Bottom Air Spring Pedestal**. Push **Bottom Air Spring Pedestal** downward and tighten **Screws** as shown in Figure A.
- 2 Attach four (4) **Corner Supports** to **Back Panel** using eight (8) **Hardware BB** as shown in Figure B. **DO NOT TIGHTEN SCREWS.**
- 3 Put three (3) **Hardware II** on the bottom of **Back Panel** as shown in Figure C.

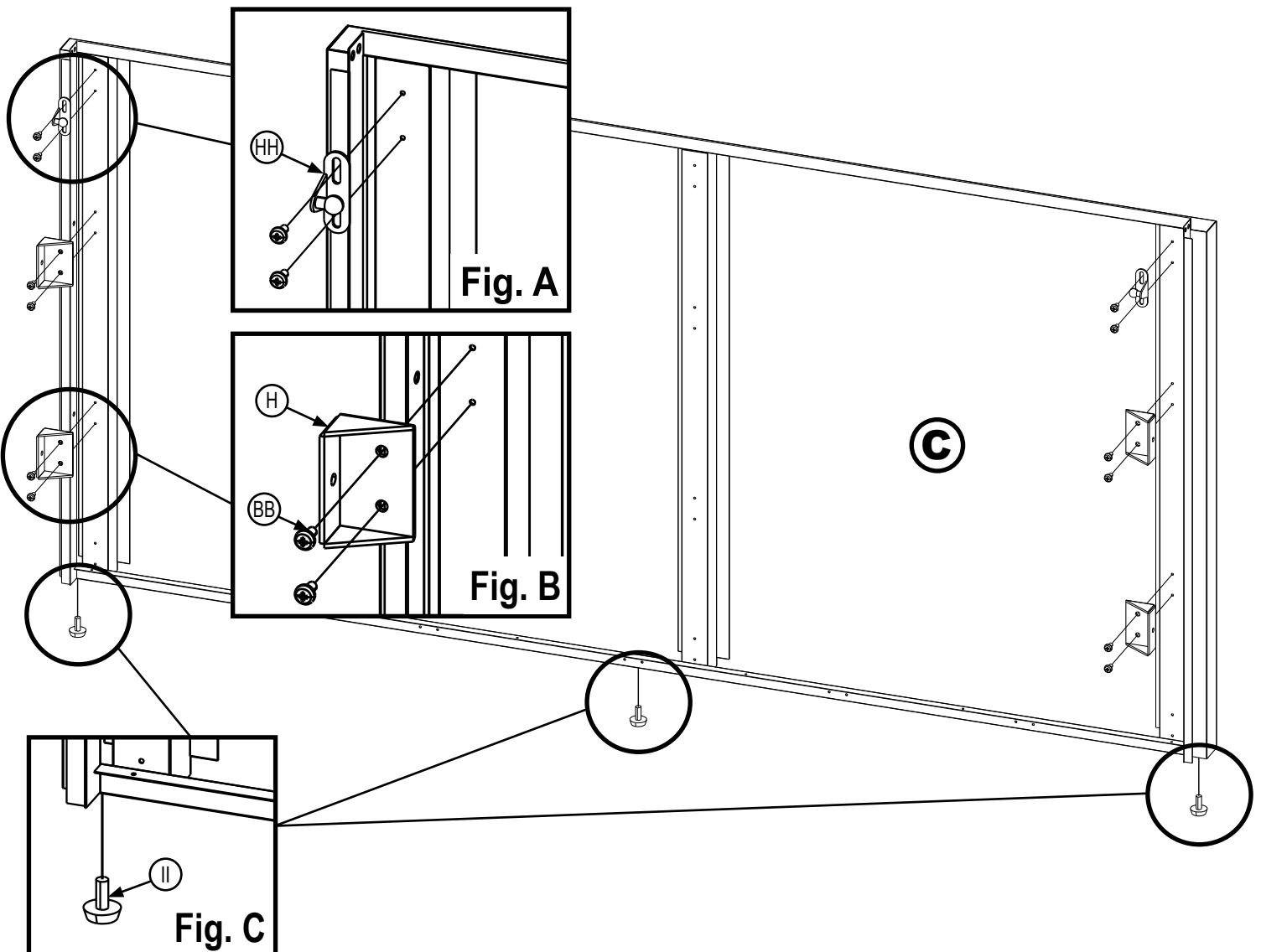

# Step 2

- You will need for this page:**
- Front Panel - B (QTY: 1)
  - Plastic Handle - G (QTY: 1)
  - Corner Support - H (QTY: 4)
  - Hardware DD (QTY: 4)
  - Hardware EE (QTY: 4)
  - Hardware BB (QTY: 8)
  - Hardware II (QTY: 3)

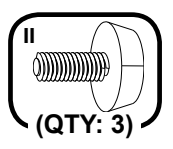
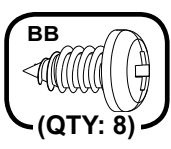
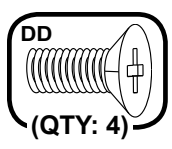

1

Install the **Plastic Handle** on the **Front Panel** using four (4) **Hardware DD** and four (4) **Hardware EE** as shown in Figure D.

2

Attach four (4) **Corner Supports** to **Front Panel** using eight (8) **Hardware BB** as shown in Figure E. **DO NOT TIGHTEN SCREWS.**

3

Put three (3) **Hardware II** on the bottom of **Front Panel** as shown in Figure F.

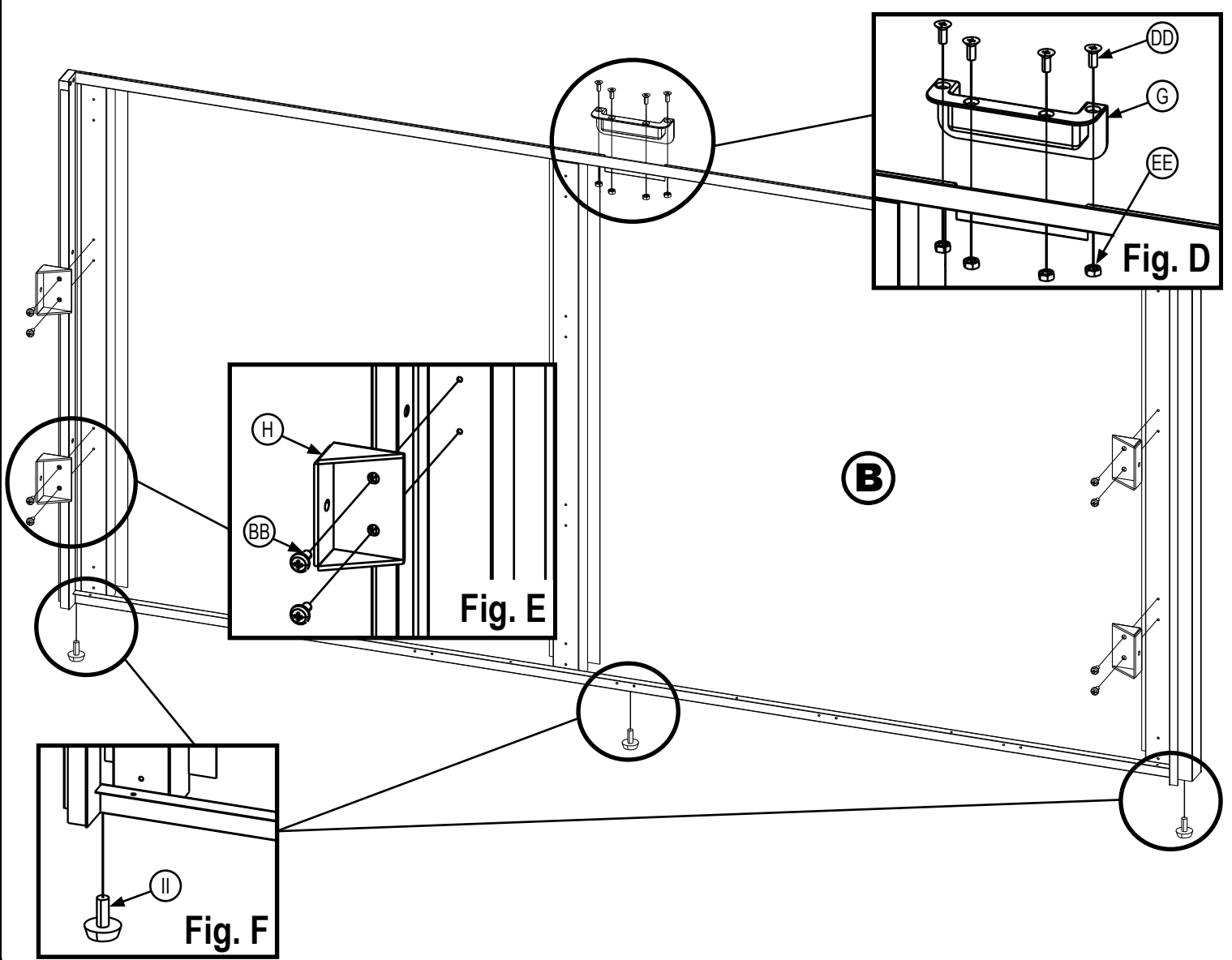

# Step 3

You will need for this page:

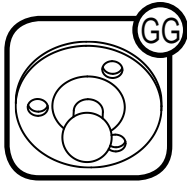

- Lid Panel - A  
(QTY: 1)
- Top Air Spring Pedestal - GG  
(QTY: 2)

**1** Attach Top Air Spring Pedestal to Lid Panel using Screws provided with Top Air Spring Pedestal as shown in Figure G.

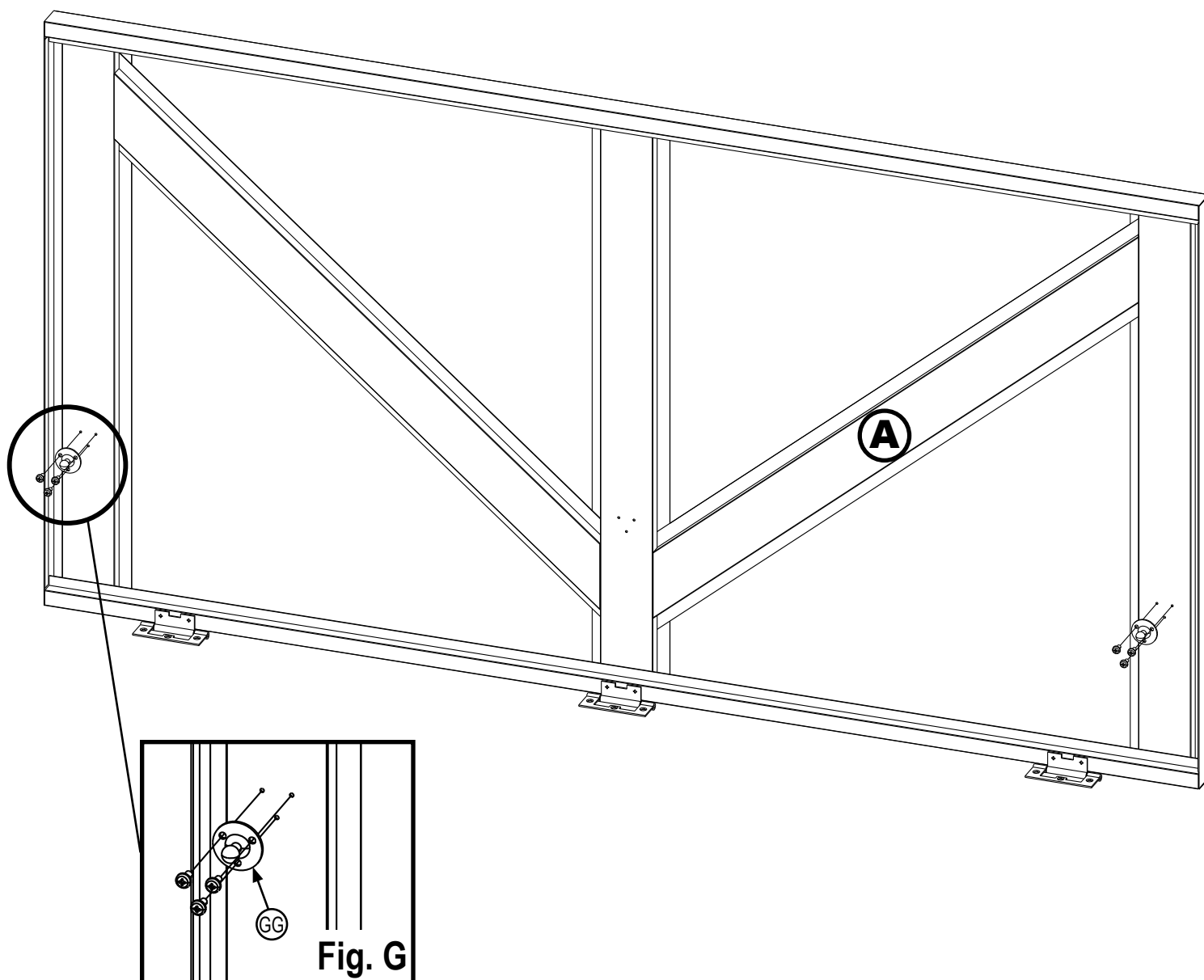



# Step 4

You will need for this page:

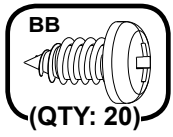

- Back Panel Assembly (Step 1)
- Front Panel Assembly (Step 2)
- Strength Ribs - F  
(QTY: 5)

**1** Assemble **Front Panel Assembly**, **Back Panel Assembly**, and five (5) **Strength Ribs** together using twenty (20) **Hardware BB** as shown in Figure H.

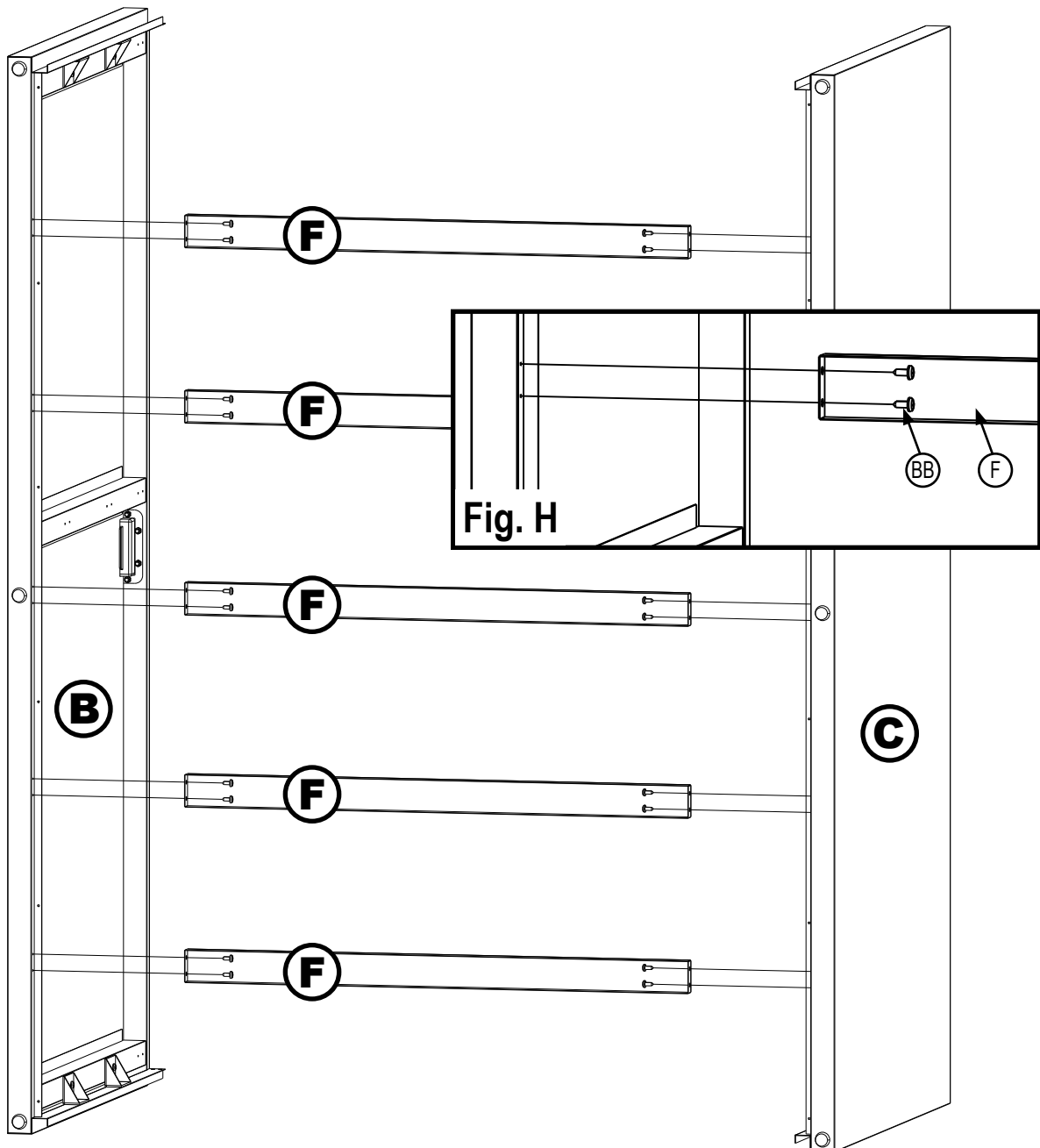

# Step 5

You will need for this page:

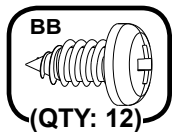

- Bottom Panel - E (QTY: 1)

1 Attach the **Bottom Panel** using twelve (12) **Hardware BB** as shown in Figure I.

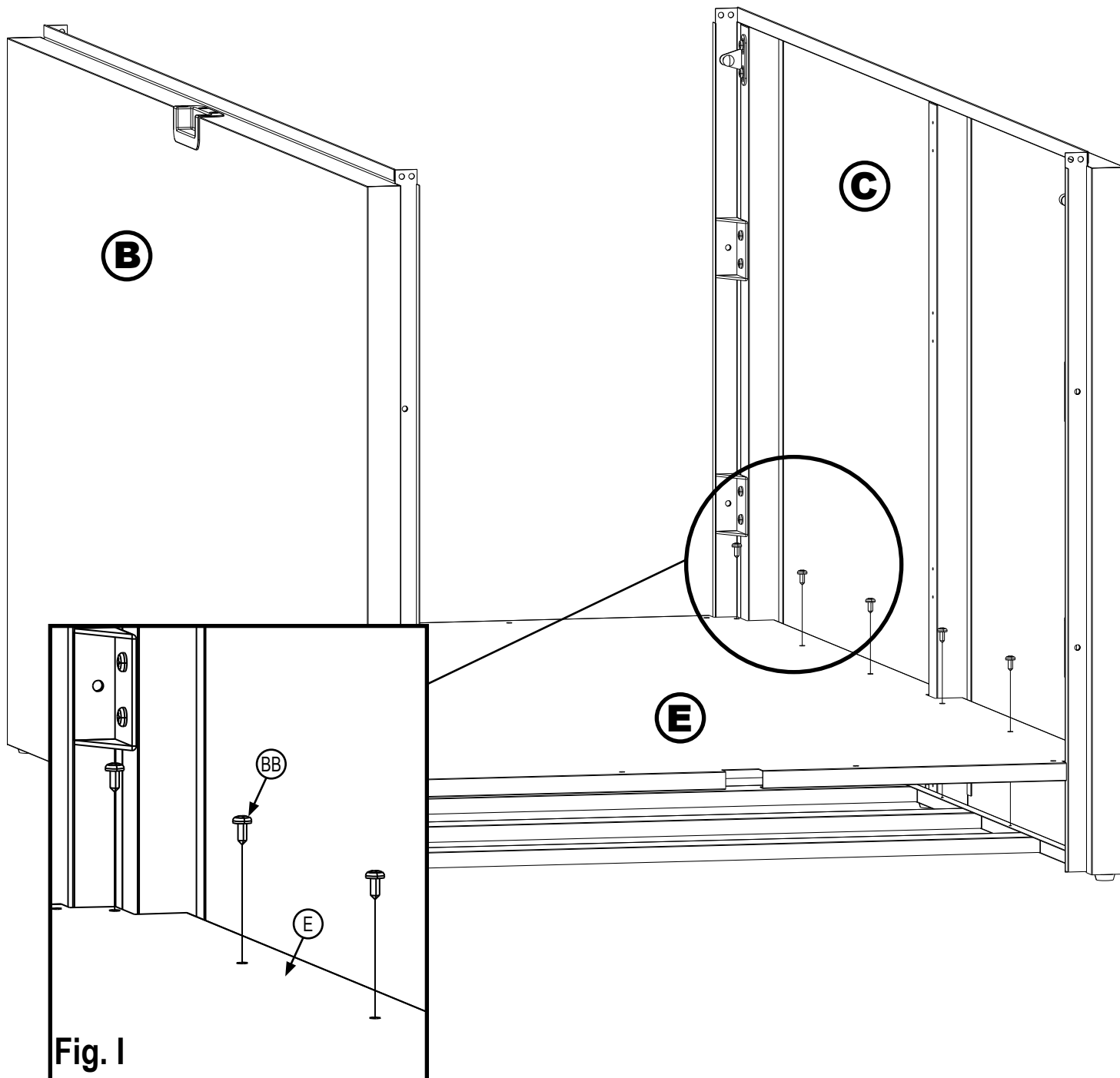

# Step 6

You will need for this page:

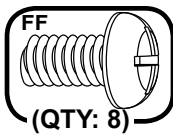
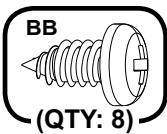
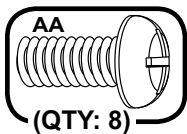

• Left/Right Panel - D  
(QTY: 2)

- ① Attach one (1) **Left/Right Panel** using four (4) **Hardware FF** and four (4) **Hardware EE** as shown in Figure J.
- ② Attach **Left/Right Panel** at **Corner Support** using four (4) **Hardware AA** as shown in Figure K.
- ③ Attach **Left/Right Panels** to **Bottom Panel** using four (4) **Hardware BB** as shown in Figure L. Repeat for other **Left/Right Panel**.

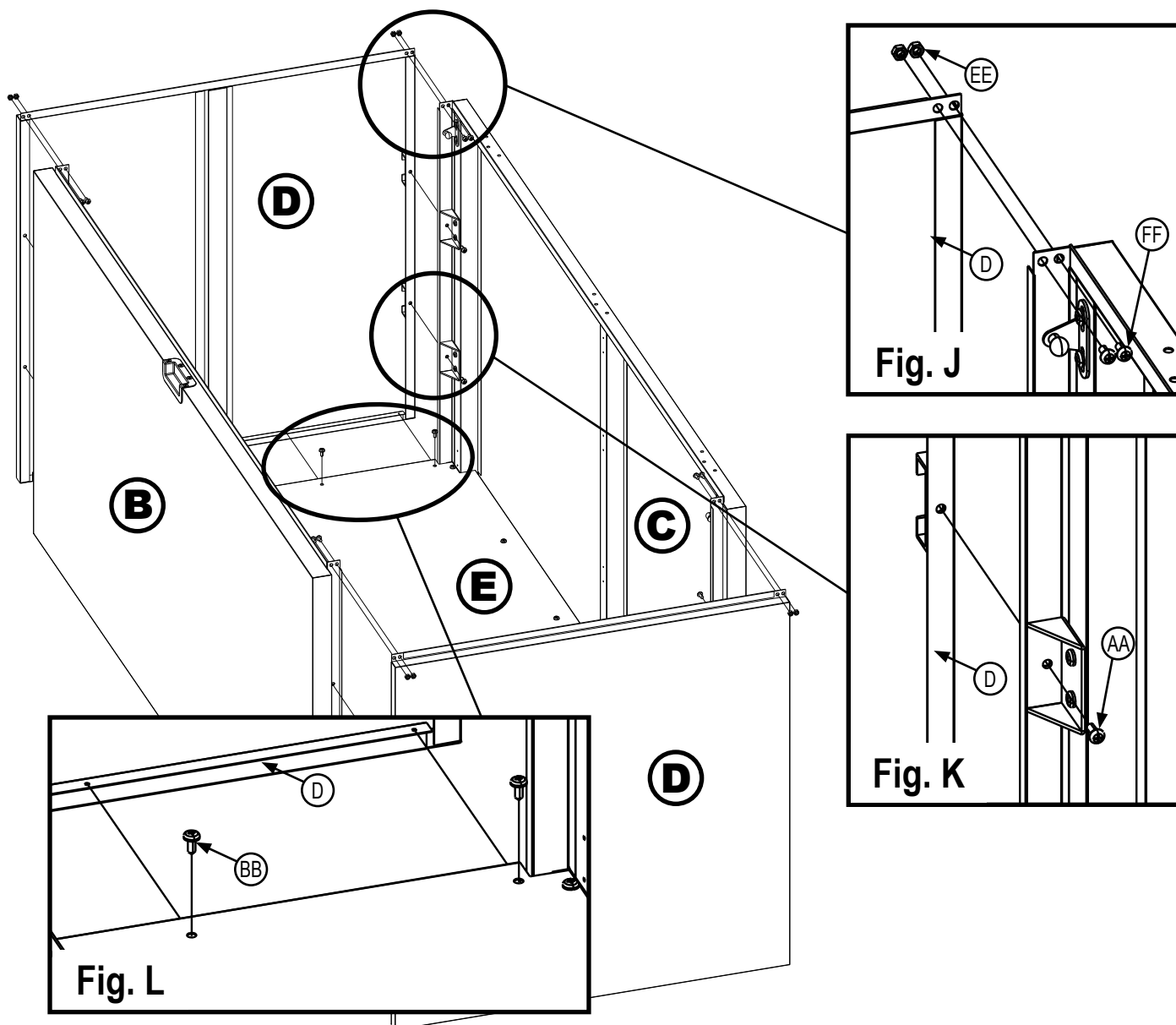

# Step 7

You will need for this page:

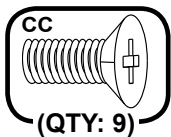

- Lid Panel Assembly (Step 3)
- Air Spring - JJ  
(QTY: 2)

- 1 Connect the **Lid Panel Assembly** to assembled box using nine (9) **Hardware CC** and nine (9) **Hardware EE** as shown in Figure M.
- 2 Insert both ends of **Air Spring** into **Top Air Spring Pedestal** and **Bottom Air Spring Pedestal**.

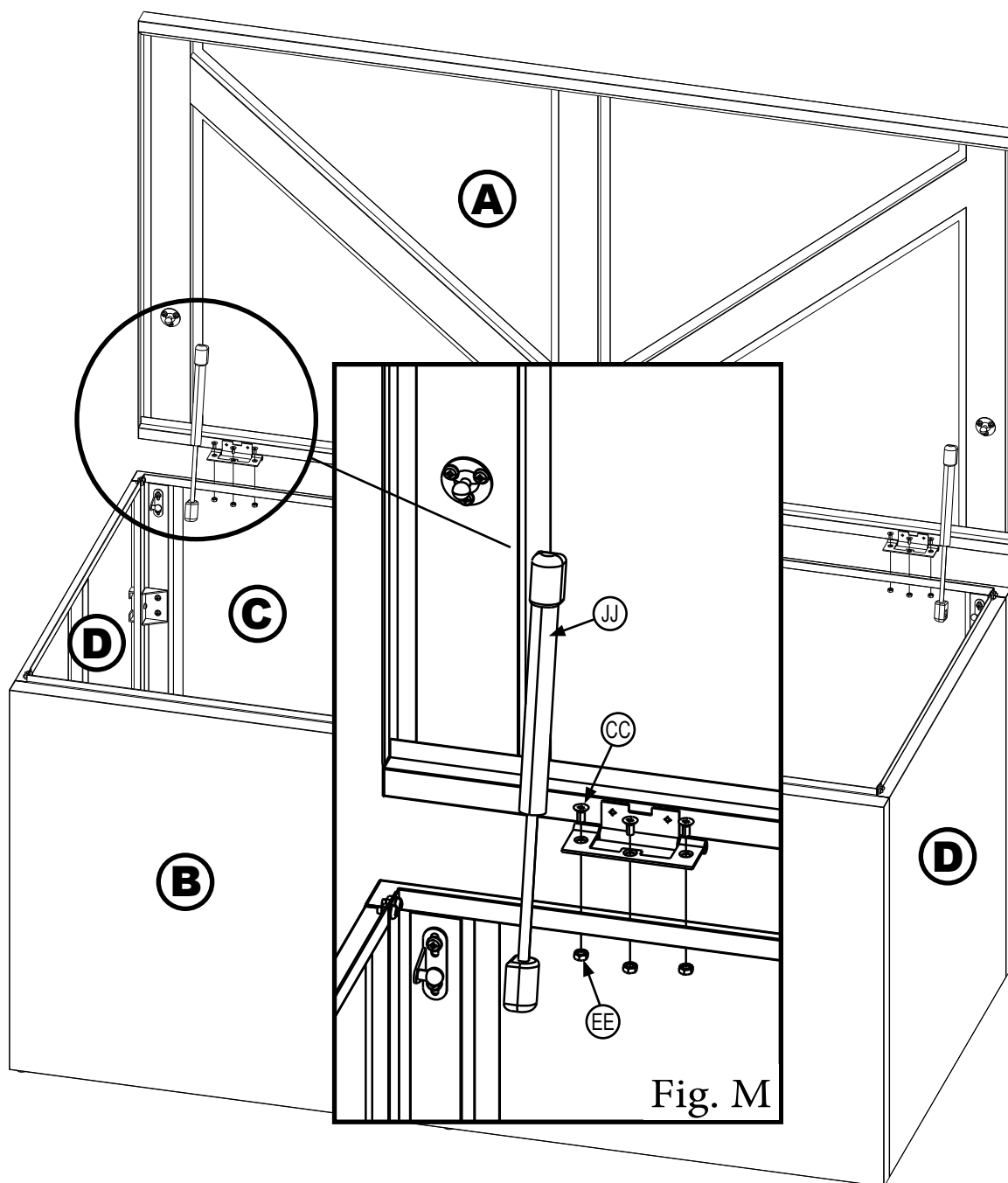

# CARE & MAINTENANCE...

## ***Exterior Care:***

For a long lasting finish clean the exterior surface. We recommend washing with a mild soap solution. **DO NOT** use power washing, bleach, ammonia, or caustic cleaner to clean your storage unit. Using a spray automotive type wax periodically on the exterior is highly recommended if you are in a high humidity or coastal climate region.

Combustibles must be stored in air tight containers designed for combustible storage.

## **NOT RECOMMENDED FOR STORAGE OF CORROSIVE OR FLAMMABLE CHEMICALS OR PRODUCTS**

Rust protection precautions may help to stop rust from developing, or stop it quickly as soon as it appears.

- Do not stand on lid.
- Avoid nicking or scraping the coating surface, inside and out.
- Keep storage unit free of debris and leaves which may accumulate and retain moisture. These can do double damage since they give off acid as they decay.
- Touch up scrapes or nicks and any area of visible rust as soon as possible. Make sure the surface is free of moisture, oils, dirt or grime and then apply an even film of high quality touch-up paint.
- Various paint manufacturers provide products for rust treatment and coverage. If surface rust does appear on your storage unit we recommend treating those areas as soon as possible, following the paint supplier of your choice instructions.
- Exercise caution when moving fully loaded product. This is not intended for transporting heavy objects. This product is recommended for stationary storage.
- Not intended for usage by children. This is not a toy box. To avoid risk of suffocation, do not allow children to play inside container.

## ***Fasteners:***

Regularly check screws, bolts, nuts, etc., and retighten as necessary.

## ***General:***

- Silicone caulking may be used for watertight seals throughout the storage unit.

Please note, Manufacturer cannot be held responsible for any consequences due to storage units that are not installed per these instructions, or for damage due to weather conditions or acts of God.

**Keep these assembly instructions and owner's manual for future reference.**

# ASSEMBLY NOTES

# ASSEMBLY NOTES

