



INSTRUCTIONS FOR:

HYDRAULIC PIPE BENDERS 12 & 16TON

MODEL No's: **PBS99/10.V3, PBS99/14.V3**

Thank you for purchasing a Sealey product. Manufactured to a high standard this product will, if used according to these instructions and properly maintained, give you years of trouble free performance.



IMPORTANT: PLEASE READ THESE INSTRUCTIONS CAREFULLY. NOTE THE SAFE OPERATIONAL REQUIREMENTS, WARNINGS AND CAUTIONS. USE THE PRODUCT CORRECTLY AND WITH CARE FOR THE PURPOSE FOR WHICH IT IS INTENDED. FAILURE TO DO SO MAY CAUSE DAMAGE AND/OR PERSONAL INJURY AND WILL INVALIDATE THE WARRANTY. PLEASE KEEP INSTRUCTIONS SAFE FOR FUTURE USE.

1. SAFETY INSTRUCTIONS

- ✓ Ensure the pipe bender is in sound condition and good working order. Take action for immediate repair or replacement of damaged parts. *Use recommended parts only. The use of improper parts may be dangerous and will invalidate the warranty.*
- ✓ Keep pipe bender and associated parts clean for best and safest performance.
- ✓ Locate the pipe bender in a suitable, well lit working area.
- ✓ Keep working area clean, tidy and free from unrelated materials.
- ✓ Use on level and solid ground, preferably concrete.
- ✓ Ensure all non-essential persons keep a safe distance whilst the pipe bender is in use.
- ✓ Wear appropriate safety apparel, including gloves and eye-shields.
- ▲ **Caution!** Cut pipe edges may be sharp, take care when handling any cut steelwork.
- ✓ Check that bending die is correctly seated on ram and that the roller shafts are fully engaged in the frame and pinned before operating hydraulic unit.
- ✓ Keep hands away from die and rollers when bending pipe.
- ✓ Use a qualified person to lubricate and maintain the hydraulic unit.
- ✓ Confirm that the recommended *hydraulic oil* is used during maintenance.
- * **DO NOT** top up system with brake fluid. Use hydraulic oil only.
- * **DO NOT** operate the pipe bender if damaged.
- * **DO NOT** allow untrained persons to operate the pipe bender.
- * **DO NOT** exceed the rated capacity of the hydraulic unit (see Section 2).
- * **DO NOT** use the pipe bender for purposes other than that for which it is intended.
- * **DO NOT** alter the pressure control valve.
- ✓ When not in use store pipe bender, with the hydraulic ram in the down position, in a dry, childproof area.

When using hydraulic type pipe benders, the bent pipe or tube is prone to deformation on both the inside and outside curvature.

The pipe or tube can be deformed into an oval shape or creased depending on the wall thickness of the material. This is not a fault and largely unavoidable.

Consider packing the pipe or tube with dried sand or similar medium before bending as this may help to alleviate deformation of the pipe or tube. Pack the sand tight and cap both ends.

2. INTRODUCTION

PBS99/10.V3

Floor standing pipe bender with fabricated steel chassis and heavy-duty 12ton hydraulics with integral pump and reservoir. Fitted with externally mounted return springs. Suitable for bending gas and air pipe from Ø15mm(1/2") up to Ø51mm(2"). Supplied with six steel dies to help prevent pipe distortion. Bends up to 180° (3 x 60° bends).

PBS99/14.V3

Floor standing pipe bender with fabricated steel chassis and heavy-duty 16ton hydraulics with integral pump and reservoir. Fitted with externally mounted return springs. Suitable for bending gas and air pipe from Ø15mm up to Ø75mm(3"). Supplied with eight steel dies to help prevent pipe distortion. Bends up to 180° (3 x 60° bends).

3. OPERATION & MAINTENANCE

WARNING! Ensure that you read, understand and apply Section 1 safety instructions before operating the pipe bender.

- 3.1** Before first use, purge the hydraulic circuit, in order to eliminate any air from the system, as follows:
- a) Fit jack handle over release valve (fig.1.1) and turn anti-clockwise to open valve.
 - b) Insert jack handle into the handle sleeve (2) and pump several times to ensure full internal lubrication and to bleed air from the system.
 - c) When complete place the handle back over the release valve (1) and turn clockwise to close.

- 3.2. With the hydraulic unit release valve open and the ram fully retracted, fit the appropriate sized die to the ram.
- 3.3. Move pipe rollers and shafts to appropriate holes in frame and ensure that shafts are properly fitted and secured using hitch pins.
- 3.4. Introduce the pipe between the die and rollers, positioning it so that the centre of the required bend in the pipe is over the centre of the die.

Note! Consider packing the pipe or tube with dried sand or similar medium before bending as this may help to alleviate deformation of the pipe or tube. Pack the sand tight and cap the ends.

- 3.5. Close release valve and pump handle until the required degree of bend is achieved.
- 3.6. Using the end of the handle, open the release valve and ram will retract under spring tension.
- 3.7. Annually, replace hydraulic oil using Sealey Hydraulic Jack Oil. With ram fully down, drain and refill to bottom of filler plug hole.

Fig.1

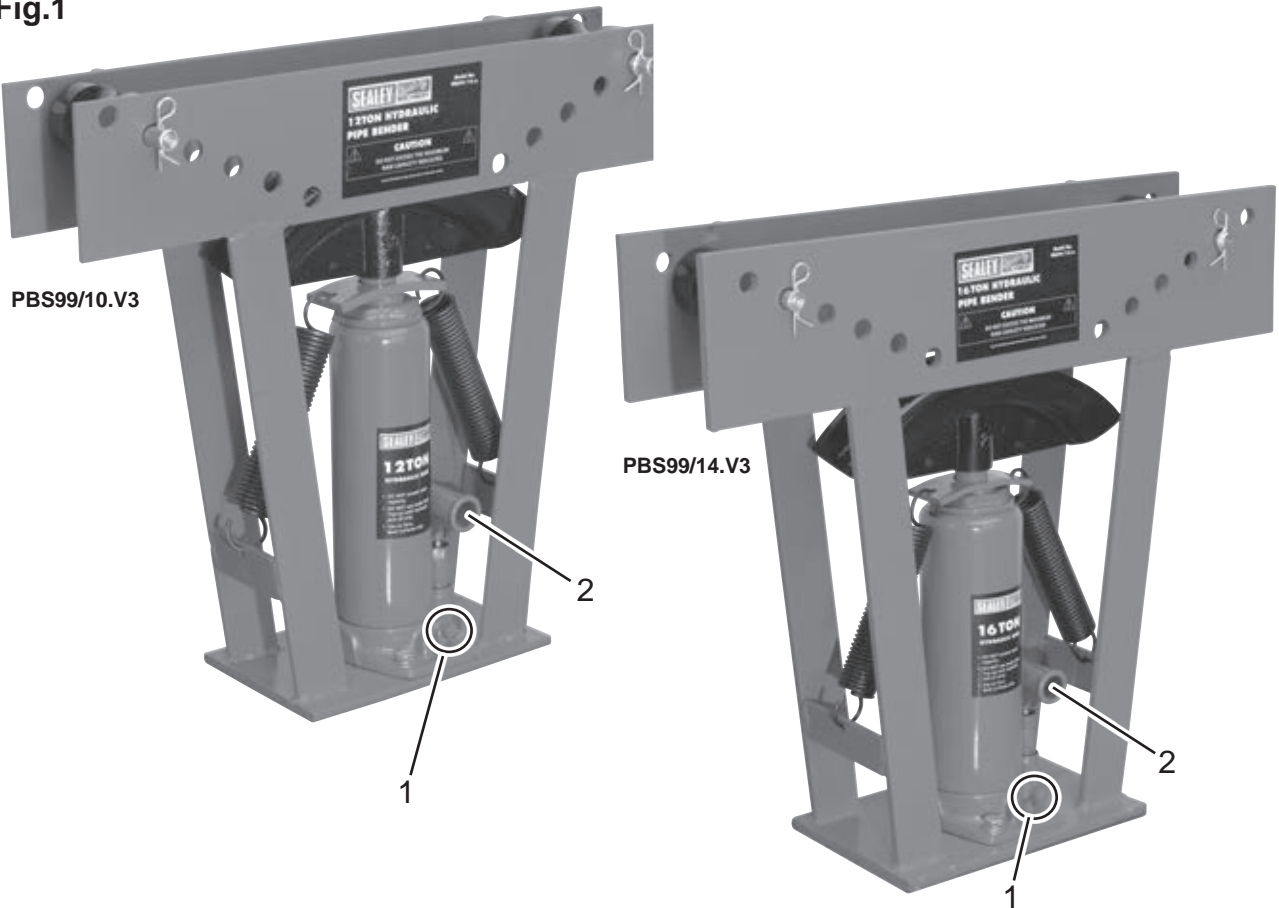

NOTE: It is our policy to continually improve products and as such we reserve the right to alter data, specifications and component parts without prior notice.
IMPORTANT: No liability is accepted for incorrect use of product.
WARRANTY: Guarantee is 12 months from purchase date, proof of which will be required for any claim.



Sole UK Distributor
 Sealey Group,
 Bury St. Edmunds, Suffolk.

01284 757500
 01284 703534

www.sealey.co.uk
sales@sealey.co.uk