

MACHINE BITS

MACHINE BITS FOR HINGE SINKING

• These machine bits are typically used by kitchen furniture manufacturers for recessing circular hinges.

• Group 104

This type with scribers are used on natural timber, particle boards and veneered MDF.

• Group 421

This type without scribers are for laminate covered boards.

• Group T421

This hinge sinker is best suited for thinner laminate covered boards.

• Group T420 TCT

This economy range is supplied without scribers and are used for recessing holes in melamine covered chipboard.

• Ref. T420 WS

This economy tool is supplied with scribers and centre point and is used for recessing holes in softwoods.

▲ Use sizes above 25.0mm at recommended speed range 1,000 - 3,000 RPM maximum to avoid burning.

▲ Use with pillar drills only.

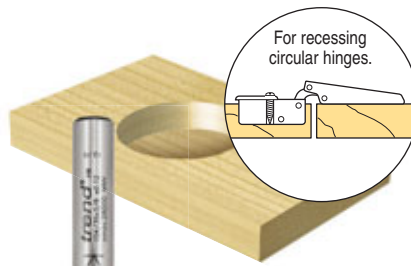

For recessing circular hinges.

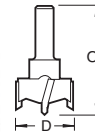

Ref. 104 Group
Use for natural wood veneers or veneered particle boards.

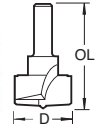
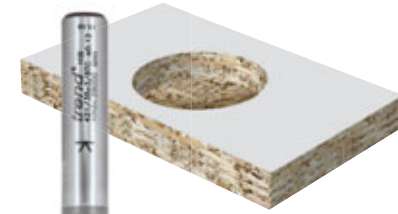

Ref. 421 Group
Use for laminate covered boards.

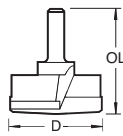

Ref. T421/35
Use for general purpose work.

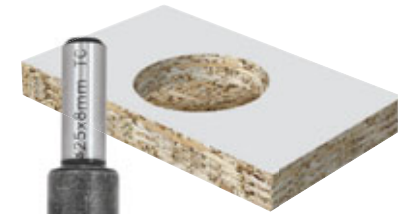

Ref. T420 Group TCT
Use economy range for melamine covered chipboard.

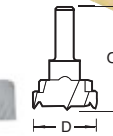
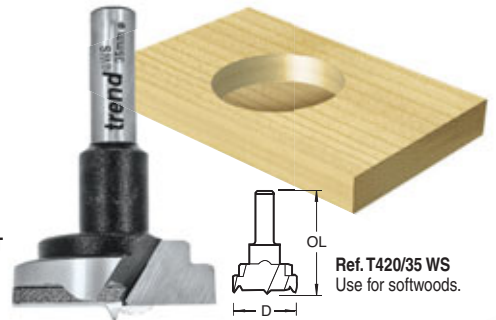

Ref. T420/35 WS
Use for softwoods.

Head Design	D mm	OL mm	Product Ref.	TCT	
				1/4"	3/8"
Two wings, two scribers & centre point	25.0	65.0	104/25	-	£48.04
	35.0	65.0	104/35	£50.00	£48.71

Two wings, no scribers & centre point	20.0	60.0	421/20	-	£34.02 +
	26.0	65.0	421/26	-	£34.62 +
	35.0	65.0	421/35	£41.69	£41.69

Two wings & no centre point	35.0	45.0	T421/35	£24.34	-
-----------------------------	------	------	---------	--------	---

Head Design	D mm	OL mm	Product Ref.	CRAFTPRO	
				TCT	
Two wings & centre point	35.0	57.0	T420/35	8mm	
				£11.25	

Head Design	D mm	OL mm	Product Ref.	CRAFTPRO	
				WS	
Two wings & centre point	35.0	54.0	T420/35	8mm	
				£7.26	

TAPERED PLUG MAKER

- A tapered plug ensures an exceptionally tight fit is achieved.
- Tapered plug cutters with Tungsten Carbide Tips will produce many hundreds of plugs before re-sharpening is required.

▲ For use in drilling machines at a recommended speed of 2,000 RPM (max. 3,000 RPM). Material must be well clamped.

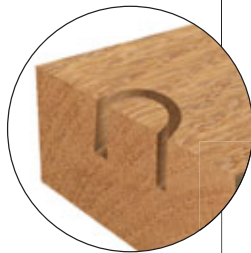

Ref. 24/1

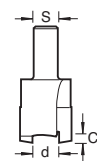
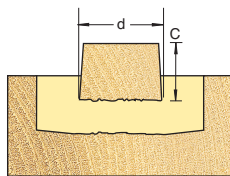

d Suitable for Hole Size inch	d Suitable for Hole Size mm	C Plug Depth mm	S Shank Dia. inch	Product Ref.	TCT
1/2	12.7	15.0	1/2	24/1	£78.60

MACHINE BITS LIP & SPUR

- These machine bits have two wings, two scribers and a centre point.
- Tungsten Carbide Tipped for extensive drilling of particle boards and plastics of soft to medium density.
- The scribes give a very clean entrance hole.



Ref. 1004/34



Max. Speed	D mm	OL mm	S mm	Product Ref.	TCT	
10,000 RPM	10.0	90.0	10.0	1004/10 +	£21.07	
	15.0	90.0	10.0	1004/15 +	£31.86	
	18.0	90.0	10.0	1004/18 +	£33.00	
	19.0	90.0	10.0	1004/19 +	£33.00	
	20.0	90.0	10.0	1004/20	£42.49	
6,000 RPM	25.0	90.0	10.0	1004/25	£43.15	
	30.0	90.0	10.0	1004/30 +	£35.66	
	31.0	90.0	10.0	1004/31 +	£35.66	
3,000 RPM	34.0	90.0	10.0	1004/34 +	£36.18	
	35.0	90.0	10.0	1004/35	£46.58	
	38.0	90.0	10.0	1004/38	£52.80	
	40.0	90.0	10.0	1004/40	£52.80	
	45.0	90.0	10.0	1004/45 +	£58.28	
	50.0	90.0	10.0	1004/50 +	£63.73	

▲ Not for use on hard dense materials, such as laminate covered board, phenolic Tufnol®, Wareite® & GRP. For such materials, choose from Group 421 tools which have no scribes. For use in drilling machines only.