

# **IN** Profile

**6** ISSUE  
AUTUMN 09

**The magazine for all Trend Users**

**The New  
T5 v2 Router**  
Improved features

**Autumn  
Promotions**  
Vouchers included

**Router  
Scrappage  
Scheme**  
Trade in your old router

**Time Saving  
Solutions**  
For the Tradesman

**Tips & Projects**  
From our Knowledge Base

**New  
Products**  
Cutters, T60 Glue Gun,  
Snappy Tooling & more

**trend**  
routing technology

**trend**<sup>®</sup>  
routing technology



# CUTTING EDGE

Leading the way in Technology and Innovation

With over 3000 Quality Router Cutters available, we have a range to suit everyone.



**PROFESSIONAL RANGE**  
The most popular range of Tungsten Carbide Tipped router cutters in the UK. Includes a range of **DYNAMIC** Carbide extended life cutters.

**TRADE RANGE**  
Concise range of extra long Tungsten Carbide Tipped cutters with PTFE coating, designed and packaged for the Tradesman.

**CRAFTPRO RANGE**  
Comprehensive range of Tungsten Carbide Tipped cutters specifically designed for the needs of the woodworker.

For more information visit [www.trend-uk.com](http://www.trend-uk.com)

**trend**  
routing technology

## 2008/9 CATALOGUE

Phone 0800 487363 for your free 2008/9 Routing Catalogue and details of your nearest stockist.

web: [www.trend-uk.com](http://www.trend-uk.com) | email: [enquiry@trendm.co.uk](mailto:enquiry@trendm.co.uk)



## 12 Time Saving Solutions for the Tradesmen

We outline 12 solutions for saving time and money on-site and around the home.

## 15 New Cavity Access System

Gain access to underfloor pipes and cables in seconds with this new system.

## 16 New T60 Cordless Glue Gun

High strength gluing in seconds with the new T60 Glue Gun.

## 17 Router & Cutter Deals

Trade in your old router and save up to £30 on your new Trend router. Free cutters included.

## 18 Hints, Tips & Routing Jigs

Routing hints and tips together with a selection of user-made routing jigs.

## 20 Furniture Focus 6

Joining and moulding hardwood edgings when constructing a carcass.

# In this issue

## 4 New Cutters Setting the Trend

A round up of the latest router cutters developed by Trend this year.

## 6 New T5EK v2 Review

Alan Holtham takes the new improved T5 through its paces.



## 10 On-line Routing Projects

We show you how to make your very own custom made workbench just for routing.

Welcome to the latest edition of INPROFILE, our unique magazine for the woodworkers of the world. Over the years, Trend has developed products for the tradesman, the furniture and cabinetmakers, light industry and the keen woodworking hobbyist. This edition of INPROFILE brings many interesting articles for everyone working with wood. From the wide range of jigs to suit the needs of the trade to the versatile CNC machines that suit light industry, the magazine has something to suit all woodworking interests. Throughout the magazine, you will notice references to our completely redesigned website. We recommend you give the website a visit and try out all the new features and functionality. Finally, look out for our new window tooling system, a quick and low cost solution to making wooden windows. We hope you enjoy this issue and we look forward to any suggestions or comments you may have.



Stephen Phillips  
Editor



**Editor**  
Stephen Phillips  
**Technical advisor**  
Neil McMillan  
**Design & layout**  
Annette Kelly  
**Graphics**  
Tom Evans

## 22 Diamond Sharpening Techniques

Looking after tools with regular honing to keep them in tip top shape.

## 24 Snappy Quick Release System

We highlight the many and varied applications of Snappy products.

## 26 Windows By Numbers

Make timber windows quickly and accurately using our revolutionary Modular Window System.

## 28 PRT Router Table

A quick overview of the many features of our Professional Router Table.

## 30 Technology Meets Tradition

Making electric guitars using the Trend CNC Smart router.



See our 20 Autumn Promotion vouchers in the centrefold.



**New T60 Glue Gun**

See page 16

**Trend Machinery & Cutting Tools Ltd**  
FREEPOST WDB118  
Odham Trading Estate, St Albans Road, Watford WD24 7TR

All Trend products are available through a network of retailers. Please call our freephone number for your nearest stockist or visit our website.

**Freephone:** 0800 4 TREN (0800 487363)  
[enquiry@trendm.co.uk](mailto:enquiry@trendm.co.uk)  
[www.trend-uk.com](http://www.trend-uk.com)

2009© Published by Trend Machinery and Cutting Tools Ltd. All rights reserved. No part of this publication may be reproduced, stored or transmitted in any form without prior permission. Our policy of continuous improvements means that specifications may change without notice. Trend Machinery and Cutting Tools Ltd. cannot be held liable for any material rendered unusable, or for any form of consequential loss. Prices are valid at time of print.



The new T5EK v2 router trimming with cutter Ref. 46/902.

**UNIQUE SMALL DIAMETER**

### New Template Profilers

These two flute shank mounted bearing template profiler router cutters (sizes 9.5mm x 13mm and 12.7mm x 12.7mm) are ideal for profiling and trimming applications on wood and man-made boards. Also for jig making and shield/display stand manufacture. Can be used in a router table or hand router.

46/902X1/4TC (9.5mmØ) £20.00  
46/913X1/4TC (12.7mmØ) £24.50

# New Cutters

## Setting the TREND

A round up of the latest router cutters we have developed over the last year.

**LONG 70MM CUT**

### New Long Trade Straight Router Cutters

Two new Trade cutters, PTFE non-stick coated with two flute Tungsten Carbide tips for timbers and man-made boards including lightweight honeycomb worktops. The Tungsten Carbide centre tip is designed for deep plunge routing. Sizes 14mm dia. x 70mm cut length and 19.1mm (3/4") dia. x 51mm (2") cut length.

TR44DX1/2TC (14mmØ) £35.00  
TR45DX1/2TC (19.1mmØ) £28.00

### New 1/2" Straight Worktop Router Cutter

A new Tungsten Carbide tipped two flute cutter with 50mm cut length and plunge cut facility. It has increased clearance for resinous materials and is also ideal for kitchen worktops.

3/83DCX1/2TC £29.00

**SUPER FINE FINISH**

### New Solid Carbide Guided Spiral Trimmers

Two new 1/4" shank Carbide guided spiral trimmers with nose mounted bearing guides 6.35mm in dia. and 25.4mm cut length. Designed for hard plastics, timber and man-made boards. Down-cut version is ideal for single-sided veneered material.

S64/2X1/4STC £50.00 (up-cut)  
S64/2LHX1/4STC £50.00 (down-cut)

### New Extra Long 1/2" Straight Router Cutter

With an extra long cut length of 75mm, this unique Tungsten Carbide Tipped cutter is designed to cut through lightweight honeycomb worktops. Use with a professional router with 80mm deep plunge to ensure safe cutter retraction into base.

3/86X1/2TC £37.50

**LONG 75MM CUT**

'Honeycomb Worktop' is a new style of kitchen worktop that is lightweight and has a honeycomb structure for strength. A 60mm thick worktop is shown.

### New 95° Stair Housing Cutter

This left hand counter rotation cutter has been added to match the standard RT/323X1/2TC. Designed for use with stair housing machines the size is 22mm diameter x 28mm cut length.

RT/323X1/2LTC £106.50

### New Replaceable Tip Worktop Cutter

With a reversible Solid Carbide blade and single flute, it is suitable for plunge cutting with Trend Combi Worktop Jigs. With a 1/2" diameter and 29.5mm cut length it has a special relieved neck for a depth of cut of 50mm.

TR43X1/2TC £52.00

**THREE FLUTE**

### New Guided 45° 3 Flute Chamfer Router Cutter

Three flute guided 45° chamfer router cutter with a 11mm cut length and 34mm in diameter. For use on wood and any man-made boards. Superb for giving an extra fine professional finish where detail is paramount.

41/5X1/4TC £39.00

### New HSS Four Flute Spiral Acrylic Cutter

High speed steel four fluted up-cut spiral cutter with a 12.7mm (1/2") shank diameter and 45mm cut length. Excellent for trimming, rebating and surfacing acrylic. Can also be used for ramp plunge cutting on CNC machines.

56/3X1/2HSS £35.00

**FOUR FLUTE**



The new T5EK v2 with its distinctive red spindle lock button.

# The New T5EK v2 Review

**AVAILABLE NOVEMBER**  
Please check website



**Alan Holtham gives the New T5 v2 a thorough work-out, to see if the best really has just got better.**

I have been using a Trend T5 router for several years; in fact I have two of them in more or less constant use in the workshop. Based on the iconic Elu MOF 96, to me the T5 embodies everything you need in a router, but in a simple, uncomplicated form. Normally I would recommend that with any power tool you should always buy the biggest, but in the case of a router the situation is somewhat different and for the majority of work a smaller, lighter model is far more user friendly.

The T5 has always ticked all the boxes for me, so with some considerable experience of the model I was interested to see if there were any significant improvements on this latest version. I tested the standard version which is fitted with my preferred sliding on/off switch. There is also a T5 Mk 2 version with

exactly the same features but with the 'dead man' type of switch, although you can buy an optional lock for this if you want to mount the Mk 2 under a table. The T5 is supplied in 240 or 115 volt options, and comes either as the basic machine only, or in kit form which includes a carrying case and several useful accessories.



**New soft grip handles, for safe adjusting of the plunge lock.**

The most obvious improvement has to be the new soft grip handles. On the older versions there is a join on the two halves of the hard plastic handles, but these new softer ones are a real upgrade to the ergonomics.

The motor power has also been updated from 850 to 1010 watts. This may not seem a lot, but in reality, coupled to the fact that the T5 will take an 8mm collet, it means that the machine is capable of using some relatively big cutters up to a maximum diameter of 40mm. Previously this size of cutter had to be used with bigger and much less user-friendly half inch routers. I am pleased to see that 8mm shank cutters, previously the preserve of our European cousins, are now beginning to appear in a wider range of profiles in the UK. The extra rigidity of 8mm over the equivalent 1/4" shank version is quite considerable, particularly with the long narrow cutters. This combination of



**Adjusting the depth flag for depth of cut.**

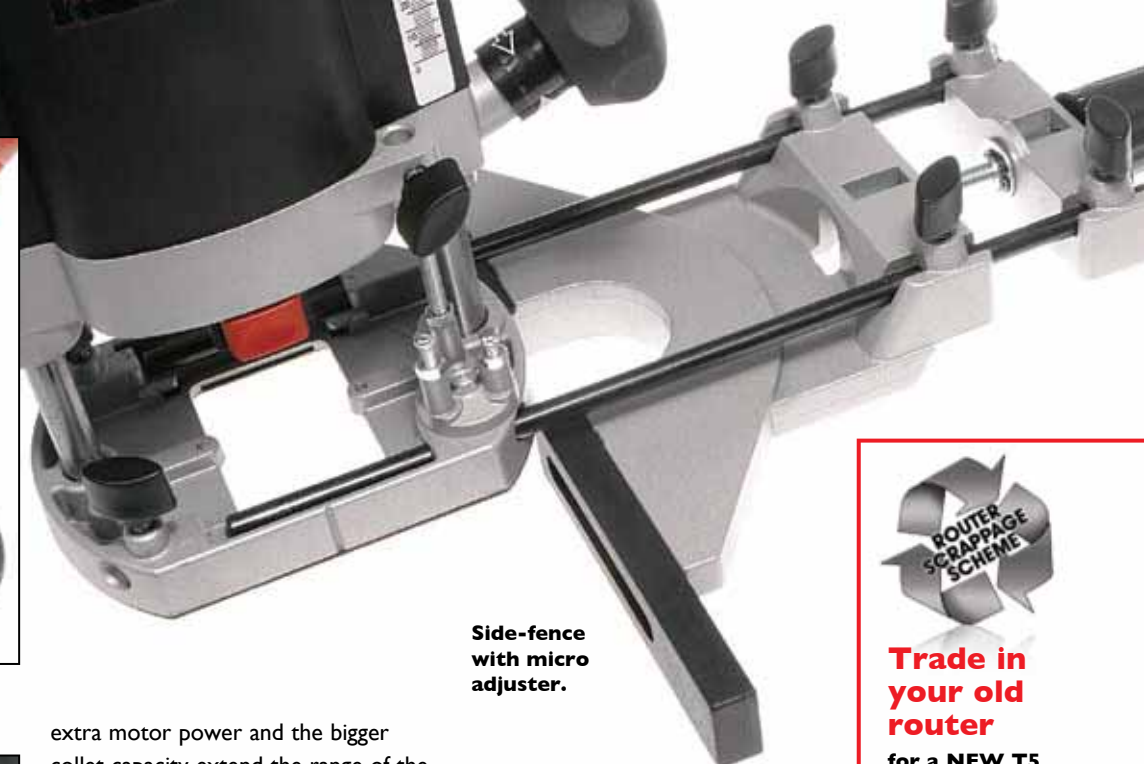

**Side-fence with micro adjuster.**



**Trade in your old router for a NEW T5 and receive 3 FREE cutters. See page 17.**

extra motor power and the bigger collet capacity extend the range of the new T5 considerably. In the kit form I tested both sizes of collet which are provided as standard.

There have also been some minor changes to the router base with extra sight-lines being engraved on the sides and back. As you would expect the base has the standard TBC configuration, which means that the huge range of Trend accessories and jigs can be fitted without additional sub-bases. For me, the two flats on the base make it much easier to work against the straight edge. I have never been very keen on round base routers for this job although theoretically they should be just as good. For template work a 20mm guide bush is provided in the kit, with other sizes available as optional extras.

The spindle lock has been repositioned and redesigned with a more comfortable knob making it very easy to change cutters using a single 17mm spanner.

For dust extraction, a new clear plastic hood now clips in on both sides of the base and is probably as good as you get on a router. It is also lower in profile so you still maintain maximum plunge when using it. The snag is that whatever you fit for extraction it always seems to make it awkward to change cutters, and anyway the dust flies off in different directions depending on the type of cut. No one has yet cracked the problem of totally efficient extraction on the router and probably they never will, but the option to route the hose away from

either the front or the back of the tool is a real advantage. And the amount of dust generated is considerably reduced when it's hooked up to a decent collector.

The side-fence has also been modified, mostly with a view to improving the dust collection ability. The integral fine adjuster allows you to move the fence backwards and forwards in 0.1mm increments. My only criticism of this fence is that the mounting bars are rather too short, making it difficult to reach in very far from the edge of a board. Another 75mm in length would make all the difference. However you can buy extra long 500mm bars if this is a real problem to you. The depth stop is still a simple rod operating on the three position turret. I know this is often criticized, but in my opinion its simplicity is a real advantage as any type of depth stop will need zeroing for the amount of protrusion of the cutter and the more complicated the depth stop the trickier this operation becomes. Less is definitely more in this situation.

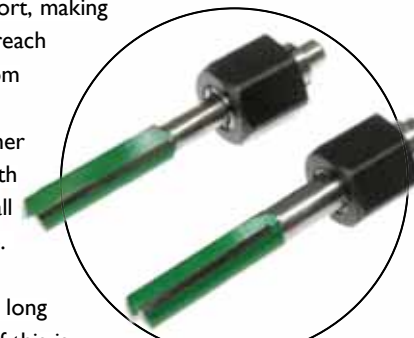

**8mm shanks provide a far larger gripping area.**



**Adjusting the fine height adjuster.**



**New style on/off switch.**



**Using the spindle lock to tighten the collet nut.**



**Adjusting the fence using the microfence adjuster.**



**Base plate showing holes for guide bushes and router tables.**



If depth-of-cut adjustment is critical as with some jigs like the dovetailer, the T5 Kit includes a fine height adjuster which fits onto the long screw of the depth turret. This allows precise control of cut depth and I have one permanently fitted to one of my old T5s.

In use it is hard to fault the new T5; it is still as easy to handle as the original MOF 96, despite the near doubling of power, but still only weighing 3.0kg. Everything is firm and rigid, there is none of that rocking about on the plunge columns that you often get with the cheaper smaller routers. The

**Fitting the new low profile dust spout.**



50mm plunge action is smooth and accurate and quickly locks with the now wonderfully comfortable side handles! The benefits of all the extra power soon become clear with the bigger cutters and you can now make a reduced number of passes, the full wave electronics maintaining a constant speed even under load. Where you

**Fitting the guide bush.**



are removing a lot of material in one pass it becomes essential to use the extraction hood, as without it the dust is thrown everywhere making for a very uncomfortable and unhealthy working environment.



**Using the beam trammel bar to make circles and arcs.**

One final accessory included in the kit is a trammel point that fits onto one of the side-fence bars for cutting circles. This is not something you use very often but is surprisingly effective when you do need it, although some means of locking it onto the fence rod independently of the wing nut clamp would make it easier to use. **TP**

### Conclusion

The original T5 specification was hard to improve, but the additional features of the new model lift it to the top of the class for me. The cosmetic tweaks are all very worthy, particularly to the handles, but the real plus is the improved power output allowing you to access a far greater range of bigger cutters on 8mm shanks without the expense of having to move up to a bigger router. But please could we have some longer fence bars as standard!

**Micro adjustment side-fence.**



**Edge profiling with a bearing guided ogee cutter Ref. 46/30X1/4TC.**



**...and with a bearing guided cove cutter Ref. 46/264X1/4TC.**

## Free Routing Packs

### For schools and colleges

We have 100 information packs to give away to colleges and schools who use routers in their carpentry department. This includes our Complete Routing book and various Trend DVDs on routing. Please use the form enclosed to request this. See centrefold.



### Routing Courses available throughout the UK

Trend continue to sponsor a number of course centres running one or two day routing courses, both basic and advanced. Full instruction is provided on a wide range of Trend products, including hands free routing, safety and maintenance. Each course delegate will also receive a free information pack which includes the Complete Routing book and various Trend DVDs. (Offer open until April 2010).



## NEXT STEP

### Free Routing Packs

Available to schools, colleges and attendees of Trend sponsored routing courses.



### New On-line Video Logo

Look out for this new logo on our packaging, in store displays and on product information to indicate that a video clip is available on our website.



### Power Search

Our website now features a more sophisticated search engine facility. By entering a key word, product reference or phrase, the entire contents of our website can be searched. This includes our entire Knowledge Base and Download library.



## New Videos Now Available On-line

In October we will launch a significant improvement to our video library where you can download or stream Trend product videos from our website. There will be numerous video clips featuring products from across our range. Each video clip will show the features and benefits of each product. Where available the video can also be accessed from within each product page on our website. Look out for more videos in the future.







# On-line Routing Projects



**Alan Holtham shows you how to make a custom made workbench for routing.**

**P**rolonged routing sessions have been taking a serious toll on my ageing back. The problem is that a conventional woodworking bench is at the wrong height for most routing work, as you usually need to get down lower to check the action at the cutting edge. This obviously necessitates a lot of bending with the router extended at arms length, not the ideal situation from an ergonomic point of view. There is also the difficulty of holding the work

**Router bench shown in use. Note the improved stance and visibility at this high level.**

**Narrow work surface for versatile clamping.**

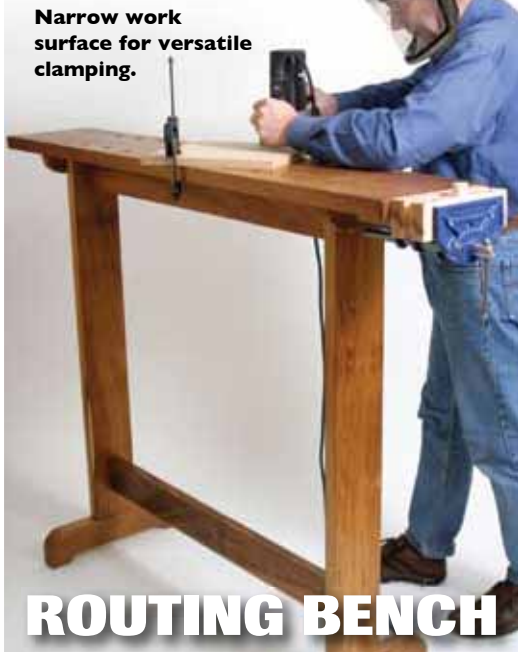

## ROUTING BENCH

securely on a conventional bench, which often has a deep fronted apron and is also very wide, making it difficult to get clamps to hold in the right place. So you always seem to end up clamping and re-clamping the work several times just to make a single cut. I resolved to make a dedicated routing bench, incorporating a range of features designed specifically for use with the router. For a start it needed to be very much taller so that I could always be working at elbow height. Secondly, it needed to be long and narrow with plenty of overhang on the top to allow easy clamping anywhere along the surface. This was further enhanced by the addition of a tail vice and rows of holes that would take standard straight or adjustable dogs, or even a hold down. Any timber will do for the construction, but a dense hardwood will obviously be sturdier than softwood, so I settled on using up some Iroko boards left over from a garden bench making project. You don't need a lot of material and I made the majority of it out of one inch thick board, with just a small amount of two inch for the feet. **LP**



The top is joined up from two pieces to increase the stability. Even if you have a single piece that is wide enough, it is worth splitting it down into two or three pieces and re-jointing it to minimize the risk of it warping later on.

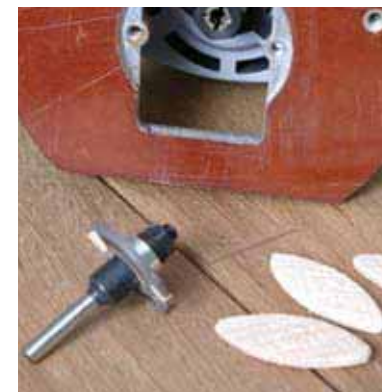

To join the pieces a simple butt joint will suffice, but reinforce it with four or five biscuits using a bearing guided biscuit cutter.



Provided you work from the face-side on each board you do not have to be too fussy about positioning the cutter dead on centre.



I also find it helpful to elongate the slot slightly to give a bit of play at the assembly stage.



Glue up the top using the sash cramps to hold the boards together rather than to close up any gaps. Excessive pressure also runs the risk of distorting the top, so take your time in the first place to produce decent fitting joints.



Set the top aside to dry and start work jointing the uprights into the feet.



These are mortised and tenoned together for maximum strength, the mortise being marked out to be slightly less than the width of the tenon. It is cut out using a long reach 1/2 inch diameter two flute bit.



For an accurately centred mortise use the side-fence to guide the cutter, and then turn the work round running the side-fence down the opposite side. Alternatively you can use the new Trend Self Centering Mortise Base. See page 21.

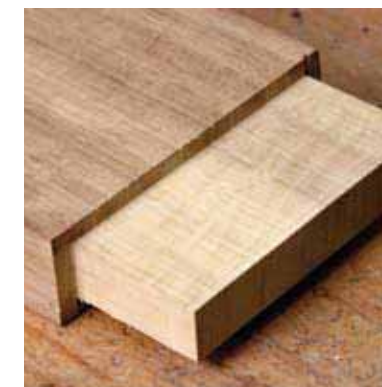

With the mortise cut you can now size the Tenon to suit, a much better option than doing it the other way round. There are numerous ways of cutting tenons, but for large wide ones like this I use the router, again guided by the side-fence.

## NEXT STEP

More >

Go on-line to continue this Routing Bench project and many more.



[www.trend-uk.com/bench](http://www.trend-uk.com/bench)

## Other projects on the Trend website

We have 35 more projects for the router on our website in a clear step by step format.



Bathroom Cupboard



Bathroom Storage Rack



Chopping Box



Coffee Table



Computer Table



Hall Table



MDF Bookcase with Drawers



MDF Table



Radiator Cover



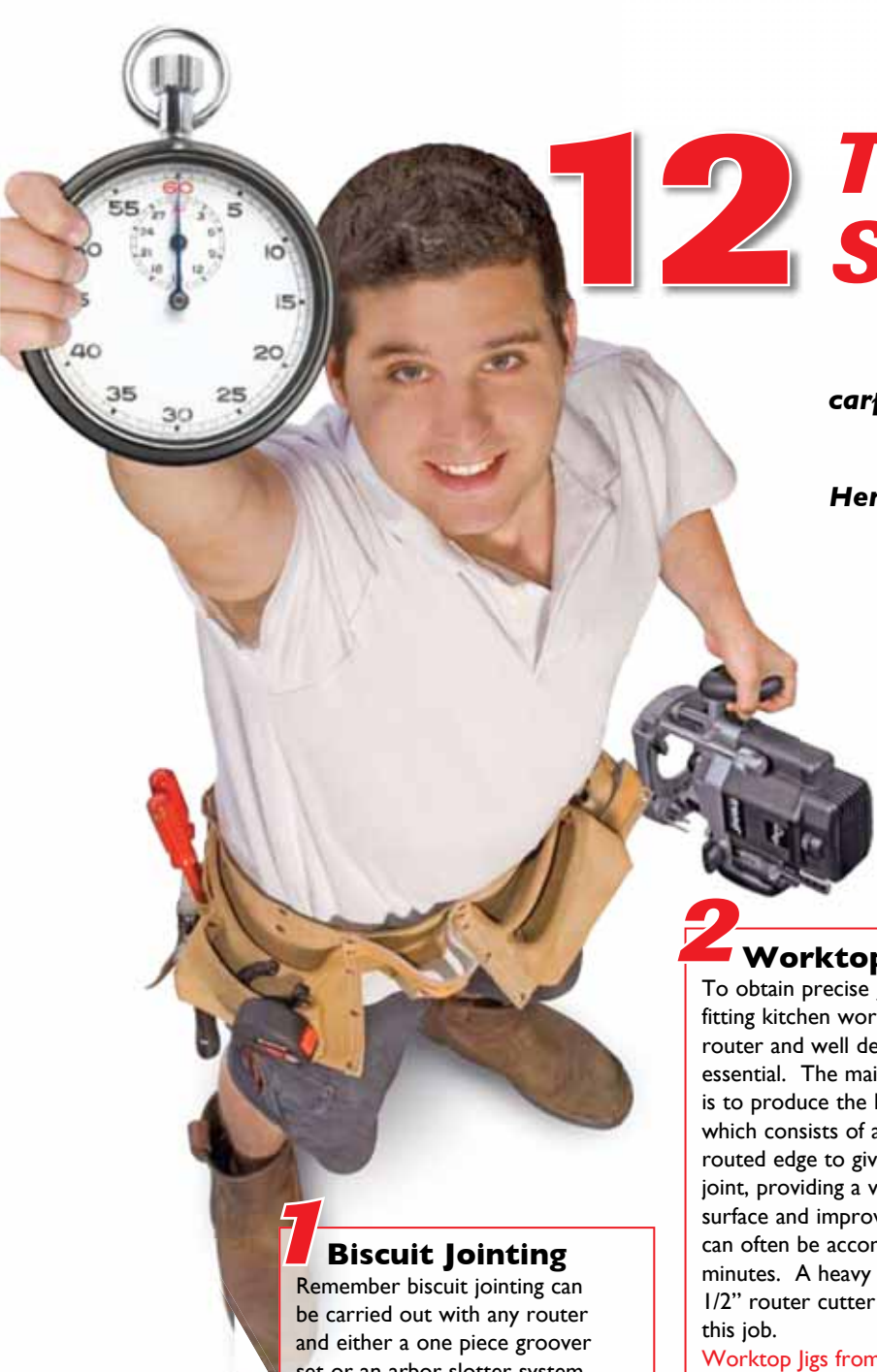

# 12 Time Saving Solutions for the Tradesman

Previously, as an on-site carpenter, I found it vital to keep up with the latest solutions to save time and money onsite. Here are twelve of my favourites.



by Miles Davey

## 1 Biscuit Jointing

Remember biscuit jointing can be carried out with any router and either a one piece groover set or an arbor slotter system. Alternative diameter bearings allow recesses of different depths to be cut to suit the three common biscuit sizes of 0, 10 and also 20. 342 Biscuit Jointer Sets £47.00

Ideal for biscuit jointing kitchen worktops.

## 2 Worktop Jointing

To obtain precise joints when fitting kitchen worktops, a good router and well designed jig are essential. The main use of the jig is to produce the Mason's Mitre which consists of a male and female routed edge to give a near invisible joint, providing a visually continuous surface and improved hygiene. This can often be accomplished within 15 minutes. A heavy duty router and a 1/2" router cutter are required for this job.

Worktop Jigs from £54 to £267

Perfect matching edges.



## 3 Pocket Hole Jig

This is a great method of forming carcass and frame joints. It is both fast and strong. The joint is formed by drilling a screw hole and counterbore at an angle into one of the two pieces to be joined with a stepped drill bit. High torque square socket pan head screws are used to hold the joint together.

PH/JIG £60.50

PH/7X30/500 (500 screws) £8.50



## New Coarse Thread Screws

These new screws have coarser threads and are ideal for softer woods, plywood and particle board with improved security. They come in a 500 pack size No.7 x 30mm.

PH/7X30/500C £12.00



# Tradesman

## 4 Hinge Jig

Having hung 100's of doors myself in my previous career, fitting hinges to doors and then trying to marry them to the door jamb is one of the most time consuming tasks. The Hinge Jig is a portable template set designed for recessing hinges in wooden doors and the frames. With it you can hang a typical door using a router in about 5 minutes. It's easy to use with minimal setting-up time and is very accurate. It now has four apertures, which are placed 6" from the top and 9" from the bottom with one in the middle and a fourth one placed below the top hinge to meet fire door regulations.

Hinge Jigs from £85.00 to £234.00



The hinge itself is used to initially set the length, width and depth of the recess.

Below: The Hinge Jig being used in the frame. Ideally a light or medium duty router is used as it can be tiring work lifting a heavy router.



## 5 The Multiscribe

This 15 multi-functional tool has a very accurate profile and parallel scribing capability and can be used as a T-square, depth gauge and compass.

MS/PRO £31.50



Ideal for profile scribing into irregular contours.

## 6 Clamp Guides

Clamp guides are designed for the accurate guiding of routers, circular saws and jigsaws. Gone are the days of struggling when cutting large sheet material into smaller pieces, with a batten in one hand, and clamps in another. A sliding integral clamping jaw and a cam-locking lever provide a quick way of clamping, giving an obstruction free straight edge.

CGS clamps start from £28.00 to £43.00

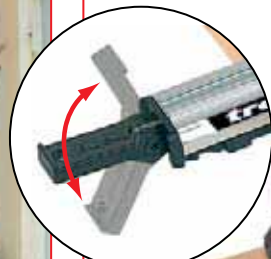

Quick release locking lever secures clamp to workpiece in seconds.



## 7 Lock Jig

The Trend Lock Jig offers a level of precision and finish that is difficult to achieve when cutting lock and latch mortises by hand. The slightest inaccuracy may well result in an ill-fitting lock and a door that is difficult to close. However, using the precision of the router and a jig, the result will be a perfect fit every time. The jig alleviates much of the repetitiveness involved in setting-up and ensures each mortise and its face plate recess are cut square and central across the door edge. Interchangeable templates to suit popular makes of mortise locks, latches and deadlocks are used. It will therefore provide substantial time savings when a number of similar doors require locks fitting.

LOCK/JIG £85.00



Corner chisel for squaring corners of recesses. C/CHISEL £11.00



For routing the leading edges of a door at 3 degrees this cutter is invaluable, Trend Ref. TR38X8MMTC TR39X1/2TC

Trend long reach cutters: TR37X1/2TC TR12X1/4TC

LOCK/JIG/A caters for the new DDA Regulations. N.B. Trend offer a number of additional templates. Please contact our Technical Department for details.



## NEXT STEP

**Voucher Promotion**  
See centrefold for vouchers which can be exchanged at participating Trend stockists.

**FREE Voucher Promotion**

**On-line Knowledge**  
For a wealth of information covering Tradesmen techniques visit the Knowledge section of our website.



www.trend-uk.com

**On-line Video Available**  
For a short video of these products in action.



www.trend-uk.com



## 8 T20 Biscuit Jointer

I've included our dedicated Biscuit Jointer here, the T20, as it offers a robust and efficient means of producing strong and accurate joints in solid timber or timber based boards. It's particularly useful in the construction of unit furniture and carcassing.

T20K (230 volts) £189.00  
T20LK (110 volts) £199.00



Often used for jointing kitchen worktops, it provides strength to the joint to stop the worktop sagging and prevents moisture getting into the core.

NOW IN 110 VOLTS

## 10 Routabout Jig

A very quick way to cut and complete a large access hole in about five minutes. Gives a neat flush finish that won't be noticeable under a fitted carpet. It's safe too as there's no chance of cutting through an electric cable or damaging a water pipe.

Routabout kits start from £44.50



A unique stepped cutter is supplied in the kit.

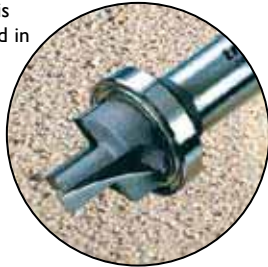

## New Mini Routabout

A smaller version, ideal for plumbers and electricians is now available. It creates a 108mm opening giving access to junction boxes or cables and is ideal for making repairs to accidental damage made to the floor during house construction.

Mini Routabout kits from £40.50



Once the work has been carried out, fill the cut-out with the plastic cover supplied.



Often a 45 minute or one hour fire rating is specified and this requires a 15mm or 20mm groove using cutter Trend Ref. 348 or 345X1/2TC.

## 11 Draining Board Jig

Creating the sloping draining grooves in solid timber worktops next to a Belfast sink is a time consuming and tricky job to undertake without a jig. The spacing and slope angles need to be accurate. This jig has all this built in and will help prevent costly mistakes.

DG/JIG £102.00



A radius cutter is used in a single pass followed by a light clean up pass.



## 12 PRT Router Table

This is the ideal table for on-site use. It fits through a standard door, is light enough to carry, and compact enough to fit in the back of a van. The table also has an optional quick release feature that allows the T11 router to be quickly fitted and removed.

PRT (240 & 115 volts) £475.00  
See pages 28 & 29.



Moulding with the finger pressure guard fitted.



Scribing with the mitre fence and splch block fitted.



# New Cavity Access System



by Neil McMillan

The quicker way for easy underfloor access to pipes and cables.



1 Drill into flooring board

2 Remove waste piece from hole saw and install/retrieve cable

3 Sit steel cover plate inside rebate

Creating access to cables and pipes under chipboard floors. For jobs such as re-wiring or extending power points, or simply fitting a new power shower. This can involve extensive and time consuming work to create the access and then repair the floor afterwards (see right).

We have just launched a new drilling solution for this that works in seconds using an electric drill. The new Access Cavity System allows an access hole of 102mm (4") diameter to be drilled into chipboard flooring.

A specially designed variable pitch bi-metal hole saw with three carbide tipped rebate cutters is attached to a minimum 600 watt 13mm chuck electric drill with side handle. Using a medium to fast speed, this hole saw cuts through up to 22mm of chipboard flooring, and leaves a 2mm rebate to allow a steel cover to replace the wasted piece of floor.

The system includes the hole saw, a heavy duty double pinned arbor with 6.3mm (1/4") drill bit, five steel covers, instructions, a waste disk removal tool, and is supplied in a blow mould case. There are a number of accessories including a pack of 5 steel plates and also a pack of 5 mesh covers. These are used for sealing access holes created in plasterboard walls prior to re-plastering them. An SDS-plus style arbor with drill bit is also available as an optional accessory.



For easy access to electricity cables.



And to pipes underfloor.



For easy access through plasterboard walls.

CAS/KIT £65.00

Accessories

CAS/SC/5 £10.00

Steel cover plates (pack of 5)

CAS/PC/5 £10.00

Mesh covers for plasterboard (pack of 5)

CAS/A/SDS £13.50

SDS+ Shank arbor & pilot drill

## Traditional way

Cut a hole in the chipboard flooring to gain access.

Remove the section of floor without damaging the edges.

Feed the pipes or cables through the access.

Find suitable timber, cut to size, drill and screw along every edge of access hole.

Replace the previously removed section of floor ensuring a flush setting.

Screw the floor section down to the timber supports and test for stability.





# New T60 Cordless Glue Gun

New Cordless Hot-melt Glue Gun with Heating Station and Glue Cartridge.



**W**e have recently launched a new cordless hot-melt glue gun with polyurethane adhesive for a high-strength permanent bond between virtually any materials.

The T60 Glue Gun allows cordless gluing for up to 20

minutes and will bond many materials from wood, plastic and even metal. This cordless flexibility allows the glue gun to be taken to the work, so previously hard to reach areas can now be glued. And no frustrations with that short twisted cable!

The polyurethane glue is housed in a replaceable metal cartridge, which is preheated and therefore allows the glue to be quickly and evenly distributed onto the surface to be bonded. This cartridge also ensures that glue replacement is clean and easy. The initial glue bonding is adjustable for up to 60 seconds, which will allow for minor positional amendments.

The T60 Glue Gun is ideal for jig making, kitchen fitting and for hobby applications, and as it uses a polyurethane glue, it is also suitable for indoor or outdoor use.

It is housed in a heating station complete with drip tray and will reach its warm-up time in approximately 13 minutes. The T60 comes complete with a 50g polyurethane adhesive cartridge and a heating station.

It will appeal to all router users for quick jig making, fixing of support battens and for temporary fixing of workpieces during routing or sanding operations. **IP**

- T60 (240v) \_\_\_\_\_ £79.00
- Polyurethane glue cartridge
- T60/PUR/1 50g (1 off) \_\_\_\_\_ £12.00
- T60/PUR/5 50g (5 off) \_\_\_\_\_ £55.00



Ideal for general hobby use..



..for jig making and component holding while routing.



For wood to wood and man-made boards..



..and for metal to stone.



For kitchen fitting. Up to 60 seconds open time for adjustments.



And suitable for outdoor use.

All prices are exclusive of VAT

Autumn 2009

## FREE CUTTERS WITH ALL TREND ROUTERS

- 3 FREE 1/4" cutters worth approx. £30 with any T4 or T5.
- 2 FREE 1/2" cutters worth approx. £40 with any T10 or T11.



## ALSO TRADE IN YOUR OLD ROUTER AND SAVE UP TO £30

Any Make. Any Model. Any Condition.

**£10** INC. VAT  
TRADE-IN  
VALUE  
OFF A  
T4 ROUTER  
(All models)



**£20** INC. VAT  
TRADE-IN  
VALUE  
OFF A  
T5 ROUTER  
(All models)



**£30** INC. VAT  
TRADE-IN  
VALUE  
OFF A  
T10 ROUTER  
(All models)



**£30** INC. VAT  
TRADE-IN  
VALUE  
OFF A  
T11 ROUTER  
(All models)



Cutter specification may vary. Available while stocks last. Offers valid until 31st January 2010.

For participating stockists [www.trend-uk.com](http://www.trend-uk.com)

**trend**<sup>®</sup>  
routing technology

2008/9 CATALOGUE

Phone 0800 487363 for your free 2008/9 Routing Catalogue and details of your nearest stockist.

web: [www.trend-uk.com](http://www.trend-uk.com) | email: [enquiry@trendm.co.uk](mailto:enquiry@trendm.co.uk)





## On-line Routing

# Hints, Tips and Routing Jigs

We have published a large number of hints and tips for router users on our website. One or two may just make life easier with your next project. Here are a selection..



## NEXT STEP

**Got any jig ideas?**  
If you want to share with others details of any jig you have made, then please email a picture with a brief description. Each published contribution on our website will receive a £20 Trend Gift Voucher.

email: [phillipss@trendm.co.uk](mailto:phillipss@trendm.co.uk)



**On-line Knowledge**  
Please see our website for more hints, tips and routing jig ideas.



**Complete Routing Book**  
This is an essential read for the amateur or experienced router user.



BOOK/CR \_ £21.00

1. Set the clamp in the required position.

### Clamp Guide Offset

If you do a lot of work with a particular router and cutter combination, machine up a piece of thin MDF or plastic to be exactly the same width as the distance between the edge of the router and the required cut line and use this to position the Clamp Guide. It will then be accurate and parallel to the required line.



2. Measure the offset and make the offset gauge.



3. Clamp up with the offset gauge between required cut-line and Clamp Guide.



4. Rout the groove.

### Router Tipping

If you are struggling with the router tipping and a particular cut is critical, clamp a long batten alongside the work to support the router beyond the length of the cut edge. This is a particularly useful tip if you are trying to work on the edge of a very narrow workpiece.



### Widening a Groove

If you need to widen a groove and are just using a single fence, always make the second cut by moving the cutter away from the edge of the work, i.e. to the left, and then feed the router against the rotation of the cutter. Now any deflection of the cutter will be into the pre-cut waste area rather than into the edge and face of the work.



### New Timbers and Materials Glossary on the Trend website

Look up popular materials to find origin, colour, usage etc. Gives routing guide and suitability of material for the job required.



Again we've got a collection of user-made jigs on our website that sometimes make jobs, safer, quicker or more accurate to carry out. Here are just a few..

### Mortising

A way to guarantee consistent identical mortises is to use a slotted template and the router fitted with an appropriate guide bush. These jigs are usually made for specific jobs, but with a little ingenuity you can make a universal template with adjustable stops and locating fences. Simple slot templates can be made for use with a specific guide bush diameter and for specific mortise lengths. Remember that the slot in the template has to be routed to a length equal to the mortise length plus twice the guide bush margin.



### Housing Jig

This simple housing joint is one of the most useful for building shelf units and cabinets. Cutting the necessary groove with a router makes it almost foolproof, providing you can guide the cutter accurately. The jig is made with a heavy section batten which extends well beyond the end of the MDF fence. Use it with a bottom cut two flute cutter and use the base of the router running against the fence as the guide. You must maintain positive pressure against the fence at all times to prevent the cutter wandering off course.

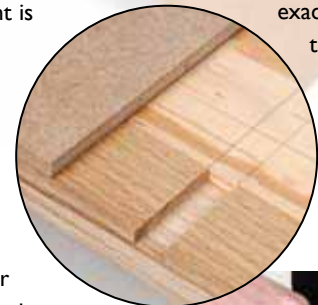

If you don't have a cutter of exactly the right size, then take two passes with a narrower cutter, moving the jig to the required amount between each operation.



### Halving Joint Template

All types of halving joints such as cross, corner, mitred or angled, can be cut with just a straight router cutter and a simple jig.

The use of jigs means that if you are producing repetition work e.g. sets of rails of the same size, the components can usually be stacked and clamped together for cutting in one operation, considerably speeding up production and ensuring complete uniformity.

As the name suggests, halving joints are cut to half the thickness of the rail or batten, leaving the face sides of the joint flush. Usually the components are of equal thickness, though this is not always the case and a halving joint is often used to fit intermediate framing members which are lighter than the main framework. For all halving joints, the router is used with a straight cutter and the depth stop is set to the required depth. **IP**

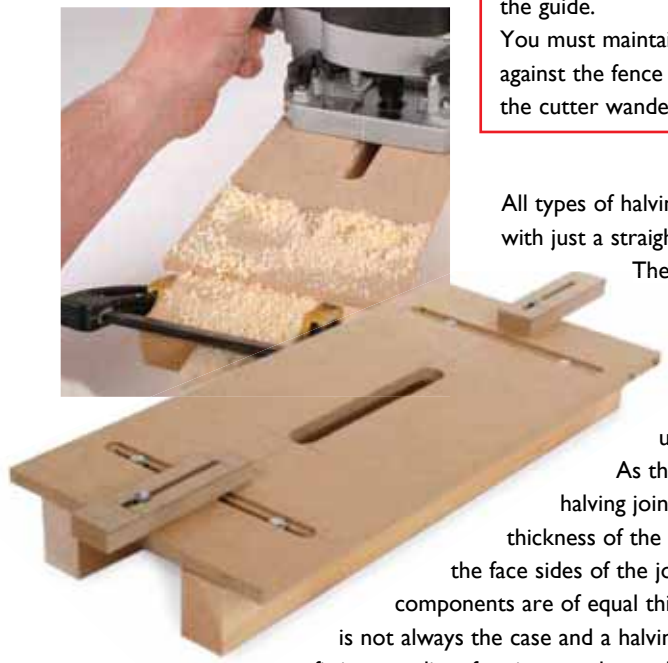



# Furniture 6

## Focus



by Derek Greig

**Jointing and moulding hardwood edgings in carcass construction.**

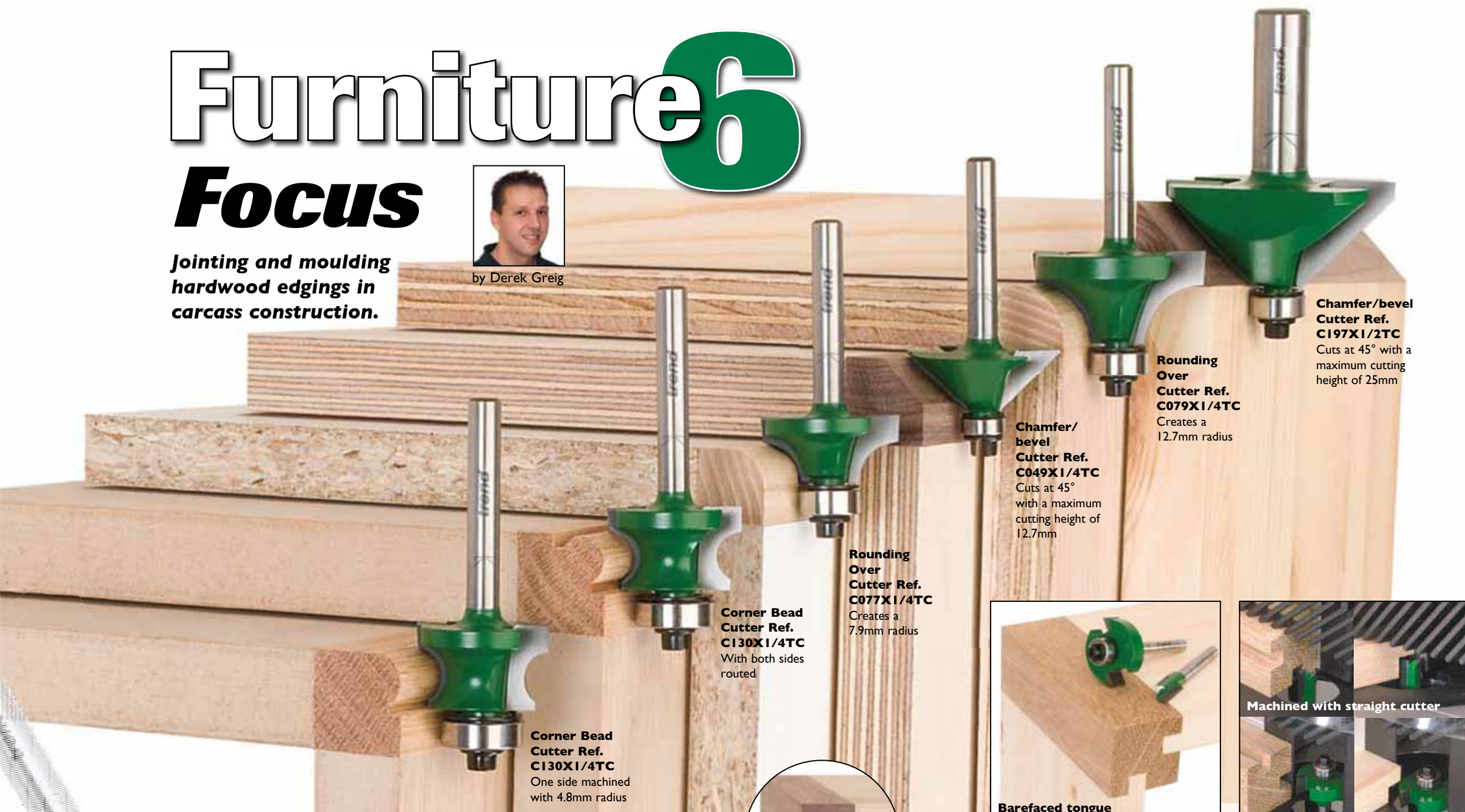

**Chamfer/bevel Cutter Ref. C197X1/2TC**  
Cuts at 45° with a maximum cutting height of 25mm

**Rounding Over Cutter Ref. C079X1/4TC**  
Creates a 12.7mm radius

**Chamfer/bevel Cutter Ref. C049X1/4TC**  
Cuts at 45° with a maximum cutting height of 12.7mm

**Rounding Over Cutter Ref. C077X1/4TC**  
Creates a 7.9mm radius

**Corner Bead Cutter Ref. C130X1/4TC**  
With both sides routed

**Corner Bead Cutter Ref. C130X1/4TC**  
One side machined with 4.8mm radius



**Cutter Ref. C147X1/4TC shown.**

Hardwoods are often used for corner edging in carcass construction as they hide the core material of man-made boards such as plywood, chipboard and MDF. They also provide a robust edge to melamine and veneered surfaces that would otherwise be easily damaged. The hardwood edgings can also be moulded using a variety of different bearing guided cutters without the fear of exposing the core of a board. Often edgings are butt jointed, but for improved strength, tongue and groove joints with loose tongues can be

used. Alternatively, barefaced tongue & groove joints will achieve the same effect. These are easily constructed with straight cutters, slotter cutters or biscuit jointing cutter sets. **TP**



Accurate results can be achieved with a bearing guided slotter or biscuit jointing set working from the face edge of each component. Allow a slight tolerance in the loose tongues for glue.



**Barefaced tongue & groove joint**

For thinner board materials, a barefaced tongue and groove joint may be preferable as it increases the strength of joint compared with a butt joint. This corner joint is easier to produce on a router table. Make sure edges of timber are straight and flat for best results. A splinch block may be needed to prevent breakout when routing the shoulders.

### Loose tongue joint

This provides a strong corner joint with the loose tongue concealed, if required, with a stopped groove. If using a straight cutter, then several passes may be needed to achieve the required mortise depth. Care should be taken when setting the depth of groove to avoid routing the tongue slot too close to the outer surface of the edging. Also avoid machining the slots for the tongues/biscuits so close to each other that the joint is weakened.

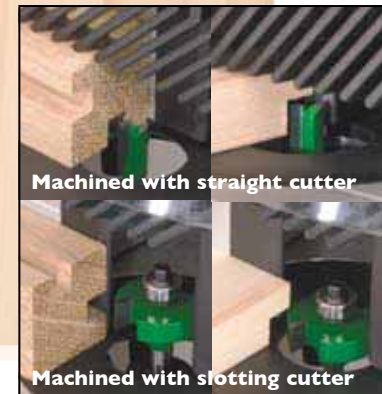

Machined with straight cutter

Machined with slotting cutter

**Trim edging flush with Cutter Ref. C116X1/4TC**

Any overhang on the side or top face can be easily trimmed flush with a bearing guided trimming cutter.

## New Products



### New Airshield Pro Remote Cradle Charger

Allows charging of battery away from the AIR/PRO. Ideal when a spare battery is used. For use with AIR/PRO battery and charger only. AIR/P/7 £27.00



### New Self Centering Mortise Base

This new jig allows a plunge router to rout mortises in the centre of timber components quickly and accurately. It creates round-ended mortises to the same width as the router cutter without the need for marking out. Mortises can be routed in timber up to 100mm wide. Manufactured from a plastic laminate, the Self Centre Mortise Jig has two 30mm long rolling nylon guides, which engage on each side of the timber to self-centre the jig. The nylon rollers provide support and allow a smooth operation. It includes a centre line up bush and is pre-drilled to the Trend TBC hole configuration and will therefore fit directly to the base of Trend/Elu/DeWalt routers. It can also be re-drilled to fit all other router models.

TEMP/SCM/A £25.00





# New Products

## New Diamond Honing Paste & Strop

To give a polished finish to chisels and planer irons, this honing paste and strop kit is an essential kit to keep your tools in tip top condition.

DWS/HP/KIT \_\_\_\_\_ £13.00

### Spares:

DWS/HP/100 \_\_\_\_\_ £9.00

(100g honing paste)

DWS/HP/LS \_\_\_\_\_ £5.50

(leather strop)



## New 'Outdoorsman' Diamond Pen File

This Diamond Pen file has a 600 grit parallel barrel with a flat and a V-groove surface area. It is ideal for sharpening a wide range of small tools and knives. It is also perfect for fish hook sharpening and de-burring. The file is 95mm long and 5.5mm in diameter.

DWS/PFF/F \_\_\_\_\_ £29.50



# Diamond Sharpening Techniques

**Our range of diamond surfaced stones for sharpening, deburring or honing a wide range of tools.**

We have continuously developed and extended our range of diamond sharpening products for sharpening not only router cutters but other woodworking and household tools.

## New Improved Fixed Angle Honing Fasttrack System

Our popular Fasttrack system has been updated with the inclusion of improved performance diamond whetstones.

The 'Fasttrack' is a simple and easy to use portable hand operated sharpening system. Suitable for chisels and planer knives, it creates guaranteed razor fine edges every time.

Made from solid anodised aluminium, it features a quick change magnetic lock which holds the supplied diamond whetstones at the required sharpening angles.

In use, the tool to be sharpened is placed flat on the Fasttrack bed. With a lateral movement, the carriage holding the whetstone, is slid back and forwards across the face of the tool.

The Preparation Stone has been up-rated from 180 to 220 grit and the Finishing Stone up-rated from 400 to 450 grit resulting in fast quality results and improved performance.

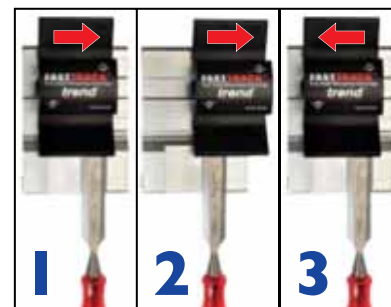

The Fasttrack is available from all Trend stockists. The new improved stones are now available separately.

FTS/KIT \_\_\_\_\_ £53.00



## New Diamond Stone Honing Guide

We have recently launched a valuable addition to our range of Diamond Sharpening products. The Honing Guide ensures that a correct angle is maintained on chisels and plane irons when used with a diamond whetstone.

The main feature of the Honing Guide is a precision roller with alloy body, which self-centre and clamps chisels from 3/8" to 2-1/8" wide.

Chisels are held by each side ensuring that they are always sharpened at 90 degrees. The Honing Guide includes a setting device with pre-sets of 25, 30, 35 and 40 degree angles.

The Honing Guide is easy to use and is ideal for use with diamond bench stones or other workshop stones.

DWS/HG/SET \_\_\_\_\_ £37.50



**Other great diamond sharpening products with a FIVE year guarantee**

## 8"x3" Single-sided Workshop Stones

A single-sided workshop Stone precision flat to +/- 0.0005". Ideal for up to 3" plane irons and chisels. Supplied with a leather pouch, cleaning block and non-slip mat.

DWS/W8/F (fine) \_\_\_\_\_ £82.00

DWS/W8/C (coarse) \_\_\_\_\_ £82.00

## Diamond Pen File Round

This tapered round profile is ideal for turning, carving, knives and small tools, and also useful for removing welds. It has an outer body which becomes the handle and a hook for pocket storage. It is 93mm long and 6mm in diameter.

DWS/PR/F \_\_\_\_\_ £29.50

## 5" & 7" Double-sided Pocket Stones

Double-sided stones with fine and coarse surfaces. The thinner 5" pocket stone is ideal for sawblades, chip limiter router cutters, small tools and carving tools. Supplied with a fabric tool holder and cleaning block.

DWS/P5/FC (5") \_\_\_\_\_ £29.50

DWS/B7/FC (7") \_\_\_\_\_ £87.50

## Diamond Needle Files

Needle files for smaller carving tools, fine tools and removing welds. Suitable for filing metals and plastics. Used extensively in the British aerospace industry.

DWS/NFPK/F (four pack) \_\_\_\_\_ £39.00

Also sold singularly

## Heavy Duty Bench Holder

Adjustable to clamp the 7" or 8" bench stones securely. It will also accept most oil stones up to 8". The extra central rubber block provides additional support.

DWS/BH/B7 \_\_\_\_\_ £15.50

## Diamond Steel

Sharpens all blunt knives easily in seconds with little pressure. Ideal for domestic use, butchery, catering and fishing. It has an exceptional life span having a stainless steel core, electroplated with diamond surface and a polycarbonate handle.

DWS/DS10/F (10") \_\_\_\_\_ £29.50

DWS/DS12/F (12") \_\_\_\_\_ £32.50

## Credit Card Double-sided Stone

A double-sided fine and coarse credit card sized stone. It is ideal for fluted, small and shaped router cutters, woodturning and carving tools. It is supplied in a wallet.

DWS/CC/FC \_\_\_\_\_ £19.50



All prices are exclusive of VAT

Autumn 2009

Autumn 2009

## NEXT STEP

### Voucher Promotion

See centrefold for vouchers which can be exchanged at participating Trend stockists.

### FREE Voucher Promotion

### Diamond Sharpening DVD

DVD/DWS \_ £5.50



### On-line Knowledge

See further information about Diamond Sharpening on our website.



www.trend-uk.com

### On-line Video Available

For a video of diamond products in action.



www.trend-uk.com



# Snappy

## The Quick Release Drill System

The Snappy range is ideal for tackling a wide range of repair, maintenance and construction tasks and in most cases, makes them so much faster and easier to complete. Here is a round up of the latest tools we have added to the Snappy range.

### New Snappy Tool Holder Set

This new 22 piece door hanging tool holder set contains quick change shank tools ideal for fitting locks and hinge fitting. Tools include Snappy Quick Chuck, 2 Drill Bit Guides, 2 Hex drills, 3 flat bits, 12 Pozi®, Phillips® and flat screwdriver insert bits and magnetic screwdriver bit holder.

SNAP/TH4/SET \_\_\_\_\_ £32.50

### New No.2 Pozi® 50mm Screwdriver Bit for Impact Drivers

Pack of three high grade tool steel bits for impact drivers. With a round torsion body for increased life they are ideal for use with high grade screws. Triple pack.

SNAP/PZ/2/ID \_\_\_\_\_ £7.00

### New Snappy Pozi® Bits & Holder

This set comprises of ten 25mm No.2 Pozi® tips and a quick change bit holder. The tips have round shafts to give excellent torque transmission and extended life. They are suitable for No. 6, 8 and 10 screws.

SNAP/IPZ2P/BH \_\_\_\_\_ £8.00

SNAP/BH/58 \_\_\_\_\_ £4.50

(58mm magnetic bit holder only)

### New Snappy Masonry Drill Bits

The range has been increased to include 10mm and 12mm diameter drill bit sizes. Both have a flute length of 95mm and designed for use on soft brick and mortar.

SNAP/MD/10 (10mm) \_\_\_\_\_ £3.75

SNAP/MD/12 (12mm) \_\_\_\_\_ £3.75

### New Keyless Chuck

This is the ideal way to convert existing drilling tools to the Snappy fitting instantly. It has a capacity to take shanks of 0.8mm to 6mm. It is very useful if you have that unusual drill bit or attachment with a repetitive job in hand that requires multiple bit changes.

SNAP/HKLC/6 \_\_\_\_\_ £12.00

### New Offline Driver

Drills and fixes in tight spaces, even next to walls. The outer sleeve rotates allowing secure positioning. The shaft can swivel up to 15°. It will accept both insert bits and direct drive bits and includes a No. 2 Pozi® 50mm bit.

SNAP/OFLD \_\_\_\_\_ £9.00

### New 5 Piece Extra Long Flat Bit Set

This set includes five of the extra long 300mm flat bits with sizes of 16, 18, 22, 25 and 32mm diameters.

SNAP/FB2/SET \_\_\_\_\_ £21.50

### New Flat Bit Extension

This 300mm long extension can be used with Snappy flat bits, auger bits and any Snappy attachments. It can also be used with most ordinary flat bits. Please note, the smallest diameter for flat or auger bit deep drilling is 16mm.

SNAP/FB/EXT \_\_\_\_\_ £7.50

### New 4 Piece Tool Belt and 14" Tote Tool Bag

The four piece tool belt is designed for general tools and has an integral Snappy tool holder. Made from heavy duty polyester with removable pouches.

The purpose designed Snappy tool bag is ideal to hold 2 cordless drills and Snappy tools. It has a rigid metal frame handle and numerous pockets.

SNAP/TBI/SET (Belt) \_\_\_\_\_ £42.00

SNAP/TOTE/I (Bag) \_\_\_\_\_ £27.00

**NOW OVER 350 TOOLS**

**NEXT STEP**

### Voucher Promotion

See centrefold for vouchers which can be exchanged at participating Trend stockists.

**FREE Voucher Promotion**

**On-line Video Available**  
For a short video of the Snappy System in action.



**FREE GIVE-AWAY**

### 50 Free Quick Chucks

We know there are DIYers and woodworkers out there who have just not tried Quick Release tooling. So we are giving away 50 FREE Standard Quick Chucks to the first 50 readers who register on our website. Just go to the catalogue request page at [www.trend-uk.com](http://www.trend-uk.com) & request a 'Give-away Quick Chuck'.

### New Stub Auger Set

Short series auger set with 105mm overall length - ideal for drilling between joists. Made from high quality carbon steel with screw thread and single spur. Recommended for use with torque control drills only. Includes 8, 10, 13, 16, 19, 20, 25, & 32mm sizes.

SNAP/SA1/SET \_\_\_\_\_ £30.00

### Quick Release

Tool release for either the Snappy Quick Chucks or the Impact Driver involves simply pulling back the outer sleeve and removing the tool.

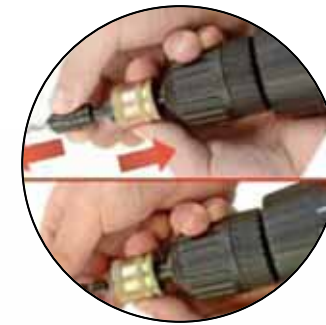

Standard Quick Chuck

SDS+ Shank Quick Chuck

Yankee® Shank Large Quick Chuck

3" Extra Long Chuck

6" Extra Long Chuck

Magnetic Quick Chuck

Hand Driver Set

Tools & accessories not included.



# 7 different styles of window:

## High Performance

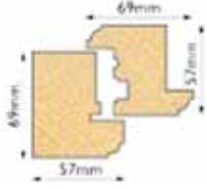

## High Performance 20°

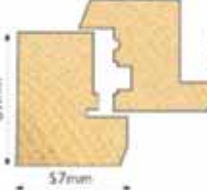

## High Performance Traditional Flush



## Traditional Flush



## Storm Proof



## Sliding Box Sash



## 9° EJMA Style

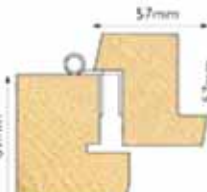

**A complete timber window can be produced quickly and accurately on a spindle moulder with minimal set-up time.**

by Colin Peacock

The demand for timber windows has increased significantly in all sectors of construction with new build, replacement or renovation due to the 'green' credentials of timber windows and concerns over uPVC.

To meet this demand the Modular Window System has been designed for small to medium sized joinery companies, builders and developers enabling them to produce timber windows quickly and accurately on a spindle moulder with a sliding table for a low investment cost.

With this new system the manufacture of any size of window can now be completed in 2-3 labour hours, and not the typical 6-8 hours. This gives the joinery shop the ability to respond quickly and consistently to customer requests and be able to make small quantities of windows in a very cost effective way.

The main benefit of the system is that the fence and spindle height are set once (in seconds with the supplied setting gauge). Then all of the slots, tenons and profiles on the outer frame and sash are machined in one pass without making ANY alterations to the machine. See the simple set-up steps on the right. This dispenses with lengthy set-up and costly test cuts, which requires the concentration of a skilled joiner/machinist and almost invariably reduced profit margins.

All the joints on the outer frame and

sash are slot and tenons but no length stops are required for all operations regardless of size, design or style. All timber sections are simply cut to the required aperture size. The individually numbered steel tools and spacers are stacked onto the spindle according to the steps shown on the supplied wallchart. This helps enormously to speed up the assembly process for each operation and changing the tools takes seconds.

All of the tooling is fitted with, mainly standard, tungsten carbide disposable inserts, giving constant diameters and profiles. Therefore all inserts are available from stock for next day delivery.

Many of the tools are used in more than one of the seven window styles, thus making it even more cost effective for making more than one type of window. So minimal extra tools are required for the new style and not a completely new set. As the accuracy of the joint is built into the tooling dimensions, no test run is required. You can therefore produce a window including sash complete with ironmongery in under three working hours without previous knowledge of window manufacturing (but you must be fully acquainted with spindle moulder operation).

Although each Modular Window System is supplied with step by step wallcharts and manuals, on-site training is also included. **IP**



# Windows By Numbers

## Simple to Set-up

### Set Fence and Spindle Height

The machine's fence and spindle height can be set-up in seconds using the supplied setting gauge.

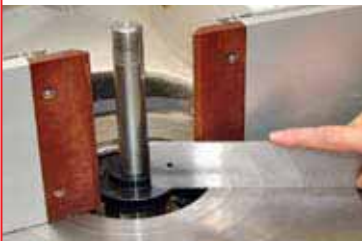

### Slots and Tenons

Machine all the slots and tenons. Thereafter there is no need to alter the fence depth and spindle height.



### Profiles

Machine all the profiles. Again there is no need to alter the fence depth and spindle height.

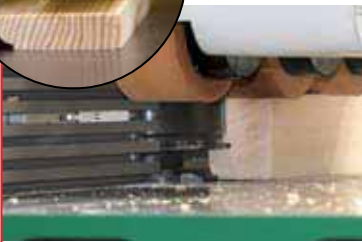

### Clear Numbering

Each tool and spacer is uniquely numbered making it very easy to identify the right tool and set up each stack in seconds.



## MWS Wallcharts

All window systems are clearly numbered with step by step instructions on wallcharts provided.

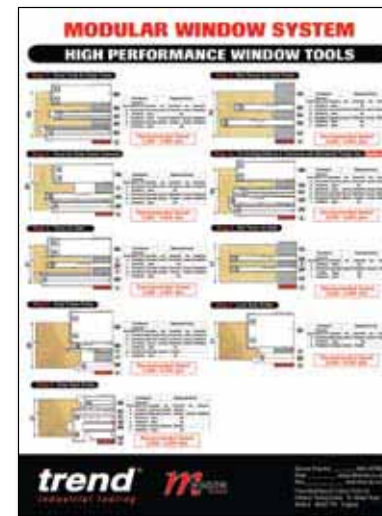

## Spindle Moulder Specification

You can use the Modular Window System with any spindle moulder with the following minimum specifications:

- A sliding table (preferably flush with the machine table).
- A spindle shaft diameter of 30mm or 1-1/4".
- Usable spindle shaft height of 120mm minimum.
- Recommended motor power 7.5HP 3 phase.
- A spindle speed of 3,500 - 9,000 RPM.
- A power Feed (mandatory).
- A 220mm aperture diameter required through the machine table.
- A 240mm diameter required inside the hood and with clear vertical access.



## Example of Slot & Tenon for High Performance Style Windows

The High Performance style of window is one of the most popular. The stack for the Tenon outer frame is shown.

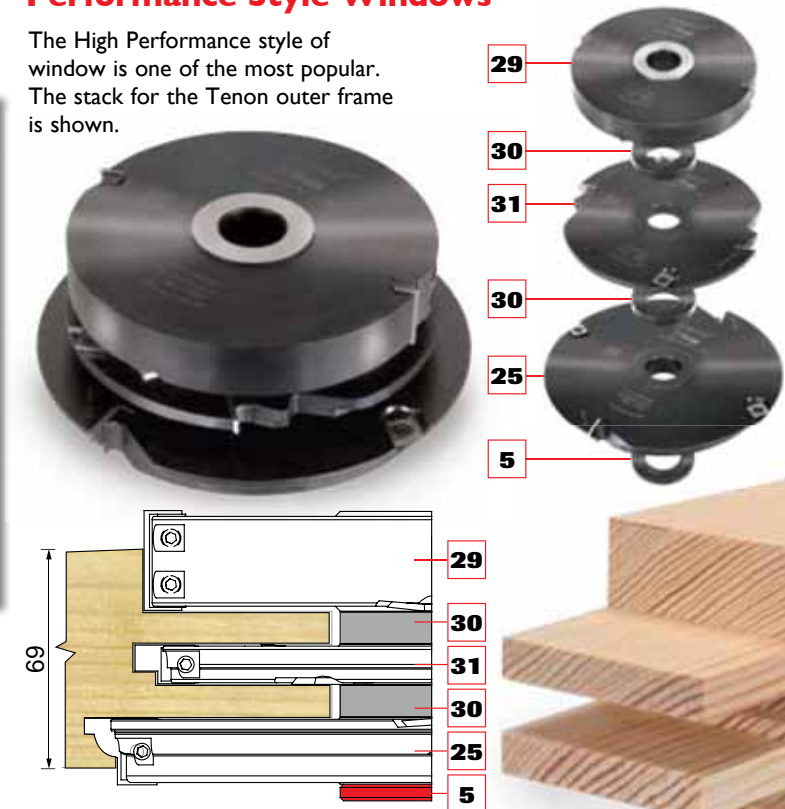

## Example of Outer Frame Profile for High Performance Style Windows

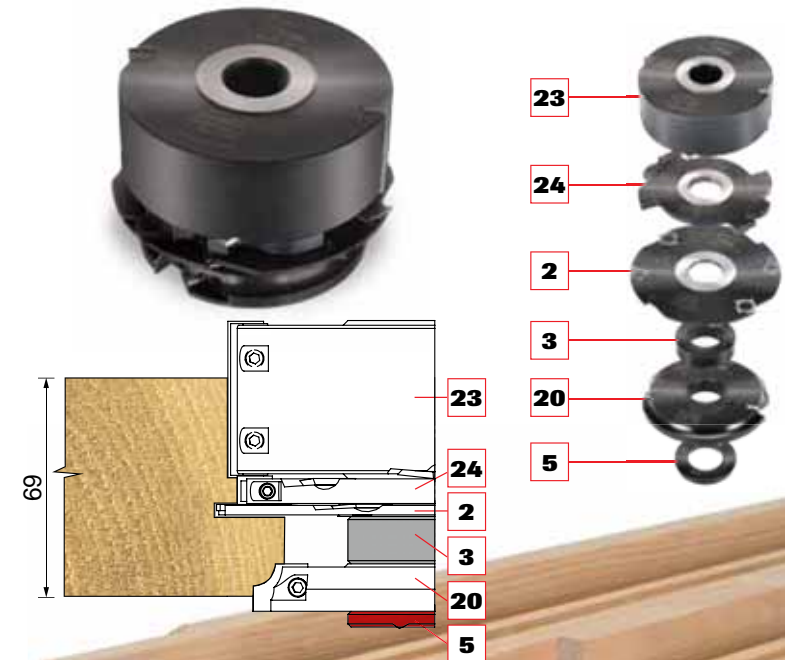

## NEXT STEP

### MWS Brochure

For full information including step by step guide. See centrefold form.



### On-line Video Available

For a video of the Modular Window System in action.



### For advice:

Colin Peacock  
Tel: 07779 803704  
peacockc@trendm.co.uk



# PRT Router Table

A quick overview of the many features of our Professional Router Table.

The PRT router table coupled with a T11 router and T30 dust extractor provides the ultimate router table set-up.

The PRT has a unique extruded 8mm thick aluminium alloy table top for minimal loss of cutter depth and a cutter aperture of 90mm for the largest router cutters available. The table is designed to accept the quick release feature of the T11 router - and the Quick Raiser™ adjuster handle provides above the table height adjustment.

The high power of the T30 dust extractor, fitted with the large diameter hose, provides excellent dust extraction.

Whether floor or bench standing this router table set-up is of a suitable size, and weight, enabling easy re-positioning around the workshop and transportation for on-site use.

## T11 Quick Raiser™

The T11 has a built in fine height adjuster for through table height adjustment.

T11EK and T11ELK \_\_\_\_\_ £345.00

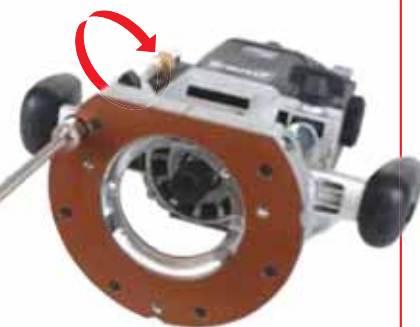

## Back Fence

Quick release, 110mm high cast aluminium back fence with adjustable aluminium cheeks and squareness adjustment.



## Side Finger Pressures

Adjustable position for different widths of timber.

## 4 Insert Rings

In sizes 20mm, 35mm, 54mm & 68mmØ, to suit different cutter diameters.

## Pushstick

With a pushstick park at the rear of the table.

## Power Tool Take Off

With auto-start feature and 6 second run on delay.

## Cable

Extra long 7.8 metre power cable.

## Hose Port

Extra large 57mm diameter hose (optional) for increased suction with table.

## Capacity

Large 34 litre capacity, impact resistant plastic container with 5 castors for stability.

Soft rubber feet to prevent movement.

## The T30 Dust Extractor

Available with standard filter, fine filter or in 115 volts, (max. auto-start 1000 watts)

T30A, T30AF, T30ALF \_\_\_\_\_ from £199

## 57mm Dust Spout Aperture

With freehand lead-on pin park.



## Guard Assembly

Quick lateral and height adjustment of finger pressure and guard.

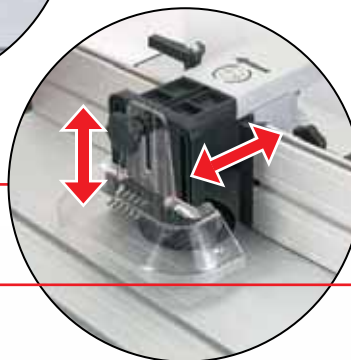

## Large aperture

Extra large 90mm aperture allows the use of the largest router cutters available.

## T Slots

Accepts an M8 nut for fitment of jigs and stops.

## Lead-on Pin

For freehand moulding with bearing guided cutters this safety feature is invaluable.

## Side Scales

On both sides to set back fence.

## No-volt Release Switch

With 115 volt (16amp) version available Ref. PRT/L. Provides immediate access for on/off button and prevents router from re-starting should power supply be turned off.

## PRT Router Table

PRT \_\_\_\_\_ £475

or PRT/L \_\_\_\_\_ £475

(115v max. 1850 watts)

## Bench Leg Level Adjustment

Enabling the table to be levelled on an uneven surface.



## Optional Pushblock

Safely holds rails for scribing panel doors. Includes sliding front stop with grip abrasive and adjustable height toggle clamp.

PUSHBLOCK/4 \_\_\_\_\_ £42.00



## Flip-up Finger Pressure & Guard Assembly

For easy access to cutter.



## Quick Raiser

Includes hole for through the table height adjustment with the T11's Fine Height Adjuster.



## Mitre Fence

Mitre fence with zero setting and splch block facility.



## Three Quick Release Cams for T11

Optional Quick Release Kit includes 3 rotating cams for quick fitting and release of the T11 router.

T11/JT/KIT \_\_\_\_\_ £22





Classic 6 string guitar, Flame Maple top on Padauk neck and body, finished with gold hardware.



# Technology Meets Tradition



by John Tigg

**Organic Guitars in Peterborough had an interesting application for the Trend CNC Smart. Now custom guitars are being constructed using modern technology alongside traditional methods.**

Our CNC team over the years have successfully installed over 250 Smart CNCs in a huge variety of different industries and applications. A number have provided solutions for the manufacturing of complex items such as traditional gun stocks and electric guitars.

One prestigious installation was for Duncan Wales at Organic Guitars who have a very discerning customer base requiring the highest quality in custom electric and bass guitars.

Each custom guitar is initially designed using highly advanced bespoke software to create a virtual model of the guitar to be made. Measurements can then be adjusted, and texture applied to determine the guitars aesthetics. The software can even predict which areas of the body and neck will come under higher levels of tension.

The software then post processes the drawing and creates the G Code files for the Trend CNC Smart machine, ensuring that every cut into the wood is highly accurate.

With the guitar shown above, the main body was made from Padauk with a book matched layer of Flame Maple on the front face. Four holes are first drilled and counterbored to fix the blank on to the jig on the machine. The back is skimmed using a large two flute straight cutter. Two holes are then bored for the engineers dowels to act as index points to ensure that both sides match up perfectly as the blank is flipped over in the jig. Then the curved front surface is routed to receive the 6mm bookmatched Flame Maple. This is glued and left to dry, and clamped down with a shaped clamping plate.

Once dry the body is returned to the jig for the routing of the outside shape and then the numerous recesses

## Advanced Software Design

Blue areas of the picture here are tension-free, moving through the spectrum to red, where the load is at its greatest. The aim is to get reasonably equal colours – and therefore equal tensions – across the length of the fingerboard. All this, without touching a pencil, let alone a piece of wood!

Measurements and contours are entered to create an exact simulation of the guitar, physics are worked out too. Algorithms working inside the software can predict exact tensions across the wood of the guitar, and therefore pre-empt potential weaknesses.

The wonder of technology doesn't stop there. Using texture mapping, the model can be covered in virtual finishes of the various woods. Adjustments can be made in real-time, meaning easy design alterations and the otherwise impossible benefit of chopping and changing parts and woods without any cost in materials.

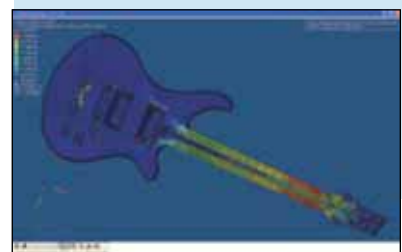

Small wooden tabs hold the guitar to the blank.



Making adjustments to the neck aperture.



including the control cavity, pick up electronics and the neck aperture. Special long reach solid carbide cutters were designed and supplied to Organic Guitars for this application. The ballnose spiral was used for all outside shaping work and the straight spiral for the recesses.

The CNC is left for up to 8 hours to complete all the machining operations required. The small wooden 'tabs' are left intact to hold the body in place during the cutting process, and are subsequently sawn off when their purpose is served.

The ebony fingerboard is also cut out, radiused and recessed with another program. An ingenious jig tilts the workpiece when the headstock is machined to provide the necessary angle.

Grooves are recessed in the finger board which is glued onto the neck once the truss rod is

installed. A very small solid carbide spiral cutter is used to machine out the Organic logo to a depth of 0.5mm. This is filled later with gold leaf to give an exquisite effect.

The neck joint is a particularly important part of the construction process, and affects both the structural integrity and natural sustain of any guitar. Construction relies on maximum wood-on-wood contact with little glue required, so when it comes to the



The Organic Guitar logo is machined out using a very small solid carbide spiral cutter before it is gold leafed.

neck and body joint, high tolerances are required. However once the neck is pushed in, a 'feeler gauge' is used all around the exposed joints to search for gaps - any discrepancies are worked with a chisel. Once things are absolutely perfect, the neck can be properly set with Aliphatic Resin glue.

Finally the whole guitar is hand finished, as although the finish on the CNC is good, the ultimate surface is required before the final product is oiled. **IP**

Please visit the Organic Guitars website for full details of their guitars.

[www.organicguitars.co.uk](http://www.organicguitars.co.uk)

## Other Applications

### Tool Management Systems

A number of our CNC Smart installations have been for the production of foam inserts for tool cases and chests. These are fitted with a two colour foam machined to accept specific tools for the control of tools used in aircraft maintenance.

The installation required bespoke tool control software which generates the optimum layout of the tools for the size of the drawer and the design is converted into toolpaths for the CNC Smart machines.

Another installation used six CNC Smart plus machines producing foam trays for an extensive range of mechanics and engineering tools. All six machines are worked by one operator. Here the design of the foam is carried out using Art Cam Insignia with vacuum tables holding the foam in place while machining.

### Student Training

We have also installed many of the CNC Smart machines into schools and colleges. A recent installation was in the new prestigious South Lanarkshire College in East Kilbride opened by Princess Anne. The Building Faculty installed the 'CNC Smart Plus' machining centre. Using Art Cam Insignia to design and post process the files for the machine, students are now able to manufacture a varied number of components for their projects. These include doors for small cabinets and various jigs for use with the hand router and spindle moulder. The installation of the machine will enable the college to offer machine woodworking qualifications now that they have the CNC capability.

### Organ Component Production

We have also installed CNC machines into factories for the production of keyboards, pedal boards and decorative panel work for traditional and electronic organs which have components of a very complex nature.



## New CNC SMART Y1300

New high performance floor mounted machine for improved routing productivity with wide bed of 1320mm.



### CNC Smart Brochure

For information on all our CNC Machines see centrefold form.

### On-line Video Available

For a video of the CNC Smart in action at Oakham School in Rutland.



For advice: John Tigg  
Tel: 07802 247350 [tiggj@trendm.co.uk](mailto:tiggj@trendm.co.uk)



# T60 CORDLESS GLUE GUN

## Cordless hot-melt glue gun with heating station

- Polyurethane glue for bonding ceramics, marble, metal, glass, wood, various plastics\*, leather & textiles.
- 15 - 20 minutes working time after heating up.
- Immediate high initial bond with an open time of up to 60 seconds to allow for adjustments.
- High final bond strength increases after initial fixing.
- Glue cartridge design allows for greater heat spread for easier gluing.

\*Not for use with PP, PE, polystyrene and silicon.

## Take the Glue to the Work!



Heating Station



50g Glue  
Cartridge Included



Jig Making



Wood to Wood

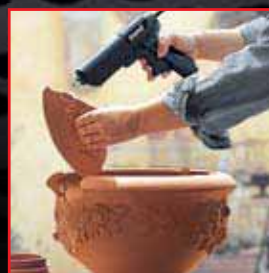

Outdoor Use

For more information visit [www.trend-uk.com](http://www.trend-uk.com)

**trend**<sup>®</sup>  
routing technology



**2008/9 CATALOGUE**

Phone 0800 487363 for your free 2008/9 Routing Catalogue and details of your nearest stockist.

web: [www.trend-uk.com](http://www.trend-uk.com) | email: [enquiry@trendm.co.uk](mailto:enquiry@trendm.co.uk)