



**ORIGINAL
INSTRUCTIONS**

WRT



trend[®]
routing technology



Please read these instructions before use.
Failure to follow the warnings and instructions may result in electric shock, fire and/or serious injury.

Dear Customer

Thank you for purchasing this Trend product, we hope you enjoy many years of creative and productive use.

Please remember to return your guarantee card within 28 days of purchase.

Please read these instructions before use.

CONTENTS

TECHNICAL DATA _____	1
SAFETY _____	2-3
ELECTRICAL SAFETY _____	4
EC DECLARATION OF CONFORMITY _____	5
ITEMS ENCLOSED _____	5
DESCRIPTION OF PARTS _____	6
ASSEMBLY _____	7-17
- Router Compatibility _____	9
- Mounting Router to Insert Plate _____	10
- Mounting Table to Workbench _____	11
- Mounting No Volt Release Switch _____	11
- Levelling the Insert Plate _____	12
- Fitting Insert Rings _____	12
- Fitting Back Fence _____	13
- Fitting Guards _____	14-15
- Fitting Mitre Fence and Pushstick _____	16
- Fitting Cable Management Clips _____	17
OPERATION	
- No-Volt Release Switch _____	18
- Back Fence Adjustment _____	19
- Edge Moulding and Grooving _____	20
- Stopped Moulding _____	21
- Mitre Fence _____	22
- Lead-On Pin _____	23
- Edge Planing _____	23
ACCESSORIES _____	25
MAINTENANCE _____	26
ENVIRONMENTAL PROTECTION _____	26
GUARANTEE _____	26
SPARE PARTS	
- Spare Parts List _____	27-28
- Spare Parts Diagram _____	IB

Definitions: Safety Guidelines

The definitions below describe the level of severity for each signal word. Please read the manual and pay attention to these symbols.

The following symbols are used throughout this manual:

 **WARNING:** indicates a potential hazardous situation which, if not avoided, **could** result in **death or serious injury**.

 **CAUTION:** Indicates a potentially hazardous situation which, if not avoided, may result in **minor or moderate** injury.

NOTICE: Indicates a practice **not related** to **personal injury** which, if not avoided, **may** result in **property damage**.



Denotes risk of electric shock.



Denotes risk of fire.

Additional Symbols Used



Wear Personal Protective Equipment (PPE). Ear, eye and respiratory protection **must** be worn.



Denotes risk of personal injury, loss of life or damage to the tool in case of non-observance of the instructions in this manual.



Refer to the instruction manual of your power tool.



If you require further safety advice, technical information or spare parts, please call Trend Technical Support or visit www.trend-uk.com

**ROUTER TABLE
WRT**

TECHNICAL DATA

Voltage	UK & Eire	V _{AC}	240
	Europe	V _{AC}	230
On/off switch			No-volt release
Dimensions	Width x depth	mm	804 x 604
		mm	840
Table height		mm	840
Cutter diameter max.		mm	86
Cutter height max.		mm	55
Loss of cutting depth due to table thickness		mm	6.35
Workpiece height max.		mm	60
Workpiece length max.*		mm	800
Weight		kg	27.5

*Unless a workpiece support is used.

Fuses

UK & Eire	240V tools	13 Amperes, in plug
Europe	230V tools	10 Amperes, in mains

INTENDED USE

The unit is intended for stationary operation of portable routers for the cutting of wood or wood based material when suitable cutter is fitted. It is not intended for continuous production or production line use.

This unit must not be put into service until it has been established that the power tool to be connected to this unit is compliance with 2006/42/EC (identified by the CE marking on the power tool).

This router table is a professional product.

DO NOT use under wet conditions or in presence of flammable liquids or gases.

DO NOT let children come into contact with this appliance. Supervision is required when inexperienced operators use this appliance.

This product is not intended for use by persons (including children) suffering from diminished physical, sensory or mental abilities ; lack of experience, knowledge or skills unless they are supervised by a person responsible for their safety. Children should never be left alone with this product.

SAFETY



WARNING:

Observe the safety regulations in the instruction manual of the power tool to be used. Please read the following instructions carefully. Failure to do so could lead to serious injury. When using electric tools, basic safety precautions, including the following should always be followed to reduce the risk of fire, electric shock and personal injury. Also observe any applicable additional safety rules. Read the following safety instructions before attempting to operate this product.

PLEASE KEEP THESE INSTRUCTIONS IN A SAFE PLACE.

The attention of UK users is drawn to the Provision and Use of Work Equipment Regulations 1998, and any subsequent amendments.

Users should also read the HSE/HSC Safe Use of Woodworking Machinery Approved Code of Practice and Guidance Document and any amendments.

Users must be competent with woodworking equipment before using our products.

IMPORTANT NOTE:

Residual Risk. Although the safety instructions and operating manuals for our tools contain extensive instructions on safe working with power tools, every power tool involves a certain residual risk which cannot be completely excluded by safety mechanisms. Power tools must therefore always be operated with caution!

General

1. Disconnect power tool and attachment from power supply when not in use, before servicing, when making adjustments and when changing accessories such as cutters. Ensure switch is in "off" position. Always ensure cutter has stopped rotating.
2. Always mount the power tool, accessory or attachment in conformity with the instructions. Only use attachment and accessories specified in the power tool manual. The tool or attachment should not be modified or used for any application other than that for which it was designed. Do not force tool.
3. Keep children and visitors away. Do not let children or visitors touch the tool, accessory or attachment. Keep children and visitors away from work area. Make the workshop child proof with padlock and master switch.
4. Dress properly. Do not wear loose clothing or jewellery, they can be caught in moving parts. Rubber gloves and non-skid footwear is recommended when working outdoors. Wear protective hair covering to contain long hair.
5. Consider working environment. Do not use the product in the rain or in a damp environment. Keep work area well lit. Do not use power tools

near gasoline or flammable liquids. Keep workshop at a comfortable temperature so your hands are not cold. Connect machines that are used in the open via a residual current device (RCD) with an actuation current of 30 mA maximum. Use only extension cables that are approved for outdoor use.

6. The accessory or attachment must be kept level and stable at all times.
7. Keep work area clean. Cluttered workshops and benches can cause injuries. Ensure there is sufficient room to work safely.
8. Secure idle tools. When not in use, tools should be stored in a dry and high or locked up place, out of reach of children.
9. For best control and safety use both hands on the power tool and attachment. Keep both hands away from cutting area. Always wait for the spindle and cutter to stop rotating before making any adjustments.
10. Always keep guards in place and in good working order.
11. Remove any nails, staples and other metal parts from the workpiece.
12. Maintain tools and cutters with care. Keep cutters sharp and clean for better and safer performance. Do not use damaged cutters. Follow instructions for lubricating and changing accessories. Keep handles dry, clean and free from oil and grease.
13. Maintain accessories. Do not use damaged accessories. Only use accessories recommended by the manufacturer.
14. Check damaged parts. Before operation inspect the attachment, the power tool, the cable, extension cable and the plug carefully for signs of damage. Check for alignment of moving parts, binding, breakage, mounting and any other conditions that may effect its operation. Have any damage repaired by an Authorised Service Agent before using the tool or accessory. Protect tools from impact and shock.
15. Do not use tool if switch does not turn it on or off. Have defective switches replaced by an Authorised Service Agent.
16. Don't over reach. Keep proper footing and balance at all times. Do not use awkward or uncomfortable hand positions.
17. Don't abuse the cable. Never carry power tool or accessory by cord or pull it to disconnect from the socket. Keep cord from heat, oil and sharp edges. Always trail the power cord away from the work area.
18. Connect dust extraction equipment. If devices are provided for the connect-

tion of dust extraction and collection facilities, ensure these are connected and properly used.

19. Check all fixing and fastening nuts, bolts and screws on power tool, attachment and cutting tools before use to ensure they are tight and secure. Periodically check when machining over long periods.
20. Stay alert. Watch what you are doing. Use common sense. Do not operate tools when you are tired, under the influence of drugs or alcohol.
21. Personal Protective Equipment (PPE) for eye, ear and respiratory protection must be worn. All PPE must meet current UK and EU legislation.
22. Do not leave tools running unattended. Do not leave tool until it comes to a complete stop.
23. Always clamp workpiece being machined securely.
24. Only use cutting tools for wood-working that meet EN847-1/2 safety standards, and any subsequent amendments.
25. Vibration levels. Hand held power tools produce different vibration levels. You should always refer to the specifications and relevant Health & Safety Guide.

Routing Safety

1. Read and understand instructions supplied with power tool, attachment and cutter.
2. Keep hands, hair and clothing clear of the cutter.
3. Remove adjusting keys and spanners. Check to see that keys and adjusting spanners are removed from the router tool, cutter and attachment before turning router on. Make sure cutter can rotate freely.
4. Noise. Take appropriate measures for the protection of hearing if the sound pressure of 85dB(A) is exceeded. Routing sound pressure may exceed 85dB(A), so ear protection must be worn.
5. Eye protection. Always wear eye protection in the form of safety goggles, spectacles or visors to protect the eyes.
6. Respiratory protection. Always wear a face or dust mask, or powered respirator. Dust masks/filters should be changed regularly.
7. Do not switch router on with the cutter touching the workpiece. At the end of the cut, release the router plunge and allow spindle to stop rotating. Never use the spindle lock as a brake
8. The direction of routing must always be opposite to the cutter's direction of rotation. Do not back-cut or climb-cut.
9. Check before cutting that there are no obstructions in the path of the

router. Ensure there are no obstacles beneath workpiece when cutting full thickness, and that a sacrificial work surface is used.

10. Hold power tool by insulated gripping surfaces, because the cutter may contact its own cord. Cutting the "live" wire may make exposed metal parts of the powertool "live" and shock the operator.
11. Use clamps or another practical way to secure and support the workpiece to a stable platform. Holding the work by your hand or against the body leaves it unstable and may lead to loss of control.

Router Cutter Safety

1. Cutting tools are sharp. Care should be taken when handling them. Do not drop cutters or knock them against hard objects. Handle very small diameter cutters with extra care. Always return cutter to its packaging after use.
2. Always use cutters with a shank diameter corresponding to the size of the collet installed in your tool.
3. The maximum speed (n.max) marked on the tool, or in instructions or on packaging shall not be exceeded. Where stated the speed range shall be adhered to. Recommended speeds are shown in the Trend Routing Catalogue and/or website.
4. Always use router cutters in a router. Drill and boring bits must not be used in a router. Router cutters must only be used for the material cutting application for which they are designed. Do not use on metal or masonry.
5. Never use cutters with a diameter exceeding the maximum diameter indicated in the technical data of the powertool or attachment used.
6. Before each use check that the cutting tool is sharp and free from damage. Do not use the cutting tool if it is dull, broken or cracked or if in any other damage is noticeable or suspected.
7. Cutters should be kept clean. Resin build up should be removed at regular intervals with Resin Cleaner. The use of a PTFE dry lubricant will reduce resin build up. Do not use PTFE spray on plastic parts.
8. When using stacked tooling (multi-blade, block and groover etc.) on a spindle arbor, ensure that the cutting edges are staggered to each other to reduce the cutting impact.
9. Cutter shanks should be inserted into the collet all the way to the line indicated on the shank. This ensures that at least ¾ of the shank length is held in the collet. Ensure clamping surfaces are cleaned to remove dirt, grease, oil and water.
10. Observe the correct assembly and

fitting instructions in the router instruction manual for fitting the collet, nut and cutter.

11. Tool and tool bodies shall be clamped in such a way that they will not become loose during operation. Care shall be taken when mounting cutting tools to ensure that the clamping is by the shank of the cutting tool and that the cutting edges are not in contact with each other or with the clamping elements.
12. It is advisable to periodically check the collet and collet nut. A damaged, worn or distorted collet and nut can cause vibration and shank damage. Do not over-tighten the collet nut
13. Do not take deep cuts in one pass; take several shallow or light passes to reduce the side load applied to the cutter and router. Too deep a cut in one pass can stall the router.
14. In case of excessive vibrations whilst using the router stop immediately and have the eccentricity of the router, router cutter and clamping system checked by competent personnel
15. All fastening screws and nuts should be tightened using the appropriate spanner or key and to the torque value provided by the manufacturer.
16. Extension of the spanner or tightening using hammer blows shall not be permitted.
17. Clamping screws shall be tightened according to instructions provided by the manufacture. Where instructions are not provided, clamping screws shall be tightened in sequence from the centre outwards.
18. Do not touch the cutter immediately after operation; it may be extremely hot and could burn your skin.

Using Routers In A Fixed Position

1. Attention should be made to the HSE's Safe Use of Vertical Spindle Moulding Machines Information Sheet No.18 and any revisions.
2. After work, release the router plunge to protect the cutter.
3. Always use a push-stick or push-block when making any cut less than 300mm in length or when feeding the last 300mm of the cut.
4. The opening around the cutter should be reduced to a minimum using suitably sized insert rings in the table and closing the back fence cheeks or fitting a false fence on the back fence.
5. Whenever possible use a work holding device or jig to secure component being machined. Ensure any attachment is securely fitted to the workbench, with table surface at approximately hip height.
6. Use a No-Volt Release Switch. Ensure

it is fixed securely, easily accessible and used correctly.

7. In router table (inverted) mode, stand to the front right of the table. The cutter will rotate anti-clockwise when viewed from top so the feed direction is from the right (against the rotation of the cutter). In overhead mode, stand to the front left of the machine table and the feed direction is from the left.
8. Do not reach underneath table or put your hands or fingers at any time in the cutting path while tool is connected to a power supply.
9. Never thickness timber between the back of the cutter and the backfence.

Useful Advice When Routing

1. Judge your feed rate by the sound of the motor. Feed the router at a constant feed rate. Too slow a feed rate will result in burning.
2. Trial cuts should be made on waste material before starting any project.
3. When using some attachments e.g. a router table or dovetail jig, a fine height adjuster is recommended.
4. When using a template guide bush, ensure there is sufficient clearance between cutter tip and inside edge of bush and that it cannot come into contact with collet and nut. Ensure cutter and guide bush are concentric.

Router Cutter Repair/Maintenance

1. Repair of tools is only allowed in accordance with the manufacturers instructions.
2. The design of composite (tipped) tools shall not be changed in process of repair. Composite tools shall be repaired by a competent person i.e. a person of training and experience, who has knowledge of the design requirements and understands the levels of safety to be achieved.
3. Repair shall therefore include, e.g. the use of spare parts which are in accordance with the specification of the original parts provided by the manufacturer.
4. Tolerances which ensure correct clamping shall be maintained.
5. Care shall be taken that regrinding of the cutting edge will not cause weakening of the body and the connection of the cutting edge to the body.

Version 8.0 08/2017

ELECTRICAL SAFETY



**Mains Plug Replacement
(UK & Ireland only)**

Always check the condition of the cable and plug before starting with your work.

Should your mains plug need replacing and you are competent to do this, proceed as instructed below. If you are in doubt, contact an authorised Trend repair agent or a qualified electrician.

- Disconnect the plug from the supply.
- Cut off the plug and dispose of it safely; a plug with bared copper conductors is dangerous if engaged in a live socket outlet.
- Only fit 13 Amperes BS 1363A approved plugs fitted with a 13 Amp A.S.T.A approved BS 1362 fuse (1).
- The cable wire colours, or a letter, will be marked at the connection points of most good quality plugs. Attach the wires to their respective points in the plug (see below). Brown is for Live (L) (2) and Blue is for Neutral (N) (3).
- Before replacing the top cover of the mains plug ensure that the cable restraint (4) is holding the outer sheath of the cable firmly and that the two leads are correctly fixed at the terminal screws.

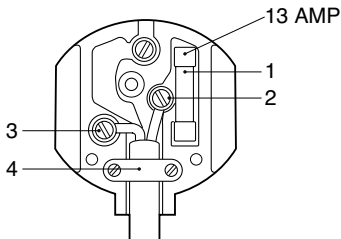

Never connect the live (L) or neutral (N) wires to the earth pin marked E or \perp

Using an Extension Cable

- If an extension cable is required, use an approved triple core extension cable suitable for the power input of this tool (see technical data). The minimum conductor size is 1.5mm².
- When using a cable reel, always unwind the cable completely.
- Also refer to the table below.

Conductor size (mm ²)	Cable rating (Amperes)
0.75	6
1.00	10
1.50	15
2.50	20
4.00	25

Voltage	Amperes	Cable length (m)					
		7.5	15	25	30	45	60
230	0 - 2.0	6	6	6	6	6	6
	2.1 - 3.4	6	6	6	6	6	6
	3.5 - 5.0	6	6	6	6	10	15
	5.1 - 7.0	10	10	10	10	15	15
	7.1 - 12.0	15	15	15	15	20	20
	12.1 - 20.0	20	20	20	20	25	-

WARNING: Never use a light socket.

EC DECLARATION OF CONFORMITY

MACHINERY DIRECTIVE



**ROUTER TABLE
WRT**

Trend declares that the attachment described under Technical Data is in compliance with 2006/42/EC, and has been designed in accordance with EN12100:2010, EN62841-1:2015, EN60745-2-17:2010 Annex M.

The tool also complies with Directives 2014/30/EU and 2011/65/EU.

Pushstick is made in compliance with Harmonized Standard EN 1870-19:2013.

For more information please contact Trend at the following address or refer to back of manual. The undersigned make this declaration on behalf of Trend Machinery & Cutting Tools Ltd.

Technical Director
Neil McMillan

Trend Machinery & Cutting Tools Ltd
Unit 6 Odhams Trading Estate
St Albans Road, Watford
Herts, WD24 7TR
United Kingdom
01.01.2018

RESIDUAL RISKS

In spite of the application of the relevant safety regulations and implementation of safety devices, certain residual risks cannot be avoided. These are:-

- Impairment of hearing.
- Risk of personal injury due to flying particles.
- Risk of burns due to accessories becoming hot during operation.
- Risk of personal injury due to prolonged use

MARKINGS ON TABLE

The following pictures are shown on the tool.



Read instruction manual before use.

Date Code Position

The year of manufacture is on a label next to the rating plate.

ITEMS ENCLOSED

- 1 x Table top
- 4 x Legs
- 4 x Leg rails
- 4 x Feet
- 1 x Back fence and scale
- 2 x Fence cheeks
- 4 x Fence cheek knobs
- 1 x Top guard, top pressure and fixing knob assembly
- 1 x Dust spout and fixing screws
- 2 x Back fence fixing knobs and bolts
- 1 x Side pressure and fixing knob assembly
- 2 x Edge planing rods
- 2 x Edge planing rod locking knob assemblies
- 8 x Leg rail fixing screws and washers
- 4 x Frame to top fixing screws and washers
- 1 x Insert plate and fixing screws
- 1 x No-volt release switch brackets and fixing screws
- 1 x Mitre fence assembly
- 2 x Insert rings
- 1 x Lead-on pin
- 1 x Pushstick
- 2 x Table top scales (fitted)
- 1 x T11 Quick Raiser handle park pin
- 2 x Cable management clips and screws
- 1 x Accessory hooks
- 1 x Hex key 3mm A/F
- 1 x Hex key 4mm A/F
- 1 x Router screw fixing pack
- 1 x Instructions
- 1 x Guarantee card
- Check for damage to the tool, parts or accessories which may have occurred during transport.
- Take the time to thoroughly read and understand this manual prior to operation.

DESCRIPTION OF PARTS

- | | | | |
|------------------|----------------------|---------------------------------------|-----------------------------------|
| (A) Legs | (J) Switch | (S) Hex key 3mm AF | (Z) Router fixing screw pack |
| (B) Insert plate | (K) Pushstick | (T) Edge planing rod | (AA) T11 Quick Raiser handle park |
| (C) Table top | (L) Insert rings | (U) Edge planing rod locking assembly | (AB) Manual |
| (D) Back fence | (M) Table top scales | (V) Backfence scale | (AC) Guarantee card |
| (E) Fence cheek | (N) Side pressure | (W) Cable management clips | |
| (F) Top pressure | (O) Dust spout | (X) Leg rails long | |
| (G) Top guard | (P) Feet | (Y) Leg rails short | |
| (H) Lead-on pin | (Q) Lead-on pin park | | |
| (I) Mitre fence | (R) Accessory hook | | |

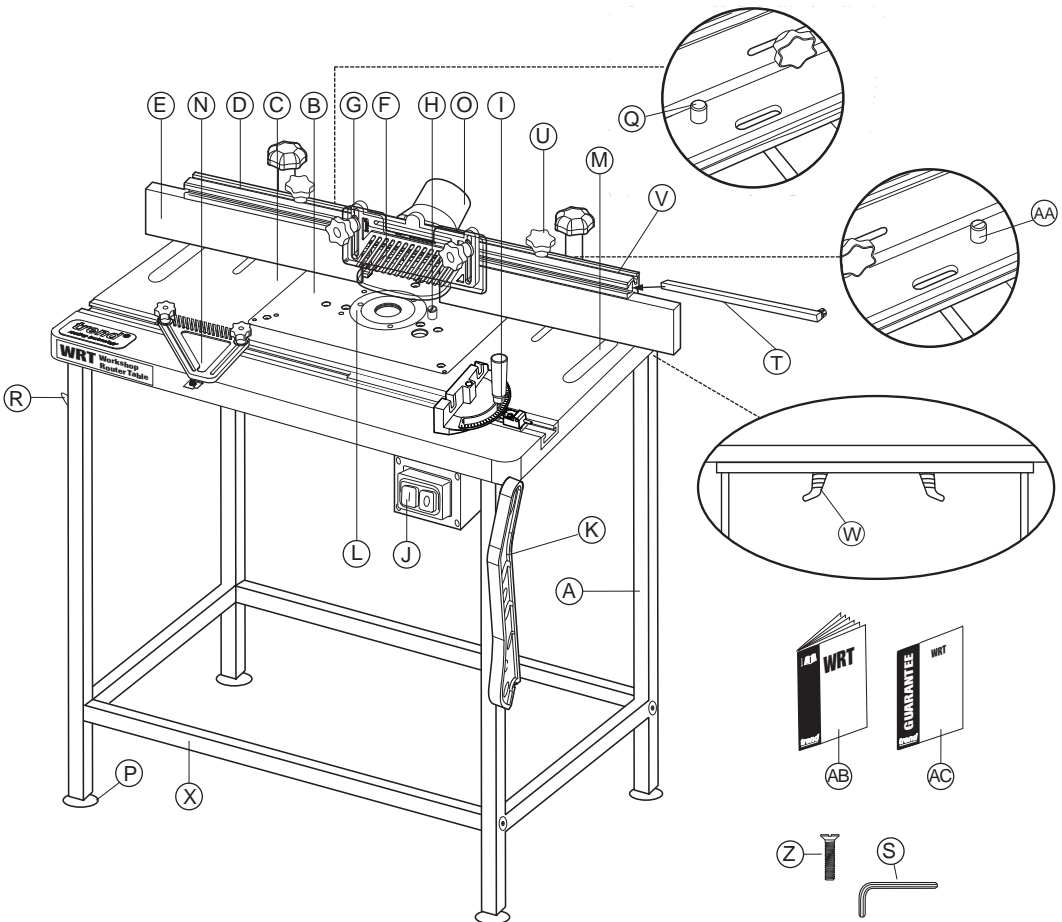

ITEMS REQUIRED

- Phillips[®] No.2. screwdriver.
- Router.
- Hand tools.
- User made bench.
- Slotted screwdriver for lead on pin.

ASSEMBLY

Assembly of Table and Leg Frame

(overview)

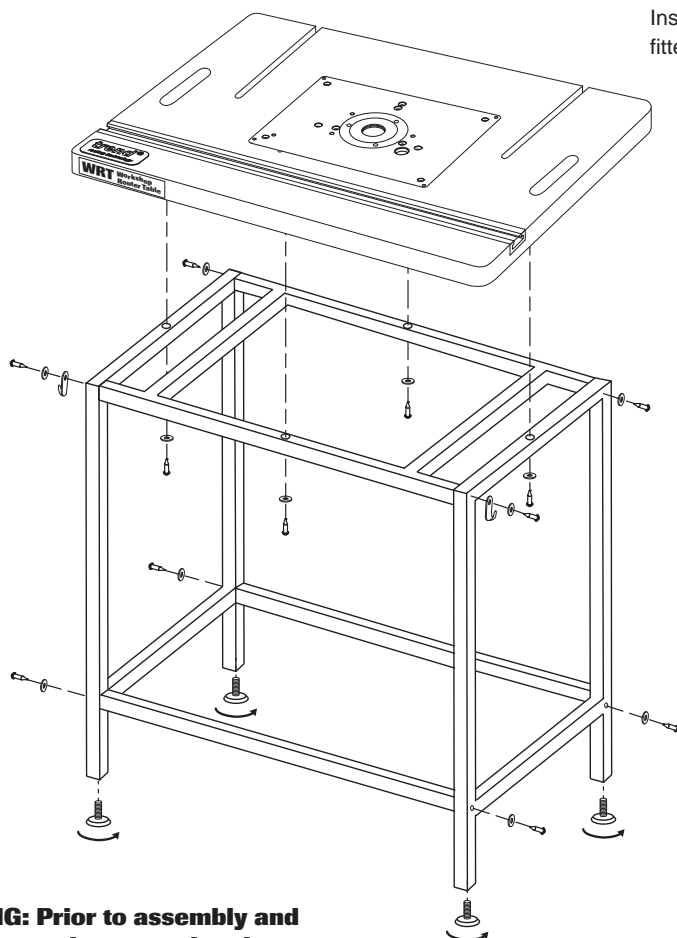

WARNING: Prior to assembly and adjustments always unplug the router table.

Leg Frame Assembly

(underside view)

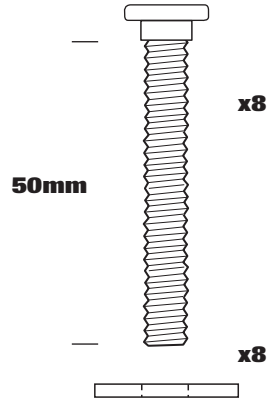
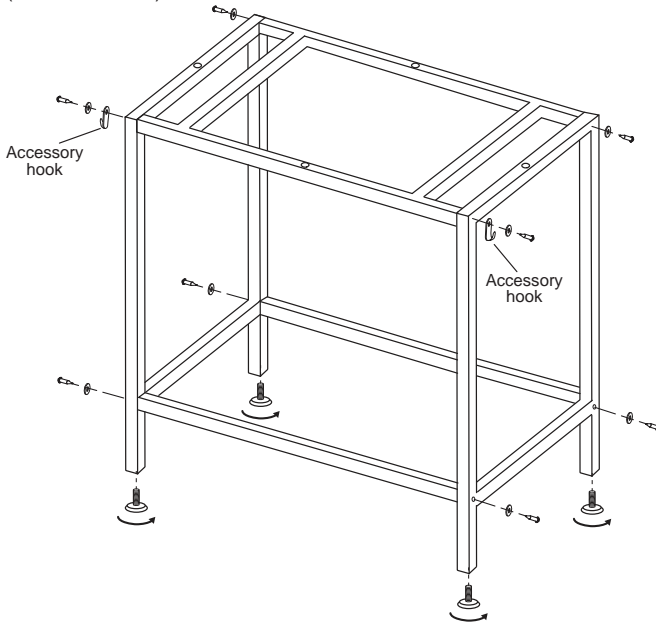

Bench Top Assembly

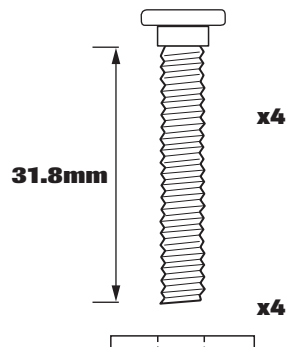
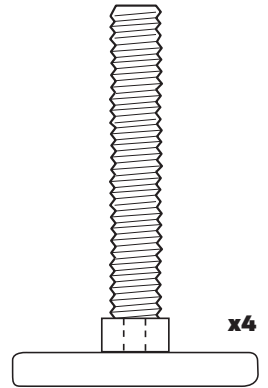
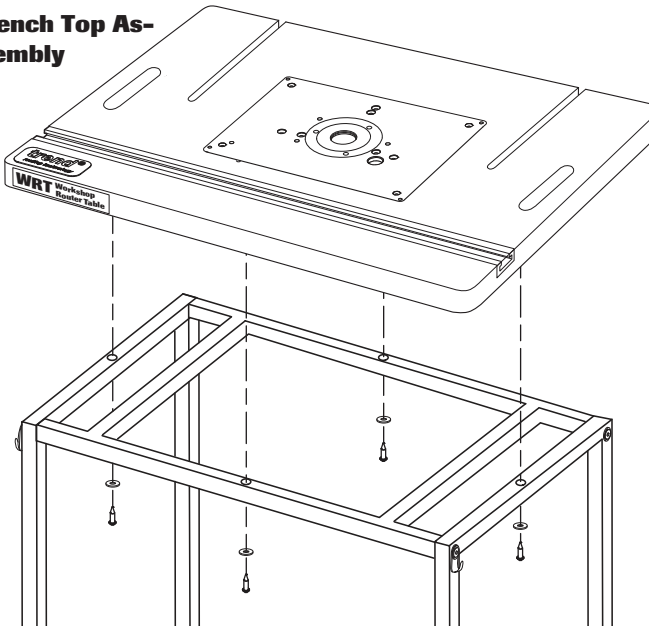

Router Compatibility

The insert plate is drilled to suit routers with TBC hole configuration. The following routers use the screws (B) supplied.

Make	Router Model	Screw x Qty
TREND	T3, T4, T5	B X 2
TREND	T9, T10, T11	B X 3
CMT	CMT1E	B X 3
DEWALT	DW613, 614, 615	B X 2
DEWALT	DW624, 625E	B X 3
ELU	MOF96(E) MK2.	B X 2
ELU	MOF131, 177(E) Mk2	B X 3
PERLES	OF808(E) >1999	B X 2



B
M6x15mm

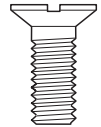

NOTICE: Do not mount any power tools not specified on this list.

For users who choose to fit other makes and models of router, the router base plate and/or insert plate will need to be re-drilled by the user.

Where possible it is advisable to use the existing countersunk holes for M6 machine screws in the insert plate and drill corresponding holes in the router base plate. The router is then fitted using the M6 machine screws, washers and nuts (C or D).

For some machines M5 screws machine screws (A) can be used to fit into the M5 holes in the router base.

The fixing pack supplied with the table includes the following machine screws.

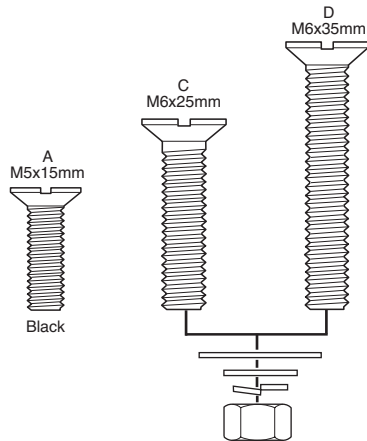

NOTICE: The M6x15mm screws are packed in the backfence fixings bag.

Countersink Hole Size

Screw size	Countersink diameter	Hole diameter
M6	13mm	6mm
M5	10mm	5mm

Mounting Router to Insert Plate

Invert and stand your router onto a suitable surface. Remove insert plate from table and place it facing upwards onto the base of your router. Screws are supplied for TBC routers, see chart on previous page. Use Phillips[®] No.2 screwdriver.

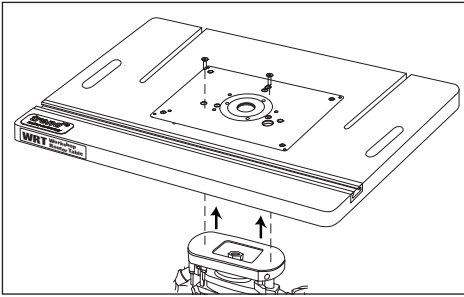

Re-drilling Router Base Only

- Invert and stand your router onto a suitable surface.
- Remove insert plate from table and place it facing upwards onto the base of your router.
- Adjust position of the insert plate to centralise.
- Ensure that the holes you are about to drill in the base (using the TBC holes in the insert plate) do not interfere with any of the features on the router or any webbings in the casting of the router base. A slight turning of the router may be required to miss such obstructions.
- Mark the centre of the holes onto the base.
- Remove insert plate and mark the centre of the holes with a centre punch.
- Drill a hole at these points with a 6mm diameter drill bit.
- Clean up edges of holes if required.

Re-drilling Insert Plate Only

- Remove insert plate from table.
- Remove the plastic base of the router. Alternatively a photocopy or an outline of the base can be made of the plastic base instead.
- Align the centre of the insert plate to the router base and secure them together.
- Using a centre punch, mark the centres of holes.
- Drill the required hole size with a suitable metal cutting drill bit. Best results will be obtained if your power drill is mounted in a drill stand.
- Countersink the hole with a countersink bit to a depth so the heads of the screws are slightly below the top surface. Clean off any burrs created.

Re-drilling both Insert Plate and Router Base

- Invert the router and lay the insert plate onto the upturned base.
- Clamp the insert plate and router base together with two cramps.
- Ensuring that the drill bit will not foul any webbing or fixtures on the router base, drill with a 6mm diameter metal cutting drill bit into the insert plate and through the router base two holes.
- Unclamp the router base and insert plate.
- Countersink the insert plate holes with a countersink bit to a depth so the screw heads are slightly below the top surface. Clean off any burrs created on both the insert plate and router base.

User Made Accessory Workboard Mounting



The table has two holes in the mitre fence extension to accept fixings for a user made accessory workboard. The workboard can then be used to mount other routing jigs, so using the WRT as a workbench.

Boards can be secured using M8 bolts and M8 nuts (not included).

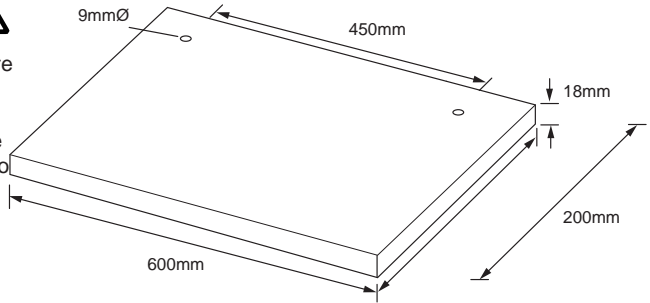

Mounting No Volt Release Switch



The switch can be positioned at the front of the table or on the right hand side.

Fit brackets to underside of table top first using the self tapping screws and a Phillips[®] No.2 screwdriver. Then mount switch to brackets, fit the left hand bolt assembly first.

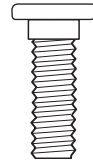
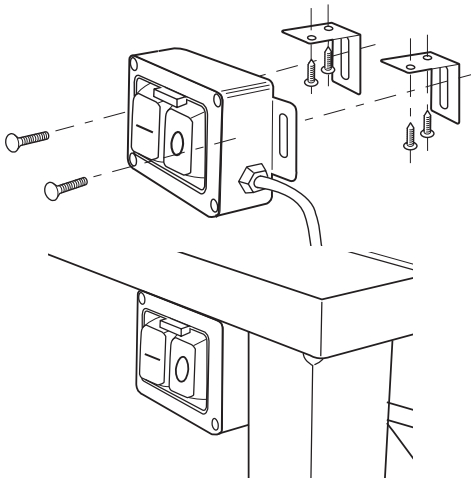

x2

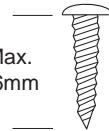

Max. 16mm

x4

Use Phillips[®] No.2 screwdriver.



CAUTION: Ensure workbench is stable and secure.

Levelling the Insert Plate

The insert plate can be levelled to the table top by adjusting the seven set screws with the hex key.

- To adjust, first loosen the four insert plate fixing screws.
- Rotate the seven set screws until insert plate is level to table top.
- Once set, tighten the insert plate fixing screws.
- Check plate for level and adjust as necessary.

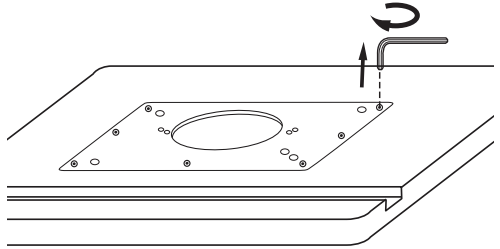

Fitting Insert Rings



WARNING: Always ensure insert rings are a tight fit in the insert plate. Replace damaged or loose rings immediately.

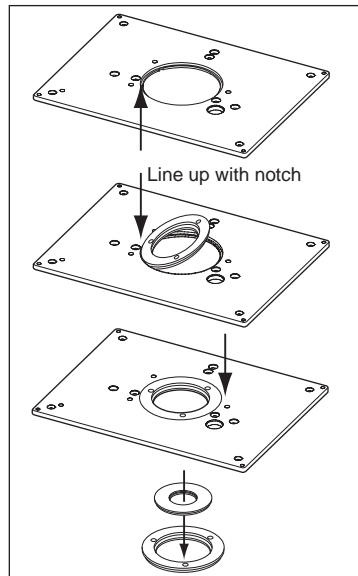
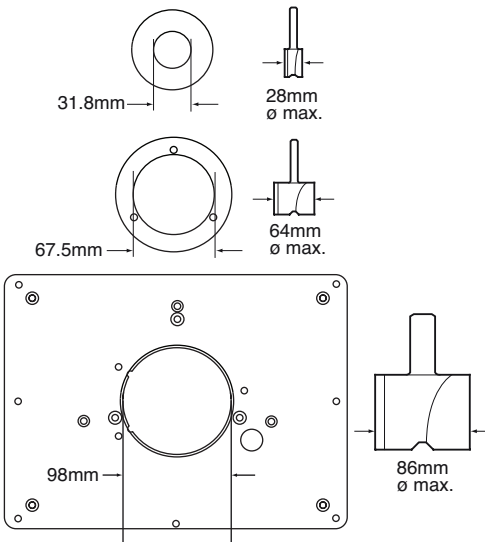
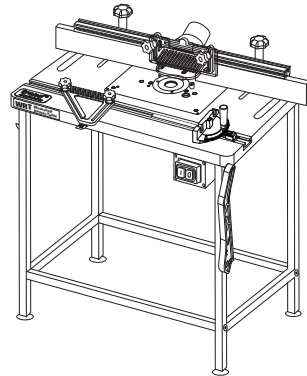

Back Fence Assembly

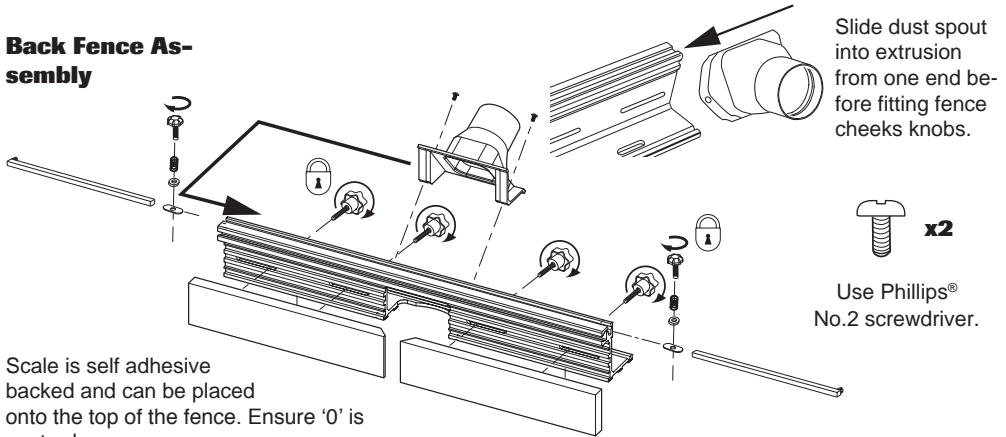

Scale is self adhesive backed and can be placed onto the top of the fence. Ensure '0' is centred.

Scale can be trimmed to the length of the back fence.

Fitting Back Fence

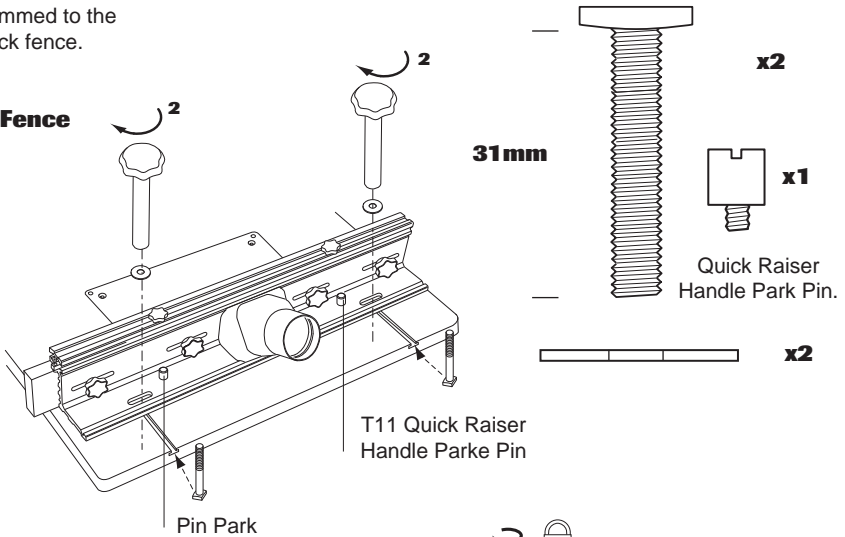

Assembling Mitre Fence

Preset mitre fence angles can be zeroed by loosening the lock nuts on the underside of the protractor using an 8mm A/F spanner, and adjusting the screws using a Phillips® No.2 screwdriver. Once set tighten the nuts with an 8mm A/F spanner.

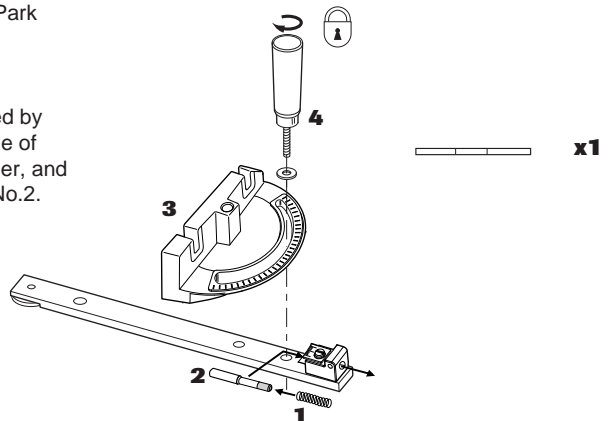

Fitting Top Guard & Top Pressure

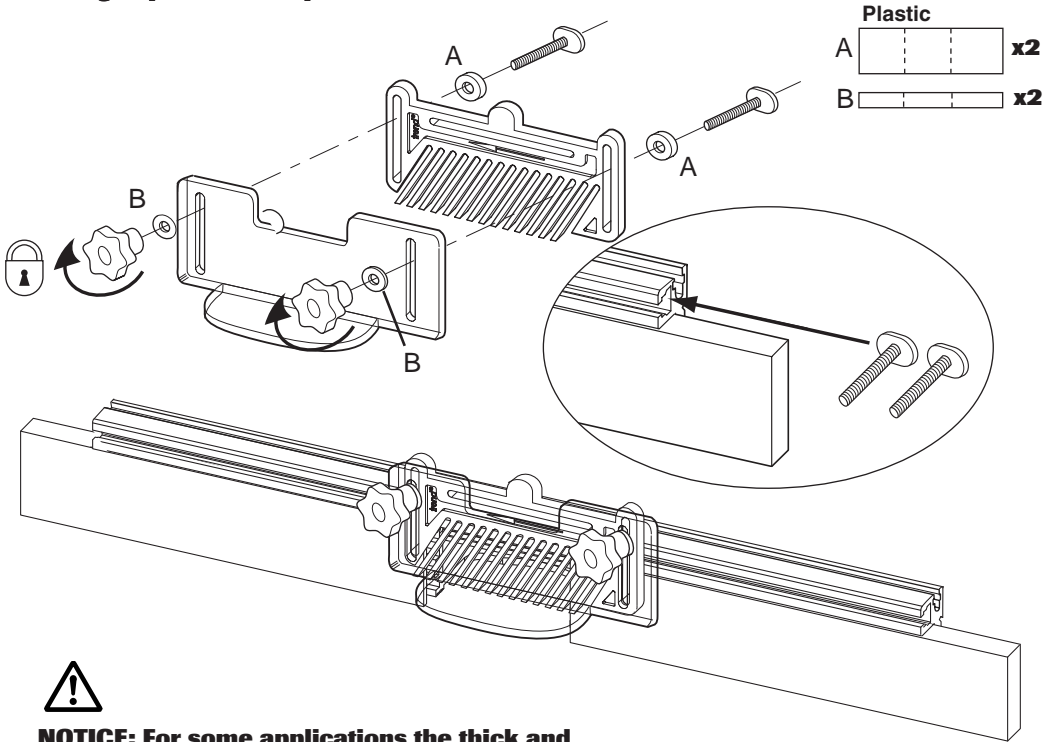

NOTICE: For some applications the thick and thin washer can be swapped over. For example, when profile scribing using a pushblock.

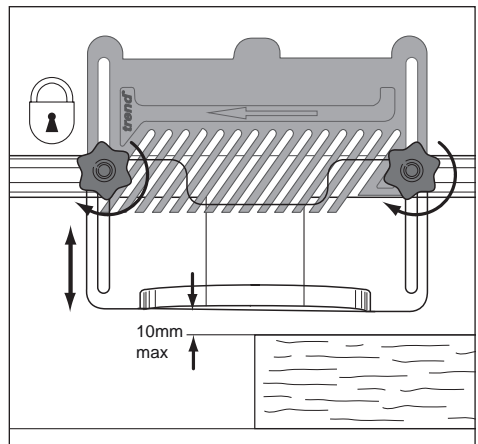
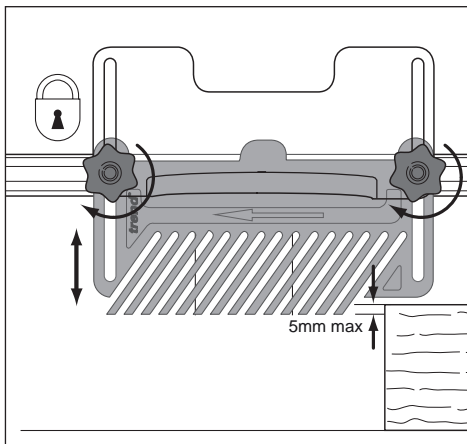

Fitting Side Pressure

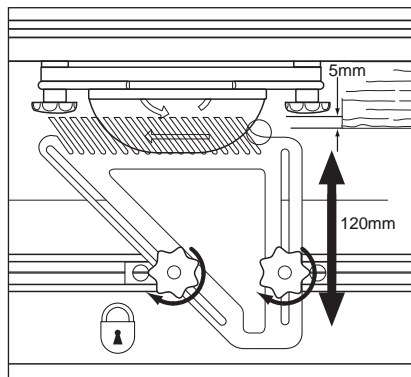
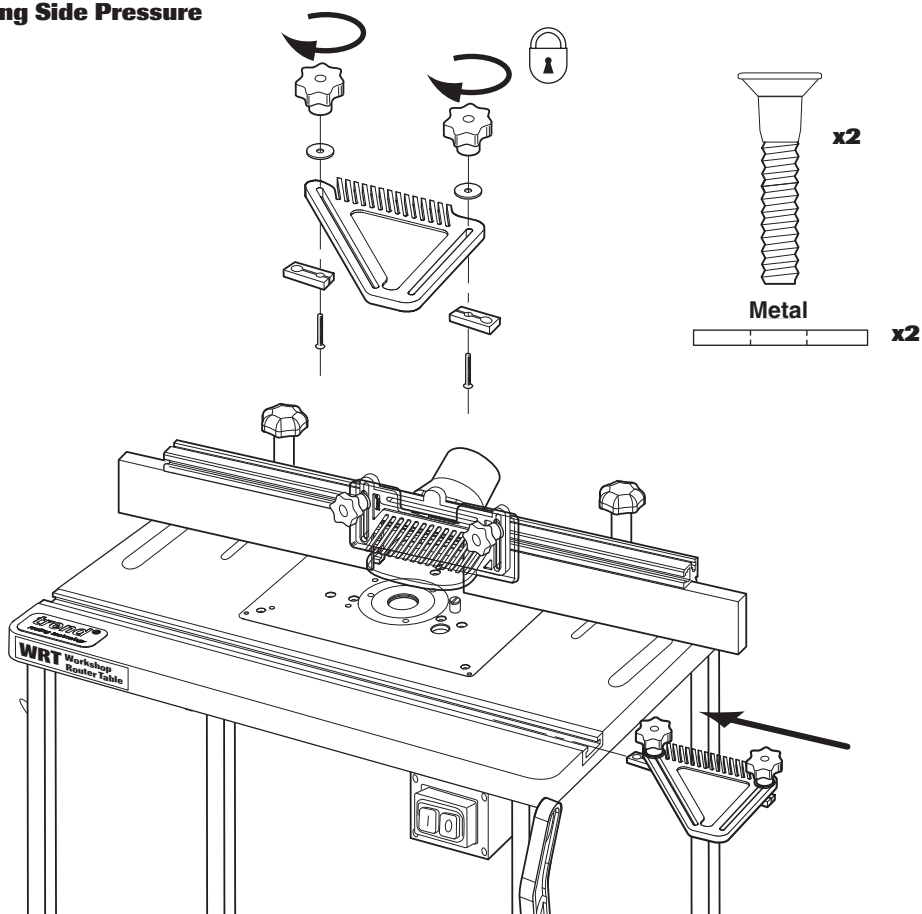

Fitting Mitre Fence

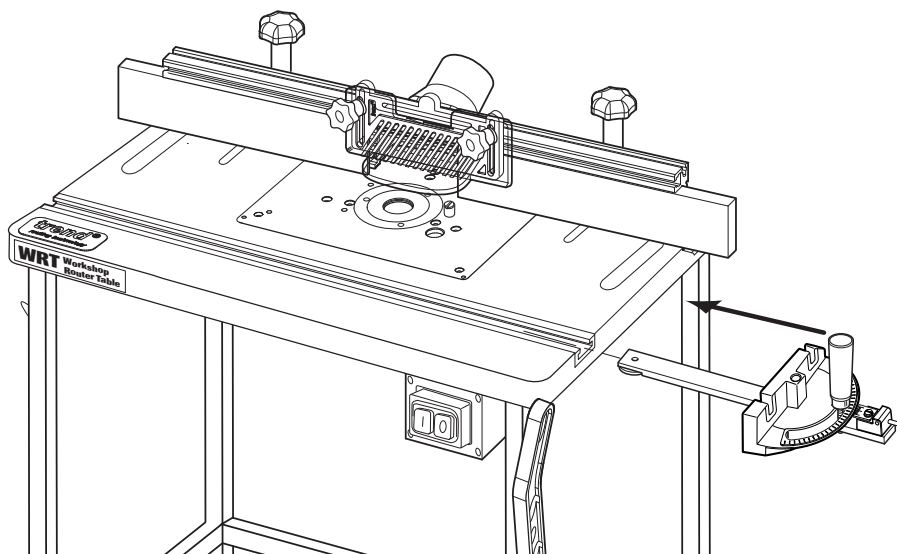

Pushstick Park

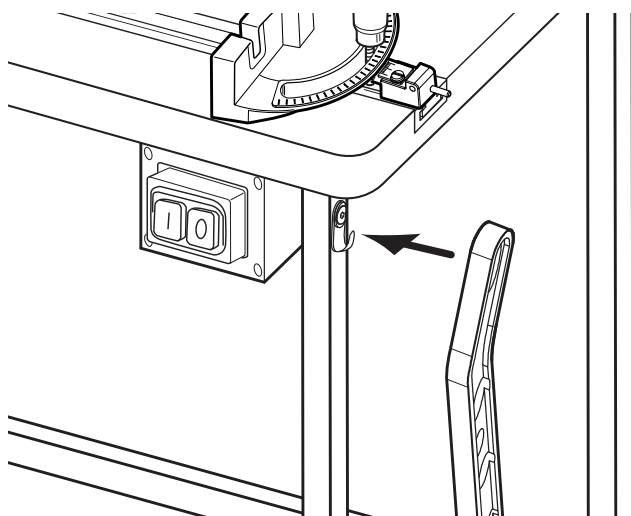

There is a second hook to the left hand side for storing other accessories.

Fitting Cable Management Clips

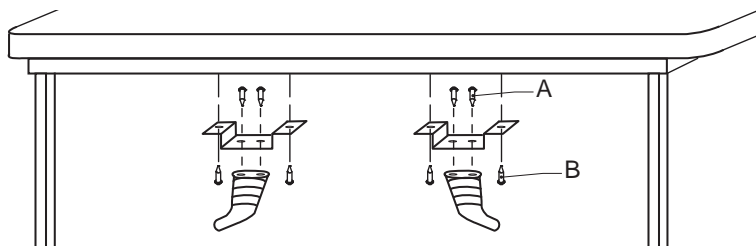

Rear of table.

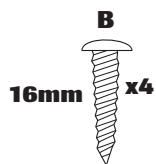
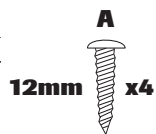

Use Phillips[®]
No.2 screwdriver.

Fitting Dust Extraction Hose
Accessory Ref. CRT/4
(not included)

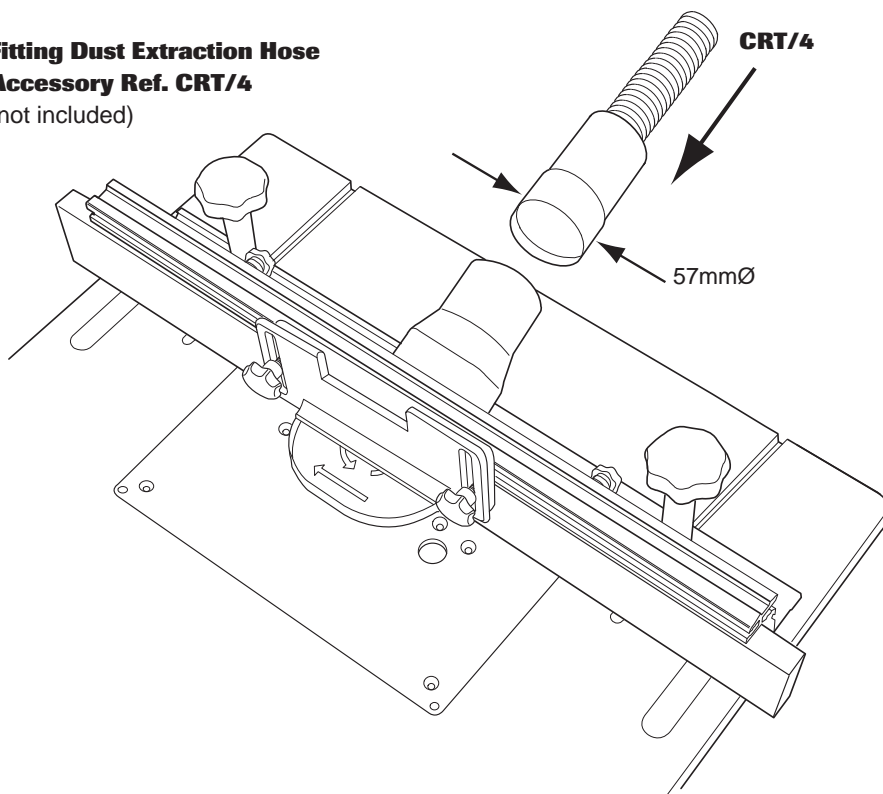

OPERATION



No-Volt Release Switch



- Plug machine into socket.
- Put plug of switch into mains supply.
- Switch on router.
- Press green button to switch on. To switch off press red button.

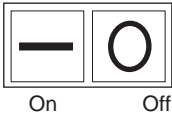

On

Off

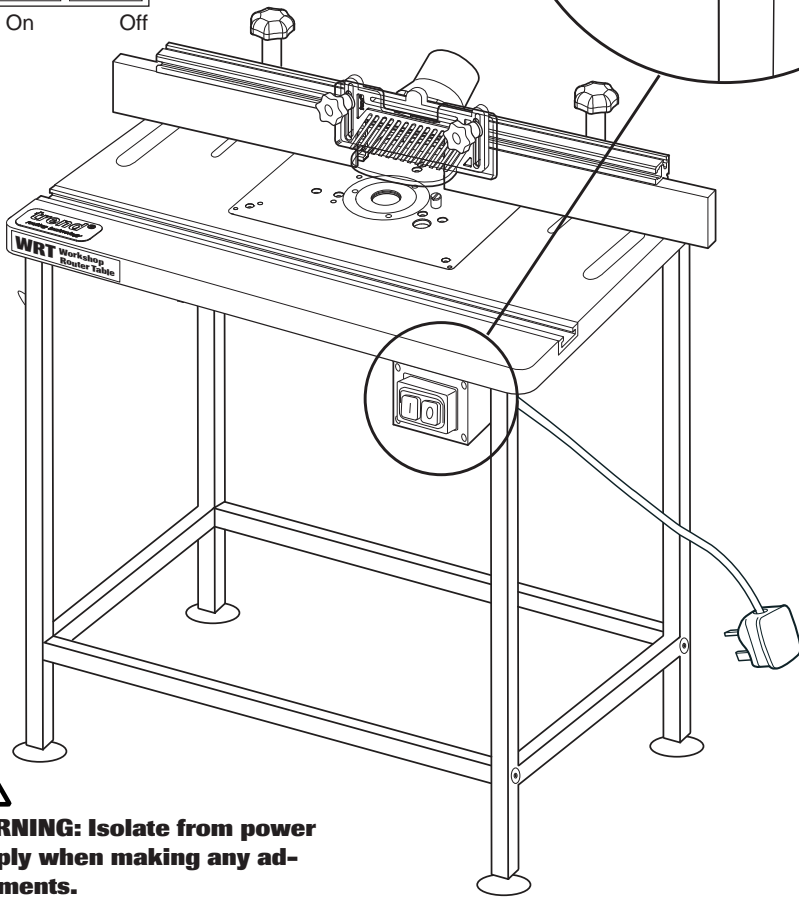
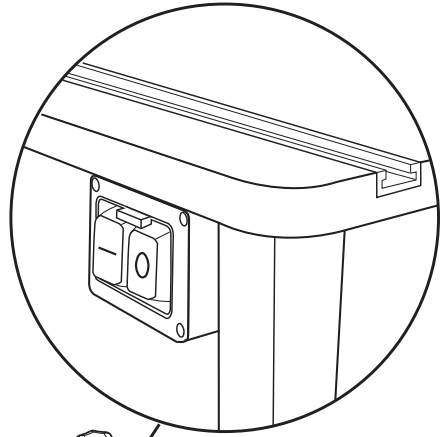

WARNING: Isolate from power supply when making any adjustments.

Back Fence Adjustment 

- Adjust back fence position by loosening the two knobs (A) and pushing the fence forwards or backwards.
- Lock fence position by tightening the two knobs (A).

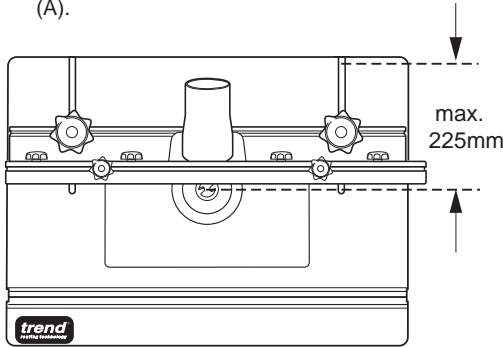

- To adjust fence cheeks loosen four back knobs (B). Slide cheeks in and out to suit cutter. Leave gap of 3mm between cheek and cutter.
- Lock cheeks by tightening four knobs (B).

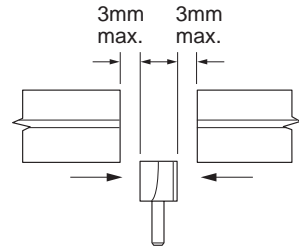
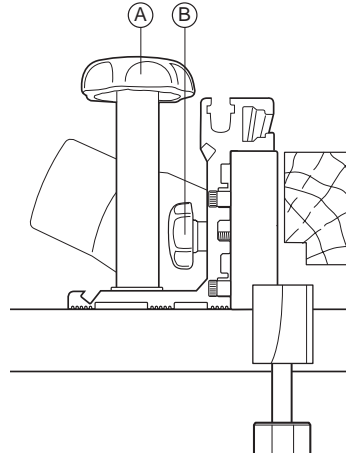

Pushstick Operation 

The pushstick has been designed for use with a router table, and should always be used when making any cut less than 300mm in length or, when feeding the last 300mm of a longer cut. The birds mouth is 90° and should be angled at between 20° to 30° to the workpiece to suit the height of the machinist.

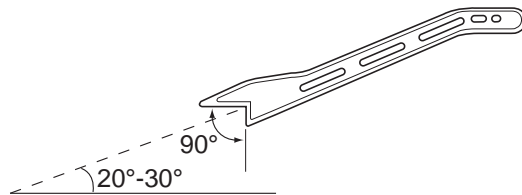

CAUTION: Do not use the pushstick as a lever or for uses other than those envisaged.



CAUTION: Compliance with the safety requirements of the regulations in force is nullified by any modification or tampering with the pushstick.

Edge Moulding and Grooving 

- Isolate from power source.
- Fit cutter.
- Set back fence position.
- Set top and side pressures.
- Fit guard.
- Check all knobs are tight.
- Plug into power supply.
- Switch on.
- Feed right to left.
- Switch off.

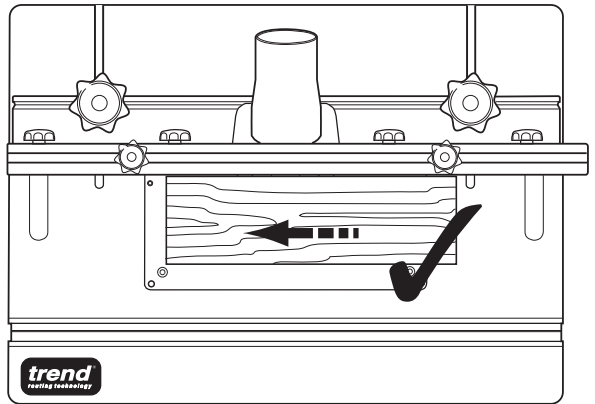
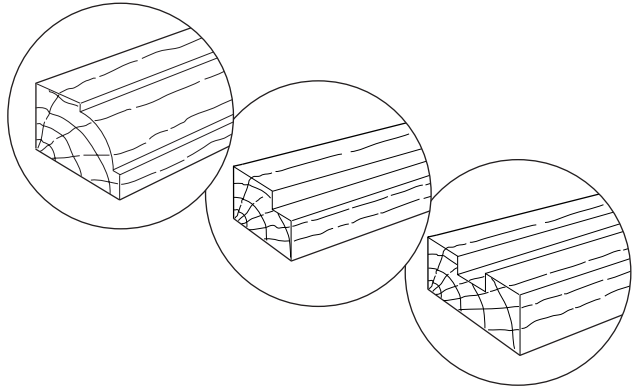

Feed Direction 

- Always work with constant, medium rate. Feeding too slow will result in burn marks and excessive heat build up of the cutter.
- Good results will be obtained by removing small amounts of material in several passes.
- Always feed work in the opposite direction to the direction of rotation of the router cutter.

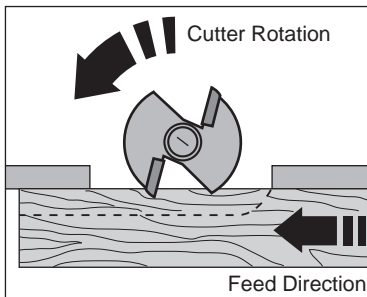
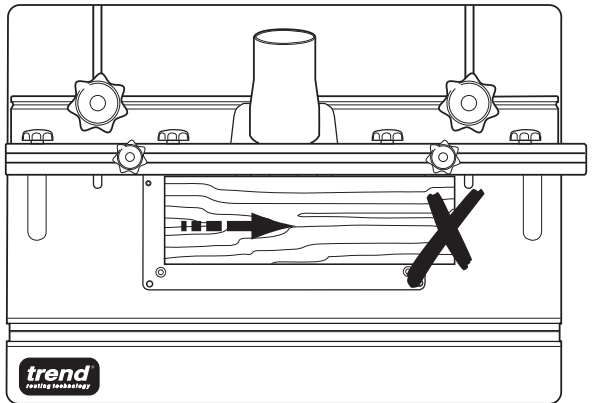

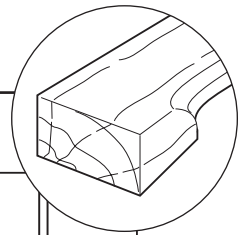

Stopped Moulding 

- Isolate from power supply.
- Fit cutter.
- Set back fence position.
Fit some stops to back fence using cramps or use accessory limit stop Ref.WRT/2 (1 off).
- Fit guard.
- Check all knobs are tight
- Plug into power supply.
- Switch on.
- Drop material against infeed stop A and pivot into cutter.
- Feed right to left, until reaching outfeed limit stop B.
- Pivot at outfeed stop.
- Switch off.

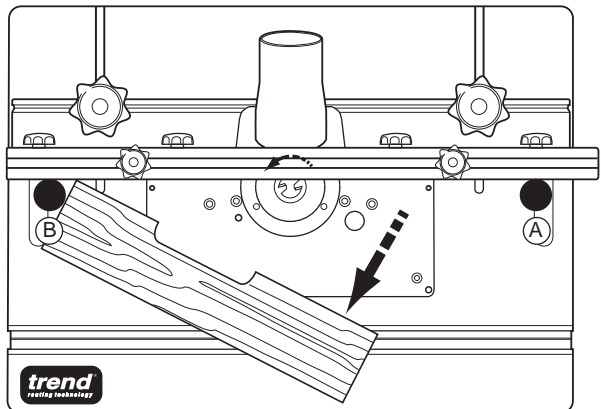
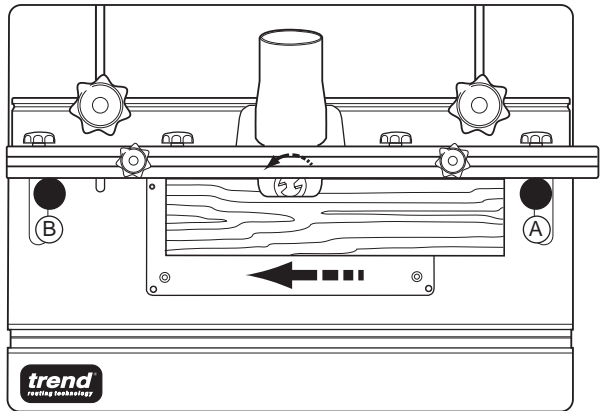
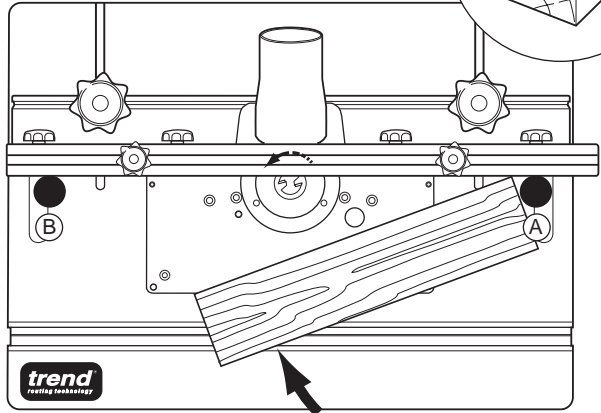

Mitre Fence



- Isolate from power supply.
- Fit cutter.
- Adjust angle of mitre fence by loosening knob and turning protractor head to line up angle required with arrow.
- Place component onto mitre fence.
- Plug into power supply.
- Feed right to left holding component securely.
- Switch off.

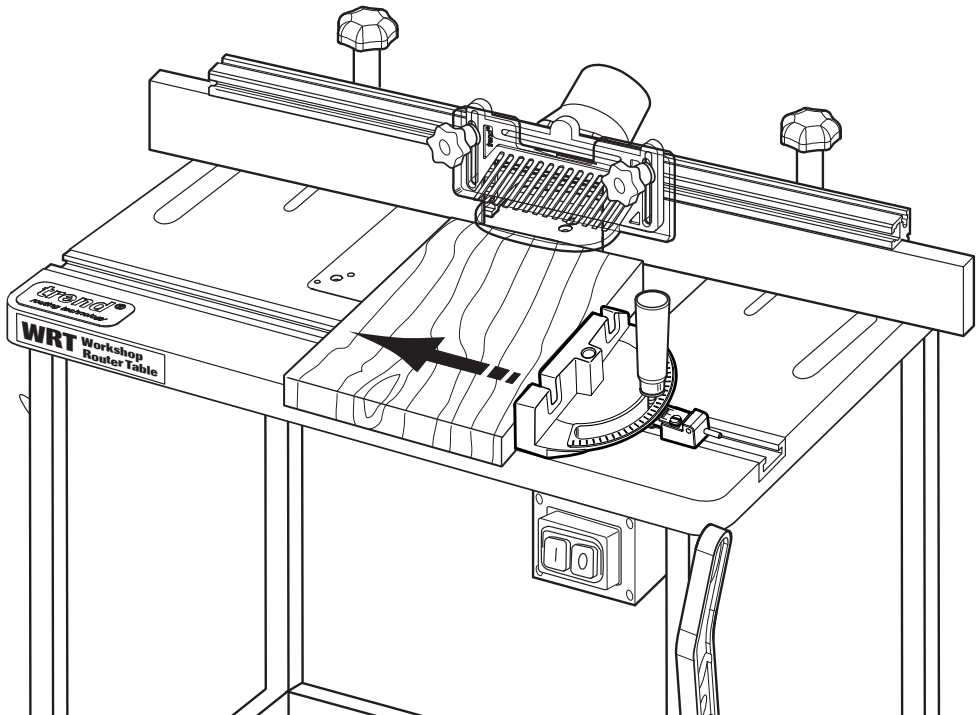

NOTICE: The mitre fence has fixing holes to allow a splch block to be secured using screws (not supplied).

Lead-on Pin

- Isolate from power supply.
- Fit lead-on pin into threaded hole using a slotted screwdriver.
- Move back fence back.
- Fit self guided cutter.
- Fit top guard.
- Plug into power supply.
- Support component onto the lead-on pin and swing into cutter and contact bearing guide.
- Mould component.
- Switch off.

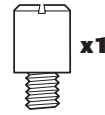
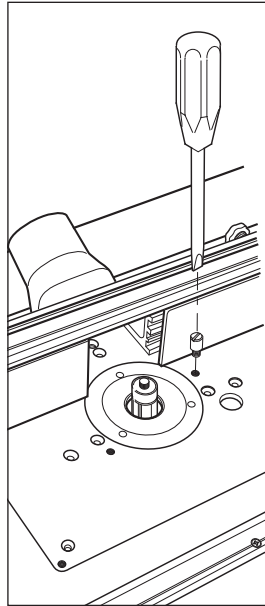

WARNING: Guard removed for clarity. Ensure guard is fitted when using self guided cutters.

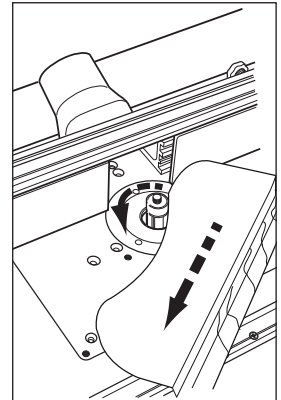
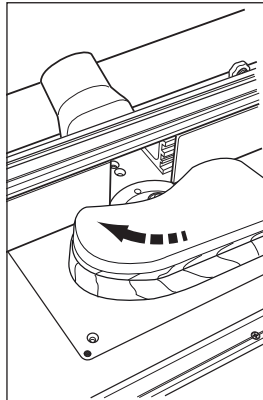
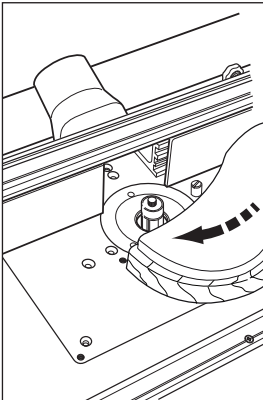

NOTICE: The lead-in pin can be stored in the pin park hole in the back fence when not in use.

Edge Planing 

The router table fence features fully independent fence cheeks which allow the fence to double as a vertical planer for a 1.4mm or 2.4mm offset. To set up for edge planing, remove the two jointing rods which are stored in the top slot of the fence, loosen the outfeed fence cheek and place the rods into the shallow recesses behind the outfeed fence.

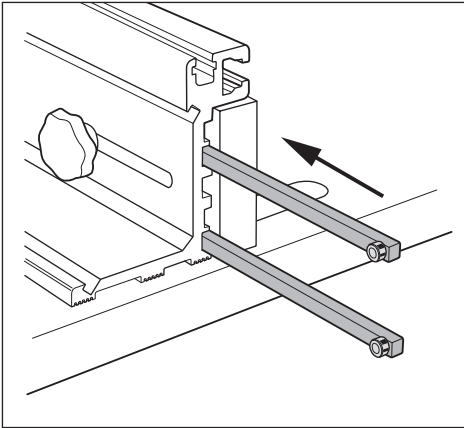

The rods can be parked in the T-slots in the top of the back fence. The rods are held by tightening the knobs.

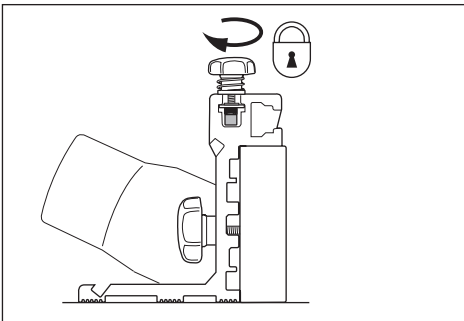

To position the fence at the 1.4mm setting, slide the rods into the deeper recesses, as shown below and tighten the fence cheeks locking knobs.

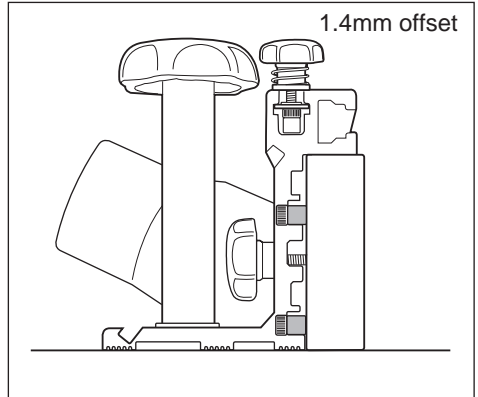

the rods into the shallower recesses, as shown below and tighten the fence cheeks locking knobs.

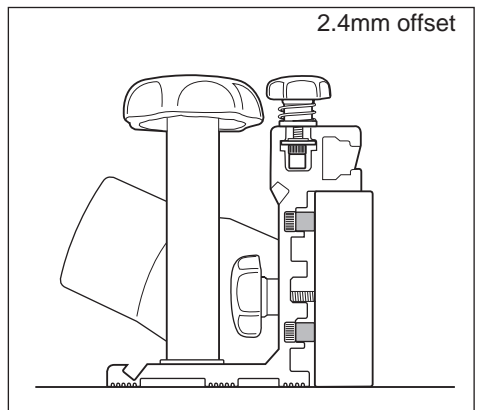

After use of the table, keep assembled and store properly.

ACCESSORIES

Please use only Trend original accessories.

Hose and Connector

Ref. CRT/4

The back fence is provided with an extraction point for connection to suitable vacuum extractors. The internal hole diameter is 57mm (2-1/4").

- Only a vacuum extractor unit recommended for use in the workshop should be used.
- A suitable adaptor and extraction hose can be purchased as optional accessories.

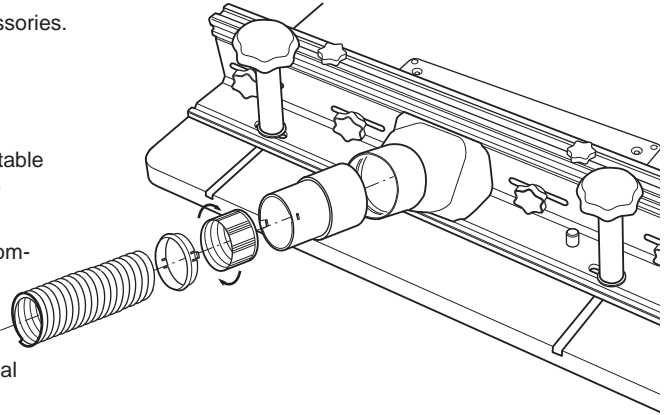

The accessory hose Ref. CRT/4 has an outside diameter of 39mm and inside diameter of 32mm. It is fitted with the hose adaptor which is a three piece design that allows the hose to swivel freely.

- Assemble the hose adaptor onto the end of the hose as shown and insert into back fence.
- Fit the other end of the extraction hose to your dust extractor.

CRT/4

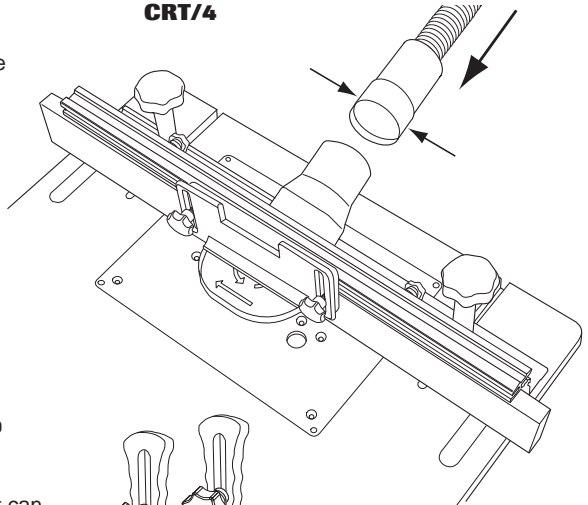

Ref. CRT/4 Hose 39mm OD x
 32mm ID x 3m.

Single Pressures and Limit Stop

Ref. WRT/1, WRT/2

Ref. WRT/1 Pair of single pressures that can fit to back fence face extrusion for machining longer lengths of timber.

Ref. WRT/2 Limit stop with height adjustment fits to back fence top extrusion.

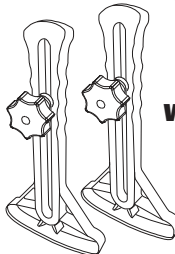

WRT/1

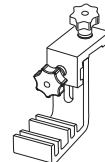

WRT/2

Castors

Ref. WRT/3

Ref. WRT/3 Castors (4 pack) with foot operated lock. Raises router table height by 35mm. Replaces standard feet.

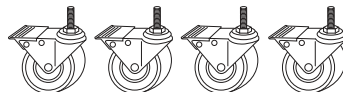

WRT/3

MAINTENANCE



The router table has been designed to operate over a long period of time with a minimum of maintenance. Continual satisfactory operation depends upon proper tool care and regular cleaning.

- Replace the cutter insert when worn out.

Cleaning

- Keep the grooves clear of sawdust. Regularly clean the table with a soft cloth.
- The pushstick is made of thermoplastic material which is resistant to solvents, oils, greases and water. Do not use concentrated acids or alkalis for cleaning.

Lubrication

- Your router table requires no additional lubrication. Do not use PTFE spray on the plastic components of the table.

Storage

- When not in use the table should be stored safely. It is advisable to cover the table.
- The pushstick is provided with holes to store easily on the table.

ENVIRONMENTAL PROTECTION



Recycle raw materials instead of disposing as waste.

Accessories and packaging should be sorted for environmental-friendly recycling.



Separate collection. This product must not be disposed of with normal household waste.

Household User

Local regulations may provide for separate collection of electrical products from the household, at municipal waste sites or by retailer when you purchase a new product.

Please call Trend Customer Services for advice as to how to dispose of unwanted Trend electrical products in an environmentally safe way or visit www.trend-uk.com

Business User

Please call Trend Customer Services for disposal of unwanted Trend electrical products.

GUARANTEE

The unit carries a manufacturers guarantee in accordance with the conditions on the enclosed guarantee card.

For the location of your nearest Trend Service Agent, please call Trend Customer Services or see Stockist Locator at www.trend-uk.com

Please use only Trend original spare parts.

WRT - SPARE PARTS LIST			v1.0 03/2017
No.	Qty.	Desc.	Ref.
1	1	Table Top	WP-WRT/01
2	1	Insert Plate	WP-WRT/02
3	1	Back Fence	WP-WRT/03
4	2	Fence Cheek	WP-WRT/04
5	1	Top Frame	WP-WRT/05
6	2	Crossbar	WP-WRT/06
7	2	Legs	WP-WRT/07
8	2	Edge Planing Rod	WP-WRT/08
9	2	T-Nut for Edge Planing Knob	WP-WRT/09
10	1	No Volt Release Switch 240V UK Plug	NVRS/2/240V
	1	No Volt Release Switch 230V EURO Plug	NVRS/2/230V/E
11	2	Spring for Edge Planing Knob	WP-CRTMK3/11
12	2	Knob for Edge Planing Assembly	WP-CRTMK3/12
13	4	Knob UNC 1/4 - 20 x 3/4" Male for Fence Cheek	WP-CRTMK3/13
14	2	Washer 8mm x 23mm x 2mm for Back Fence Knob	WP-CRTMK3/14
15	2	Back Fence Knob UNC 5/16 Female	WP-CRTMK3/15
16	1	Dust Spout	WP-CRTMK3/16
17	2	Machine Screw M4 x 8mm Pozi for Dust Spout	WP-CRTMK3/17
18	2	T Bolt UNC 1/4 - 20 x 1-3/4" for Top Guard	WP-CRTMK3/18
19	2	Washer for T Bolt	WP-CRTMK3/19
20	1	Top Pressure	WP-CRTMK3/20
21	1	Top Guard	WP-CRTMK3/21
22	2	Washer Plastic for Top Guard	WP-CRTMK3/22
23	2	Knob UNC 1/4 - 20 Female for Plastic Guard	WP-CRTMK3/23
24	2	Knob for Side Pressure	WP-CRTMK3/24
25	2	Washer 8mm x 23mm x 2mm for Side Pressure Bolt	WP-CRTMK3/25
26	1	Side Pressure	WP-CRTMK3/26
27	2	Hook for Pushstick WRT	WP-WRT/27
28	2	Plate for Side Pressure Bolt	WP-CRTMK3/28
29	2	Machine Screw Csk 1/4" x 1-9/16" Phillips	WP-CRTMK3/29
30	7	Set Screw M6 x 6mm for Fixing Plate	WP-CRTMK3/30
31	3	Machine Screw Csk M6 x 15mm Phillips	WP-CRTMK3/31
32	1	Insert Ring 31.8mm ID	WP-CRTMK3/32
33	1	Insert Ring 67.5mm ID	WP-CRTMK3/33
34	4	Machine Screw Csk M5 x 16mm Skt	WP-CRTMK3/34
35	1	Lead-on Pin	WP-CRTMK3/35
36	4	Magnet 8mm x 5mm	WP-CRTMK3/36
37	1	Self Tapping Screw for Mitre Fence Extrusion	WP-CRTMK3/37
38	1	Mitre Fence Extrusion	WP-WRT/38
39	2	T Bolt UNC 1/4 x 1-1/4" x 2" Male for Back Fence	WP-WRT/39
40	2	Switch Bracket	WP-CRTMK3/40

WRT - SPARE PARTS LIST			v1.0 03/2017
No.	Qty.	Desc.	Ref.
41	2	Washer for Edge Planing Assembly	WP-CRTMK3/41
42	8	Self Tapping Screw Pan 4mm x 16mm Phillips	WP-CRTMK3/42
43	8	Machine Screw Carriage UNC 1/4 X 2" Frame Skt	WP-WRT/43
44	12	Washer for Leg Assembly	WP-WRT/44
45	4	Machine Screw UNC 1/4 x 1-1/4" Skt for Frame to Table Top	WP-WRT/45
46	4	Nut Hex for Foot Assembly	WP-WRT/46
47	4	Foot	WP-WRT/47
48	4	Cable Management Clip Bracket	WP-WRT/48
49	-	-	-
50	2	Scale Label	WP-CRTMK3/50
51	1	T11 Quick Raiser Handle Park Pin	WP-WRT/51
52	1	Mitre Fence Knob	WP-CRTMK3/52
53	1	Washer for Mitre Fence	WP-CRTMK3/53
54	1	Mitre Fence Body	WP-CRTMK3/54
55	1	Mitre Fence Rail and Index Head	WP-CRTMK3/55
56	2	Cable Management Clip	WP-CRTMK3/56
57	4	Self Tapping Screw Pan 4mm x 12mm Phillips	WP-CRTMK3/57
58	1	Back Fence Scale	WP-WRT/58
59	2	Machine Screw Pan M6 x 16mm Phillips	WP-CRTMK3/59
60	1	Mitre Fence Location Pin	WP-CRTMK3/60
61	1	Mitre Fence Location Pin Spring	WP-CRTMK3/61
62	2	Table Top Back Fence Extrusion	WP-WRT/62
63	1	Pushstick	PUSHSTICK/1
64	1	Hex Key 3mm A/F	WP-AP/03
65	1	Hex Key 4mm A/F	WP-AP/04
66	1	Router Screw Fixing Pack Csk	FIX/KIT/2
67	1	Manual	MANU/WRT

WRT - SPARE PARTS DIAGRAM

v1.0 03/2017

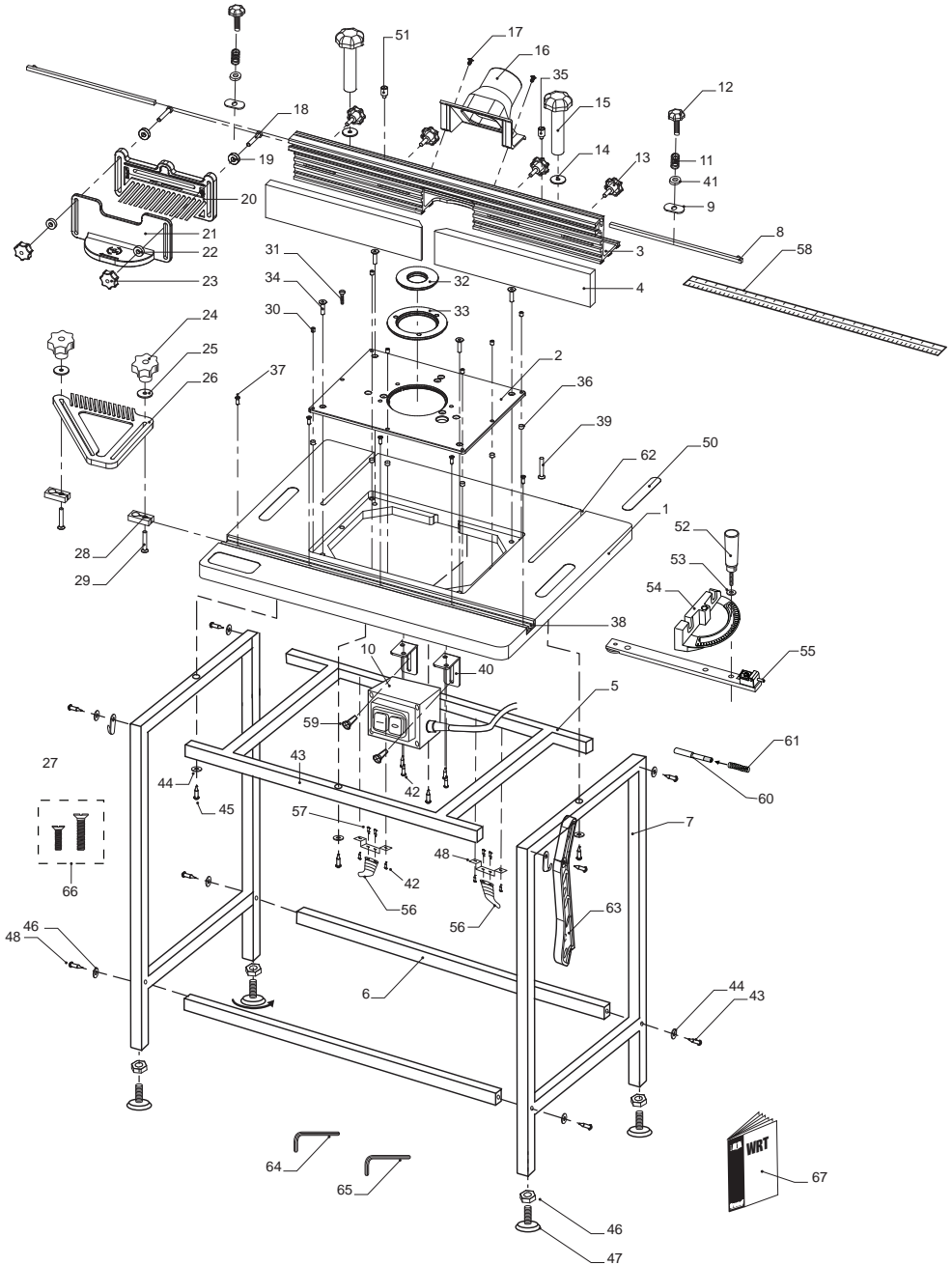

MANUWRT v2.0



RECYCLABLE

Trend Machinery & Cutting Tools Ltd.

Odhams Trading Estate St Albans Road
Watford WD24 7TR England

Tel: 0044(0)1923 249911
technical@trendm.co.uk

www.trend-uk.com

© Copyright Trend 2017, 2018. No part of this publication may be reproduced, stored or transmitted in any form without prior permission.

Our policy of continuous improvement means that specifications may change without notice.

Trend Machinery and Cutting Tools cannot be held liable for any material rendered unusable or any form of consequential loss. E&OE

© All trademarks acknowledged.