

ROUTER TABLE INSERT PLATE

Large rigid table insert plate for incorporation into user made router tables.

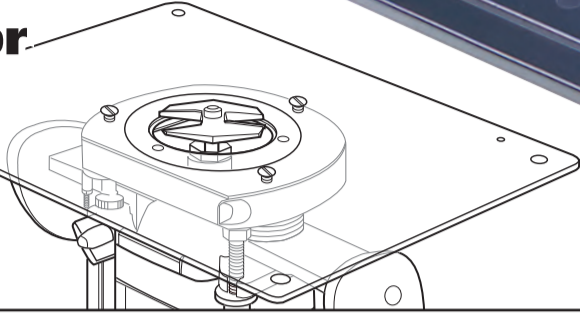

MOUNTING INSTRUCTIONS

Rout out aperture 280mm x 203mm.
Rebate inner top edge 6.35mm deep and 12.7mm wide to accept insert plate.

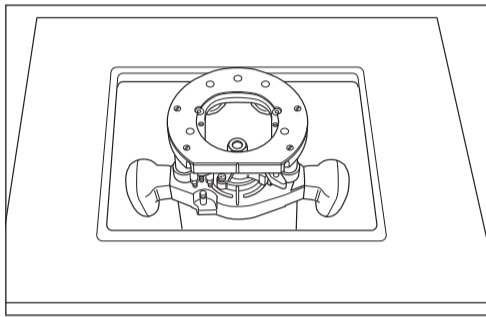

1. When mounting a large router, position it so the handles fit through the opening.

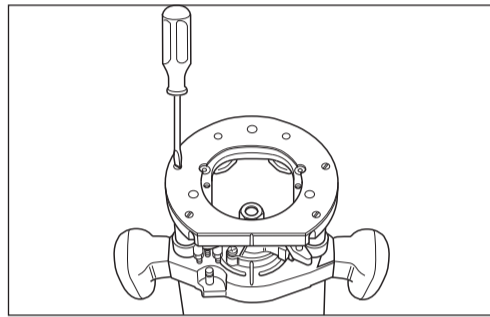

2. Remove router plastic slider base.

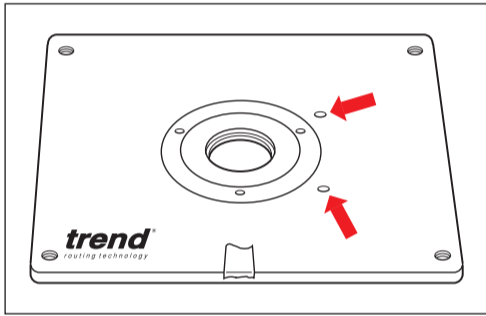

3. The top and front of the Insert Plate is determined by the location of the lead-on pin holes. These holes are to the right of the cutter aperture.

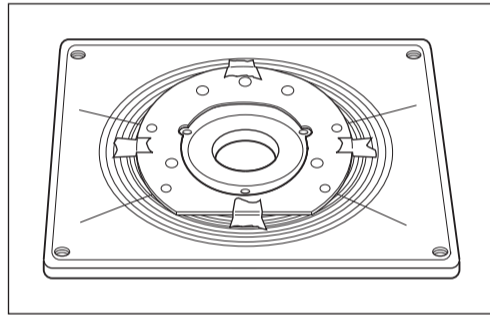

4. Centre your existing base plate slider using the concentric rings, and line up the mounting holes on the radial lines (radial lines work with most routers). Ensure holes in sliding base do not interfere with lead-on pin holes. Use sticky tape to hold the plate in position.

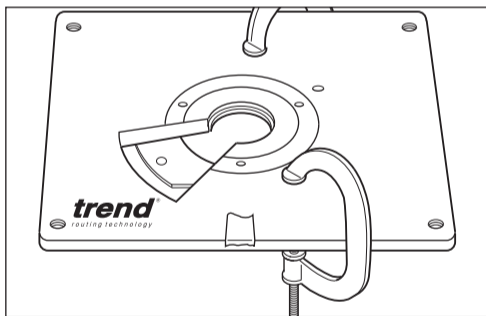

5. Securely clamp plates together using 'G' cramps. Do not use spring clamps because they do not exert enough pressure and the parts may move.

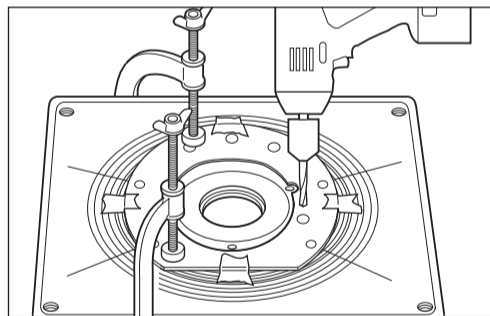

6. Using the correct drill bit diameter, drill through the plastic slider base. Use a drill stand if possible to ensure the holes are accurate.

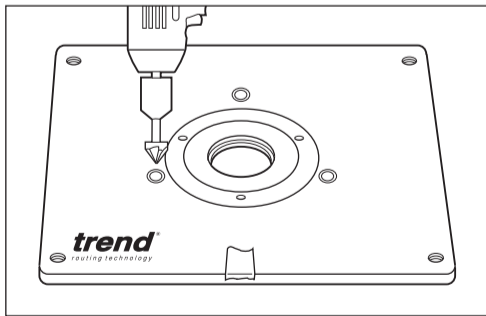

7. Remove clamps, and countersink the holes from the top. Use a drill stand if available.

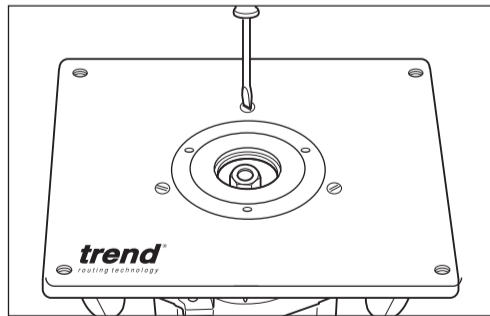

8. Mount the insert plate to the router using suitable screws (not included).

9. Fit corner clips and secure plate to table. The corner clips are designed to clamp into the corner and not to clamp down to the table. Ensure all fixing screws are subflush. Fit router table safety accessories before use.

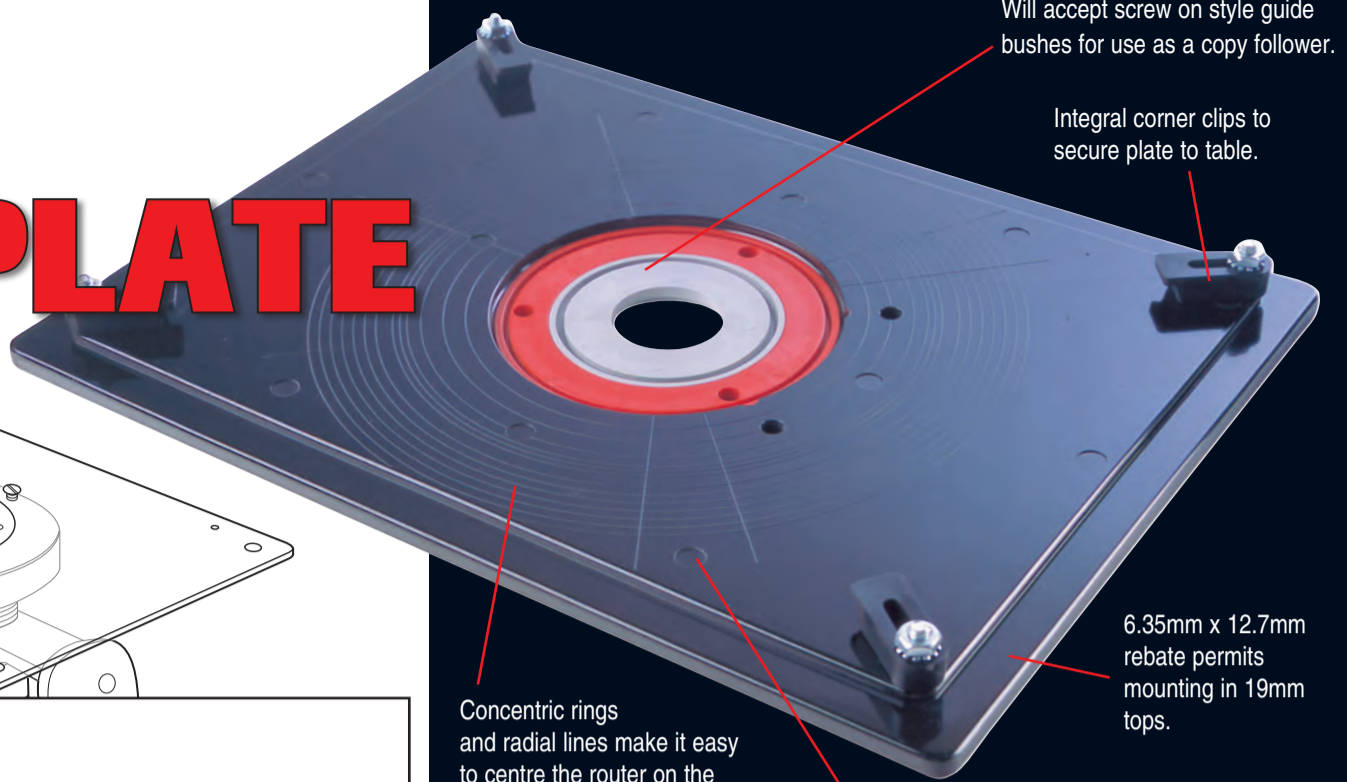

Will accept screw on style guide bushes for use as a copy follower.

Integral corner clips to secure plate to table.

6.35mm x 12.7mm rebate permits mounting in 19mm tops.

Concentric rings and radial lines make it easy to centre the router on the base plate.

Moulded with slight crown (0.8mm) on top for distortion free cuts.

- Rigid 9.5mm thick phenolic plate.
- Supplied with two concentric rings and lead-on pin.
- Can be used with most makes of router.
- Integral corner clips.
- Concentric rings & radial lines on underside for easy centring of router.

Specification

Insert plate size	306mm x 229mm x 9.5mm
Aperture size required	280mm x 203mm
Aperture rebate size required	6.35mm x 12.7mm
Aperture corner radius	6.35mm
Suggested table thickness	19mm
Max. weight of router	8kg
Max. router base dia.	200mm
Router cutter aperture	98mm
Insert ring apertures	68mm/32mm
Cutter dia. max.	94mm/64mm/28mm

Intended Use

The plate is intended to be user drilled to accept a router. Plate is to be recessed into a user made table top to create a router table. It is to be used with a back fence, safety top guard, safety top & side pressures, a no-volt release switch, pushstick and fine height adjuster.

Safety

User must be competent in using woodworking equipment before using our products. Consider working environment before using tools. Ensure working position is comfortable and component is held securely. Please keep children away from tools and work area. All tools have a residual risk so must therefore be handled with caution. Please read all safety instructions supplied with the router before use. Only use router cutters to EN847-1/2 standard.

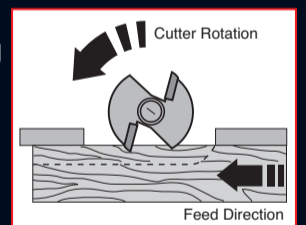

Items Required

Hand tools, clamps, drill, drill & countersink bits, user made table top, router, rebate cutter and router table safety accessories.

Maintenance

Use only Trend original spare parts and accessories. Regularly clean with a soft cloth. No additional lubrication is required. After use keep plate in table top and cover with a dust cover. Product and accessories at the end of life should be sorted for environmentally friendly recycling.

SPARE PARTS:

- Insert 32mm to 68mm
Ref. **WP-RTI/01**
- Insert 68mm to 98mm
Ref. **WP-RTI/02**
- Lead-on Pin
Ref. **WP-RTI/03**
- Corner Clip Fixing Kit
Ref. **WP-RTI/04**

ACCESSORIES:

- Insert Plate Shield
Ref. **RTI/SHIELD**
- Countersink Screw Fixing Pack
Ref. **FIX/KIT/2**
- Pushstick
Ref. **PUSHSTICK/1**

Product Ref.
RTI/PLATE



5 027654 521946 >



Trend Machinery & Cutting Tools Ltd.
Tel: 0044(0)1923 249911
technical@trendm.co.uk
www.trend-uk.com
Manufactured by ROUSSEAU CO.
© 2013 Trend Machinery & Cutting Tools Ltd

PP CRT/PLATE v2.0

trend[®]
routing technology