



HINGE/JIG & H/JIG/A



trend[®]
routing technology



Please read these instructions before use.

Dear Customer

Thank you for purchasing this Trend product, we hope you enjoy many years of creative and productive use.

Please remember to return your guarantee card within 28 days of purchase.

CONTENTS

TECHNICAL DATA _____ 1
SAFETY _____ 2-3
ITEMS ENCLOSED _____ 4
ASSEMBLY & DESCRIPTION OF PARTS ___ 5
 - Setting up the Router _____ 6
 - Fitting the Router Cutter _____ 7
OPERATION
 - Setting the Jig for Hinge Recessing _____ 8-9
 - Routing the Recess in the Door _____ 10-11
 - Routing Hinge Recesses in the Frame ___ 12-13
 - Fitting the Door _____ 14
ACCESSORIES _____ 14
MAINTENANCE _____ 14
ENVIRONMENTAL PROTECTION _____ 14
GUARANTEE _____ 14
SPARE PARTS
 – Spare Parts List _____ 15
 – Spare Parts Diagram _____ 16
QUICK START INSTRUCTIONS _____ 1B

The hinge jig will cut apertures to suit the hinge shown.

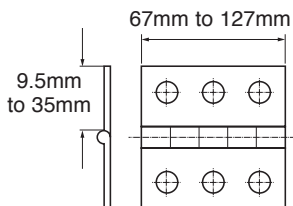

If you require further safety advice, technical information or spare parts, please call Trend Technical Support or visit www.trend-uk.com

TECHNICAL DATA

Guide bush size		16mm
Hinge length	min.	67mm (2 ⁵ / ₈ "")
	max.	127mm (5")
Hinge width	min.	9.5mm (3/8")
	max.	35mm (1 ³ / ₈ "")
Door height	min.	1956mm (6'5")
	max.	2100mm (7")*
Door thickness	min.	16mm (5/8")
	max.	51mm (2")
Fixed stop thickness	max.	25mm
Weight		7.3kg

* For doors over 6' 8" the bottom hinge position can no longer be 9" up from bottom.

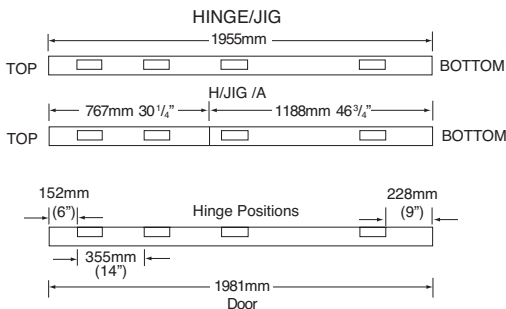

PLEASE NOTE: For doors over 6' 8" the bottom hinge position can no longer be 9" up from the bottom.

The following symbols are used throughout this manual:



Denotes risk of personal injury, loss of life or damage to the tool in case of non-observance of the instructions in this manual.



Refer to the instruction manual of your power tool.

This unit must not be put into service until it has been established that the power tool to be connected to this unit is in compliance with 2006/42/EC (identified by the CE marking on the power tool).

INTENDED USE

This jig allows hinge recesses to be routed in a wooden door or frame with stops up to 25mm thick.

It should be used with a portable plunge router fitted with a suitable guide bush and router cutter fitted.

SAFETY



WARNING:

Observe the safety regulations in the instruction manual of the power tool to be used. Please read the following instructions carefully. Failure to do so could lead to serious injury. When using electric tools, basic safety precautions, including the following should always be followed to reduce the risk of fire, electric shock and personal injury. Also observe any applicable additional safety rules. Read the following safety instructions before attempting to operate this product.

PLEASE KEEP THESE INSTRUCTIONS IN A SAFE PLACE.

The attention of UK users is drawn to The Provision and Use of Work Equipment Regulations 1998, and any subsequent amendments.

Users should also read the HSE/HSC Safe Use of Woodworking Machinery Approved Code of Practice and Guidance Document and any amendments.

Users must be competent with woodworking equipment before using our products.

IMPORTANT NOTE:

Residual Risk. Although the safety instructions and operating manuals for our tools contain extensive instructions on safe working with power tools, every power tool involves a certain residual risk which cannot be completely excluded by safety mechanisms. Power tools must therefore always be operated with caution!

General

1. Disconnect power tool and attachment from power supply when not in use, before servicing, when making adjustments and when changing accessories such as cutters. Ensure switch is in "off" position. Always ensure cutter has stopped rotating.
2. Always mount the power tool, accessory or attachment in conformity with the instructions. Only use attachment and accessories specified in the power tool manual. The tool or attachment should not be modified or used for any application other than that for which it was designed. Do not force tool.
3. Keep children and visitors away. Do not let children or visitors touch the tool, accessory or attachment. Keep children and visitors away from work area. Make the workshop child proof with padlock and master switch.
4. Dress properly. Do not wear loose clothing or jewellery, they can be caught in moving parts. Rubber gloves and non-skid footwear is recommended when working

outdoors. Wear protective hair covering to contain long hair.

5. Consider working environment. Do not use the product in the rain or in a damp environment. Keep work area well lit. Do not use power tools near gasoline or flammable liquids. Keep workshop at a comfortable temperature so your hands are not cold. Connect machines that are used in the open via a residual current device (RCD) with an actuation current of 30 mA maximum. Use only extension cables that are approved for outdoor use.
6. The accessory or attachment must be kept level and stable at all times.
7. Keep work area clean. Cluttered workshops and benches can cause injuries. Ensure there is sufficient room to work safely.
8. Secure idle tools. When not in use, tools should be stored in a dry and high or locked up place, out of reach of children.
9. For best control and safety use both hands on the power tool and attachment. Keep both hands away from cutting area. Always wait for the spindle and cutter to stop rotating before making any adjustments.
10. Always keep guards in place and in good working order.
11. Remove any nails, staples and other metal parts from the workpiece.
12. Maintain tools and cutters with care. Keep cutters sharp and clean for better and safer performance. Do not use damaged cutters. Follow instructions for lubricating and changing accessories. Keep handles dry, clean and free from oil and grease.
13. Maintain accessories. Do not use damaged accessories. Only use accessories recommended by the manufacturer.
14. Check damaged parts. Before operation inspect the attachment, the power tool, the cable, extension cable and the plug carefully for signs of damage. Check for alignment of moving parts, binding, breakage, mounting and any other conditions that may effect its operation. Have any damage repaired by an Authorised Service Agent before using the tool or accessory. Protect tools from impact and shock.
15. Do not use tool if switch does not turn it on or off. Have defective switches replaced by an Authorised Service Agent
16. Don't over reach. Keep proper footing and balance at all times. Do not use

awkward or uncomfortable hand positions.

17. Don't abuse the cable. Never carry power tool or accessory by cord or pull it to disconnect from the socket. Keep cord from heat, oil and sharp edges. Always trail the power cord away from the work area.
18. Connect dust extraction equipment. If devices are provided for the connection of dust extraction and collection facilities, ensure these are connected and properly used.
19. Check all fixing and fastening nuts, bolts and screws on power tool, attachment and cutting tools before use to ensure they are tight and secure. Periodically check when machining over long periods.
20. Stay alert. Watch what you are doing. Use common sense. Do not operate tools when you are tired, under the influence of drugs or alcohol.
21. Personal Protective Equipment (PPE) for eye, ear and respiratory protection must be worn. All PPE must meet current UK and EU legislation.
22. Do not leave tools running unattended. Do not leave tool until it comes to a complete stop.
23. Always clamp workpiece being machined securely.
24. Only use cutting tools for woodworking that meet EN847-1/2 safety standards, and any subsequent amendments.
25. Vibration levels. Hand held power tools produce different vibration levels. You should always refer to the specifications and relevant Health & Safety Guide.

Routing Safety

1. Read and understand instructions supplied with power tool, attachment and cutter.
2. Keep hands, hair and clothing clear of the cutter.
3. Remove adjusting keys and spanners. Check to see that keys and adjusting spanners are removed from the router tool, cutter and attachment before turning router on. Make sure cutter can rotate freely.
4. Noise. Take appropriate measures for the protection of hearing if the sound pressure of 85dB(A) is exceeded. Routing sound pressure may exceed 85dB(A), so ear protection must be worn.
5. Eye protection. Always wear eye protection in the form of safety goggles, spectacles or visors to protect the eyes.

6. Respiratory protection. Wear a face or dust mask, or powered respirator. Dust masks/filters should be changed regularly.
7. Do not switch router on with the cutter touching the workpiece. At the end of the cut, release the router plunge and allow spindle to stop rotating. Never use the spindle lock as a brake
8. The direction of routing must always be opposite to the cutter's direction of rotation. Do not back-cut or climb-cut.
9. Check before cutting that there are no obstructions in the path of the router. Ensure there are no obstacles beneath workpiece when cutting full thickness, and that a sacrificial work surface is used.

Router Cutter Safety

1. Cutting tools are sharp. Care should be taken when handling them. Do not drop cutters or knock them against hard objects. Handle very small diameter cutters with extra care. Always return cutter to its packaging after use.
2. Always use cutters with a shank diameter corresponding to the size of the collet installed in your tool.
3. The maximum speed (n.max) marked on the tool, or in instructions or on packaging shall not be exceeded. Where stated the speed range shall be adhered to. Recommended speeds are shown in the Trend Routing Catalogue and/or website.
4. Always use router cutters in a router. Drill and boring bits must not be used in a router. Router cutters must only be used for the material cutting application for which they are designed. Do not use on metal or masonry.
5. Never use cutters with a diameter exceeding the maximum diameter indicated in the technical data of the powertool or attachment used.
6. Before each use check that the cutting tool is sharp and free from damage. Do not use the cutting tool if it is dull, broken or cracked or if in any other damage is noticeable or suspected.
7. Cutters should be kept clean. Resin build up should be removed at regular intervals with Resin Cleaner. The use of a PTFE dry lubricant will reduce resin build up. Do not use PTFE spray on plastic parts.
8. When using stacked tooling (multi-blade, block and groover etc.) on a spindle arbor, ensure that the cutting edges are staggered to each other to reduce the cutting impact.
9. Cutter shanks should be inserted

into the collet all the way to the line indicated on the shank. This ensures that at least ¾ of the shank length is held in the collet. Ensure clamping surfaces are cleaned to remove dirt, grease, oil and water.

10. Observe the correct assembly and fitting instructions in the router instruction manual for fitting the collet, nut and cutter.
11. Tool and tool bodies shall be clamped in such a way that they will not become loose during operation. Care shall be taken when mounting cutting tools to ensure that the clamping is by the shank of the cutting tool and that the cutting edges are not in contact with each other or with the clamping elements.
12. It is advisable to periodically check the collet and collet nut. A damaged, worn or distorted collet and nut can cause vibration and shank damage. Do not over-tighten the collet nut
13. Do not take deep cuts in one pass; take several shallow or light passes to reduce the side load applied to the cutter and router. Too deep a cut in one pass can stall the router.
14. In case of excessive vibrations whilst using the router stop immediately and have the eccentricity of the router, router cutter and clamping system checked by competent personnel
15. All fastening screws and nuts should be tightened using the appropriate spanner or key and to the torque value provided by the manufacturer.
16. Extension of the spanner or tightening using hammer blows shall not be permitted.
17. Clamping screws shall be tightened according to instructions provided by the manufacture. Where instructions are not provided, clamping screws shall be tightened in sequence from the centre outwards.

Using Routers In A Fixed Position

1. Attention should be made to the HSE's Safe Use of Vertical Spindle Moulding Machines Information Sheet No.18 and any revisions.
2. After work, release the router plunge to protect the cutter.
3. Always use a push-stick or push-block when making any cut less than 300mm in length or when feeding the last 300mm of the cut.
4. The opening around the cutter should be reduced to a minimum using suitably sized insert rings in the table and closing the back fence cheeks or fitting a false fence on the back fence.
5. Whenever possible use a work

holding device or jig to secure component being machined. Ensure any attachment is securely fitted to the workbench, with table surface at approximately hip height.

6. Use a No-Volt Release Switch. Ensure it is fixed securely, easily accessible and used correctly.
7. In router table (inverted) mode, stand to the front right of the table. The cutter will rotate anti-clockwise when viewed from top so the feed direction is from the right (against the rotation of the cutter). In overhead mode, stand to the front left of the machine table and the feed direction is from the left.
8. Do not reach underneath table or put your hands or fingers at any time in the cutting path while tool is connected to a power supply.
9. Never thickness timber between the back of the cutter and the backfence.

Useful Advice When Routing

1. Judge your feed rate by the sound of the motor. Feed the router at a constant feed rate. Too slow a feed rate will result in burning.
2. Trial cuts should be made on waste material before starting any project.
3. When using some attachments e.g. a router table or dovetail jig, a fine height adjuster is recommended.
4. When using a template guide bush, ensure there is sufficient clearance between cutter tip and inside edge of bush and that it cannot come into contact with collet and nut. Ensure cutter and guide bush are concentric.

Router Cutter Repair/Maintenance

1. Repair of tools is only allowed in accordance with the manufacturers instructions.
2. The design of composite (tipped) tools shall not be changed in process of repair. Composite tools shall be repaired by a competent person i.e. a person of training and experience, who has knowledge of the design requirements and understands the levels of safety to be achieved.
3. Repair shall therefore include, e.g. the use of spare parts which are in accordance with the specification of the original parts provided by the manufacturer.
4. Tolerances which ensure correct clamping shall be maintained.
5. Care shall be taken that regrinding of the cutting edge will not cause weakening of the body and the connection of the cutting edge to the body.

ITEMS ENCLOSED

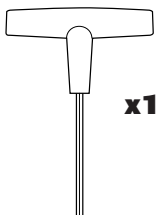
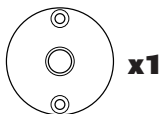
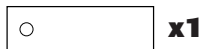

When unpacking the Ref. HINGE/JIG, the cardboard tube and endcaps should be retained. Adequate protection can be gained by returning the jig to the tube and replacing the endcap for storage and transportation.

ITEMS REQUIRED

- 1/4" collet plunge router.
- 12mm diameter router cutter with 1/4" shank.
- Door clamping device.
- Hand tools.
- Corner chisel or chisel.

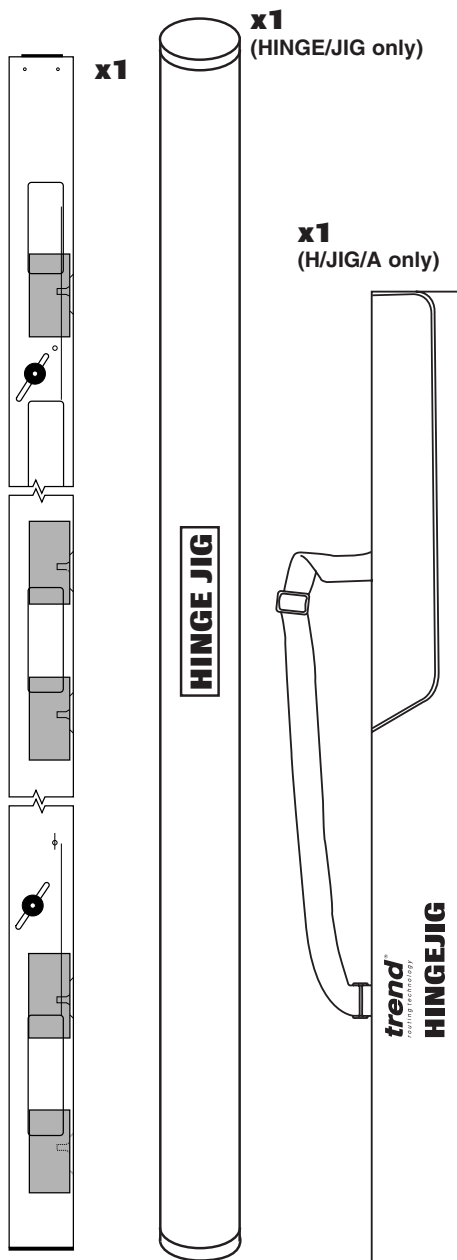

DESCRIPTION OF PARTS & ASSEMBLY - HINGE/JIG

The Ref. HINGE/JIG is already assembled. Please use drawing below to identify the parts. For fire doors the middle block will need to be moved up to the second aperture.

- A. Jig body
- B. Aperture block
- C. Aperture block retaining screw
- D. Edge stop
- E. Edge stop retaining screw
- F. Swivel end plate and screw
- G. Bradawl hole
- H. End bung
- I. Hinge width scribe line
- J. Template guide bush 16mm with extra long spigot
- K. Hex key 'T' handle 4mm A/F
- L. Bradawl
- M. Nylon spacer
- N. Spacer gauge 4mm
- O. Fire door aperture

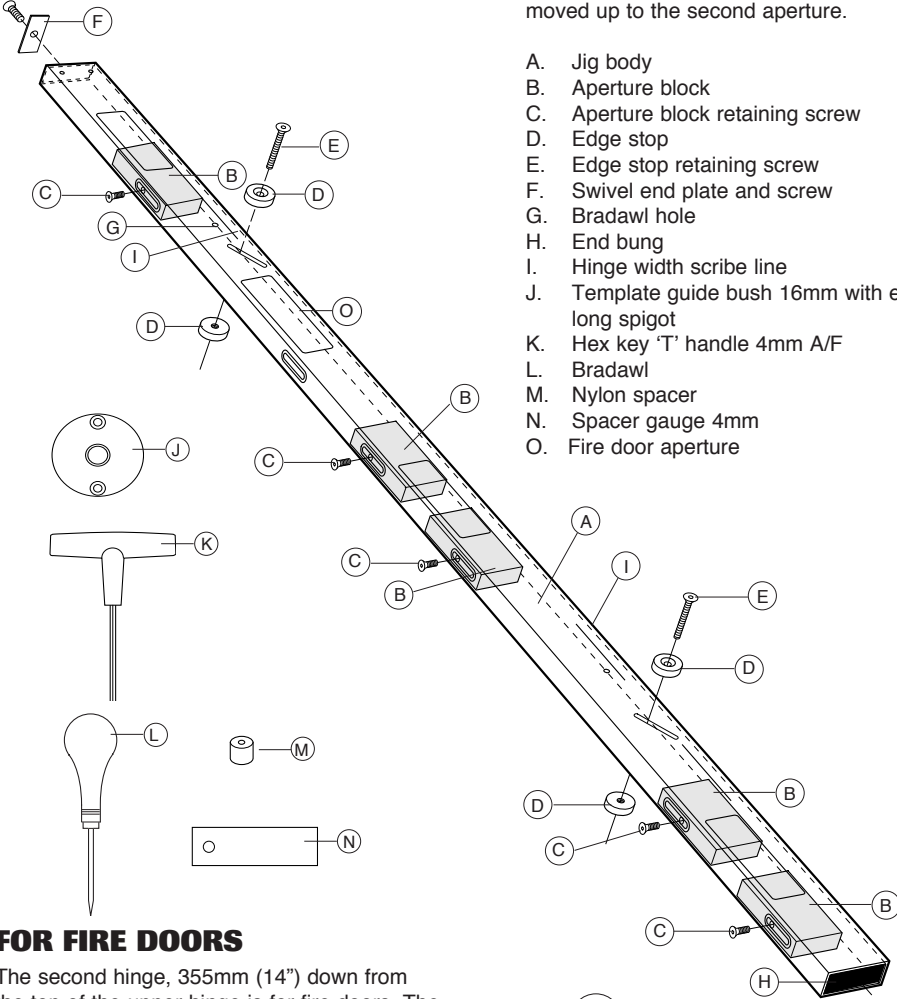

FOR FIRE DOORS

The second hinge, 355mm (14") down from the top of the upper hinge is for fire doors. The middle aperture block is moved up to the second aperture position and set to hinge length. The middle aperture is not then used.



Please note the cutter will create radius corners in the recess which will need to be squared off with a chisel or corner chisel.

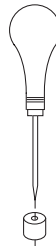

Put one plastic spacer onto each bradawl blade. Take care of the sharp point. When using bradawls always make sure the spacers are fitted.

Bradawls are sharp! Please take care.

ASSEMBLY - H/JIG/A

The two part hinge jig is designed for ease of transport. Once the jig is assembled the functions are exactly the same as the one piece model. The jointer block should already be fixed into the upper (short) section of the jig. The lower (long) section can then be connected, ensuring that the screws are correctly aligned.

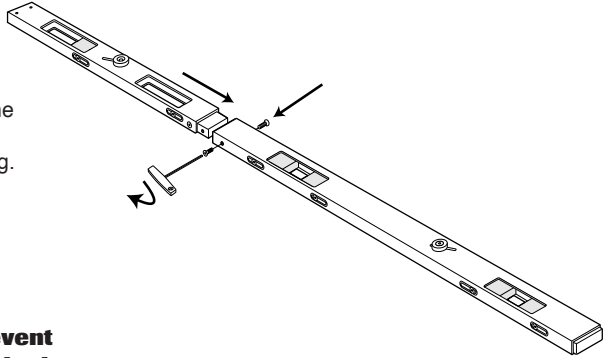

Incorrect orientation will prevent correct connection of the jig body.

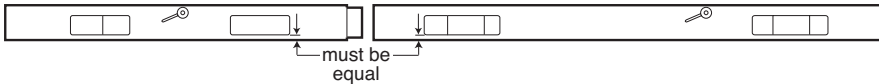

Setting up the Plunge Router 

This fits directly to the Trend T5 Router. To fit the guide bush to other makes and models, a universal sub-base Ref. UNIBASE or circular sub-base Ref. GB/5 can be used. The Ref. UNIBASE is designed to suit the most popular plunge type routers (please see our website for compatibility). The Ref. GB/5 can be re-drilled by the user.

- Fit the guide bush to the base of the router using the screws supplied with the router.
- The Ref. UNIBASE Universal Sub-base has a central recess to allow fitting of the special guide bush Ref. GB160. The sub-base is supplied drilled to fit the most popular makes of routers.

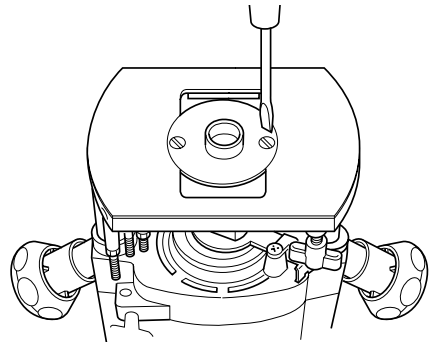

If there is any doubt about the concentricity of the cutter relative to the guide bush, then a false sub-base should be used in order to ensure an accurate fit of hinges. For all other makes of router, the sub-base to suit your router will need to be purchased.



The T4 router will require a Unibase to accept the guide bush or special accessory guide bush Ref. GB/T4/160 can be used.



It is recommended that a plunge router is used with the hinge jig.

Fitting the Router Cutter 

- The recommended router cutters for use with the jig are Refs. 3/8LX1/4TC, C019AX1/4TC or TR12X1/4TC.
- The cutters must have a 12.0mm diameter and a minimum overall length of 66mm.
- Unplug router from mains, insert 25mm of shank of cutter into collet and gently tighten collet nut.

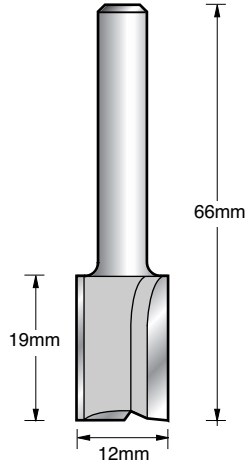

The guide bush must be concentric to the router collet assembly and router cutter. Before and during use please ensure the router cutter does not come into contact with the inside of the guide bush. When it is safe to do so check cutter and guide bush will not come into contact.

Template Guide Bush Principle

- The cross-section below shows the cutter being guided by the guide bush around one of the apertures.

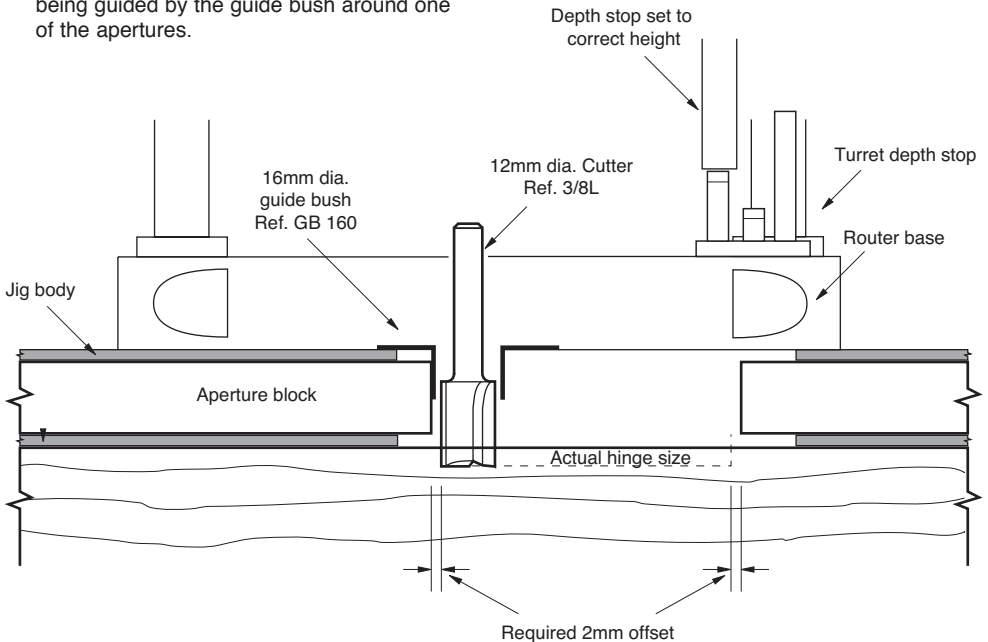

OPERATION   

Setting the Jig for Hinge Recessing

The jig has three sets of adjustments which require setting depending on the door size and thickness, as well as the size and positions of the hinges. These are all carried out with the 4mm hex key provided with the jig, one hinge and the 4mm feeler gauge.

The following setting up operation will only need to be carried out once for a set of doors having the same height dimensions and hinge sizes.

Setting the Width of the Recess for Standard Hinges.

The width of the recess for the hinge leaf is governed by the two edge stops. These engage onto the edge of the door or frame and their position governs the width of the recess. The position of each of the two edge stops are set as follows:-

- Undo the edge stop retaining screw with the hex key.
- Place one leaf of the hinge against the edge stop.
- Move edge stop along the slot until leaf edge of hinge lines up with the inside of the scribe line.
- Tighten edge stop retaining screw with the hex key.

Setting the Positions of the Recess

The jig has been designed to cater for the traditional positions of the hinges on a door as follows:

- Top hinge - Located 150 mm (6") from the top of the door.
- Bottom hinge - Located 200 mm (9") from the bottom of the door.
- Centre hinge - Centrally between the top and bottom hinges.



For fire doors, this jig will allow a second hinge 355mm down from the top of the upper hinge. To use with a fire door, move the middle aperture block up to the second aperture position and set to hinge length.

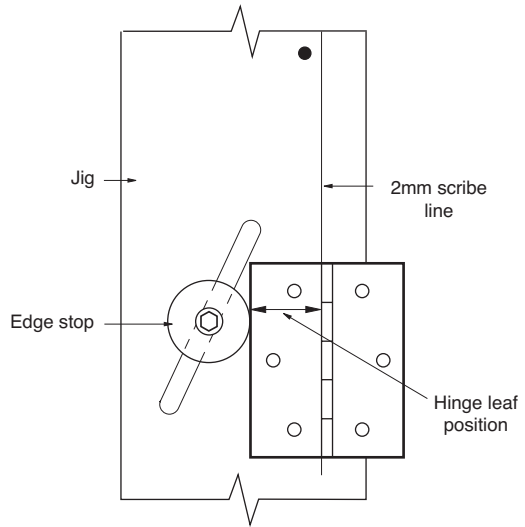

Lay the jig onto a flat surface e.g. the edge of the door. The procedure for setting the position of each hinge is as follows:

- Slacken block retaining screw of upper aperture block.
- Measure required position of hinge using tape measure.
- Slide block to required position.
- Tighten block retaining screw.

The top aperture has no upper block as it is fixed at 150mm (6") position from the top of the door. If only two hinges are used, then only the top and bottom apertures of the jig will be used.

Setting the Length of the Recess

The length of the recess for the hinge is governed by the lower aperture blocks which can be adjusted for hinges of length 75mm to 105mm. The 4mm spacer gauge is used to give the necessary offset. The procedure is as follows for each of the three apertures:-

- Place one hinge lengthways into the aperture.
- Slacken block retaining screw of lower aperture block.
- Place spacer gauge between hinge and upper aperture block.
- Slide lower block up to hinge.
- Tighten block retaining screw.

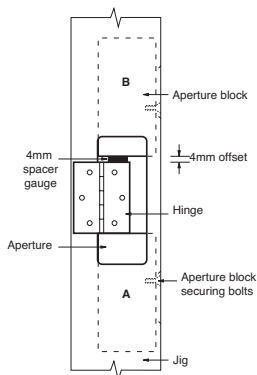

Ensure working position is comfortable, especially when setting up the jig and routing a hinge recess in a door.

Setting the Depth of the Recess

The depth of the recess must be the same thickness as the hinge or slightly deeper. Most routers are fitted with a depth stop to limit the depth of plunge of the router. Refer to your router's instruction manual for particular details on using the depth stop. The depth of the recess for the hinge is set as follows:

- Release depth gauge on the router.
- Place jig onto the edge of the door.
- Place router onto jig and locate guide bush into one of the apertures of the jig.
- Plunge cutter through aperture until it touches the edge of the door.
- Lock the router's carriage in this position.
- Move depth gauge up by the thickness of the hinge by:
 1. Either using the depth gauge measurement/dial
or
 2. Placing a leaf of the hinge between the depth gauge and the stop.
- Lock off depth stop and remove hinge.
- Check the depth of the cutter is correct by first fully plunging the router and locking the plunge mechanism. Invert the router and place the jig over the guide bush, now check that the cutter protrudes past the template the same distance as the thickness of the hinge.

Double check all settings, ensure all screws are tight. Setting up is complete.



Routing Hinge Recesses in the Door 

- The door should be laid on its edge with the hanging edge of the door facing upwards. Use the conventional block and wedge to keep the door securely in this position. Alternatively clamp the bottom of the door into the jaws of a Black & Decker® Workmate®.
- Place the Hinge Jig onto the edge of the door. Ensure that the Jig is placed the correct way round so that the edge stops are on the knuckle edge of the door. The swivel end plate should be at the top of the door.
- Rotate the swivel end plate through 90° and slide the jig down the door until the swivel end plate touches the top of the door.
- Push the jig up to the door so that the edge stops touch the opening face of the door.
- Without letting the jig move, locate the bradawls into the bradawl holes.
- Hammer the bradawls carefully into the edge of the door until the nylon spacer fitted to the bradawls touch the face of the jig.
- Now plug in the router and place the router with cutter and guide bush fitted into the first aperture of the jig.
- Switch router on and wait for the motor to reach full running speed. Electronic speed controlled routers should be set to the maximum speed.



The swivel end plate fixing screw may need to be loosened slightly.



Check the plastic spacer is on each bradawl before use.



To prevent damaging the jig template make sure the routers plunge is fully released after completing the cut.



- Position the guide bush in the corner of the aperture and plunge cutter until correct depth is reached. Lock the carriage of the router in this position. Rout around the aperture in a clockwise direction, then remove the waste from the centre of the aperture. See drawings below for direction of cut to prevent breakout.

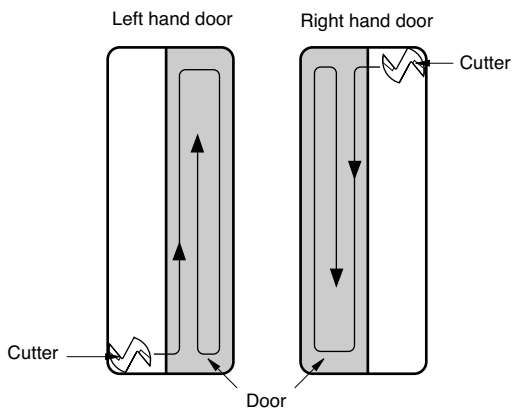

- Release the carriage of the router and repeat the procedure for the remaining apertures.
- Switch off router and remove jig from door by pulling out bradawls with a twisting action.
- Square off rounded corners of hinge recess with a corner chisel Ref. C/CHISEL and hammer.

Routing Hinge Recesses in the Frame 

- No adjustments are necessary to the jig or the router.
- Swivel the end plate through 90°.
- Using the opposite side of the Jig, butt the top of the jig into the head of the frame and up against the hanging jamb until the edge stops touch the opening edge of the frame.
- Without letting the jig move, locate the bradawls into the bradawl holes.
- Hammer the bradawls carefully into the door frame until the nylon spacer fitted to the bradawl touches the face of the jig.
- Now plug in the router and place the router with cutter and guide bush fitted, into the first aperture of the jig.



Extra care must be taken when routing top hinge



Check the plastic spacer is on each bradawl before use.



Ensure working position is comfortable. Keep proper footing and balance at all times, especially when routing a recess in a frame.

- Position the guide bush in any corner of aperture and plunge cutter into frame until depth, set by depth stop, is reached. Lock the carriage of the router in this position. Immediately start routing around the aperture in a clockwise direction. Then remove the waste from the centre of the aperture.

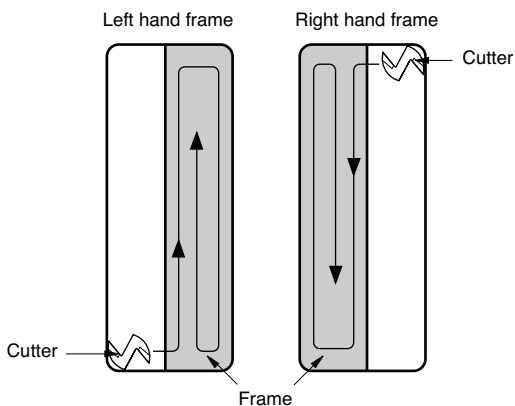

- Release the carriage of the router and repeat the procedure for the remaining apertures.
- Switch off router and remove jig from frame by pulling out bradawls with a twisting action.
- Square off rounded corners of hinge recess with a corner chisel Ref. C/CHISEL and hammer.
- After use of the jig, the Ref. H/JIG/A can be disassembled by loosening and removing the screws and pulling apart the two extrusions. Keep edge stops fitted. Return jigs and parts to storage/carry case.



Release the plunge action on the router after each hinge, as not doing so could result in cutting into the edge of the jig and causing damage. If you damage the jig or blocks, an epoxy resin (e.g. Araldite[®] Epoxide Resin) can be used to fill the gap and if rubbed smooth will provide a continuous edge on which the guide bush can follow.



Fitting the Door

- Fit hinges to door and raise upright.
- Use a jack to raise door until hinges align with recess.
- Screw leaves to frame.

Providing procedure is carried out correctly and that the frame/lining is plumb and parallel, then no adjustment should be necessary due to the identical mirror image positioning of the recesses in both the door and the frame.

Other Points

If a larger gap is required to accommodate smoke seal or draft excluder, a packing piece can be temporarily glued or stuck to the swivel end plate in order to utilise the jig in the same technique and achieve accurate results.

If a new door is being hung in an existing frame or lining, the door height may be shortened by a timber threshold or parquet flooring or by a new screed. This may cause problems with the jig fitting the door.

Finishing the Frames

The holes left by the bradawls are on both closing edges of the door and frame and are very unobtrusive. These can be easily filled with a matching coloured filler.

ACCESSORIES

Please use only Trend original accessories.

- | | |
|-----------------|---|
| Ref. 3/8LX1/4TC | 12mm diameter router |
| TR12X1/4TC | cutter with extra long |
| C019AX1/4TC | shank. |
| Ref. HJ/1 | Pair of 3mm thick steps when architrave is fitted 4mm back from lining. |
| Ref. D/STAND/A | Door stand to hold the door whilst routing. |
| Ref. D/CLAMP/A | Door clamp to hold the door whilst drilling and fitting locks. |
| Ref. C/CHISEL | Corner chisel for squaring corners of hinge recesses. |



MAINTENANCE

This jig has been designed to operate over a long period of time with a minimum of maintenance. Continual satisfactory operation depends upon proper tool care and regular cleaning.

Cleaning

- Regularly clean the jig and remove resin build-up on all threads.

Lubrication

- Your jig requires no additional lubrication.

Storage

- After use, store jig in its storage tube/carry case.

ENVIRONMENTAL PROTECTION

Recycle raw materials instead of disposing as waste.

Packaging should be sorted for environmental-friendly recycling.

The product and its accessories at the end of its life should be sorted for environmental-friendly recycling.

GUARANTEE

The jig carries a manufacturers guarantee in accordance with the conditions of the enclosed guarantee card.

Please use only Trend original spare parts.

HINGE/JIG & H/JIG/A - SPARE PARTS LIST			v6.0 02/2011
No.	Qty	Desc.	Ref.
1	1	Aluminium Template (HINGE/JIG)	WP-HJ/01
1A	1	Aluminium Template Upper (Short) (H/JIG/A)	WP-HJ/01A
1B	1	Aluminium Template Lower (Long) (H/JIG/A)	WP-HJ/01B
2	5	Aperture Block	WP-HJ/02
3	2	Upper Edge Stop	WP-HJ/03
4	2	Lower Edge Stop	WP-HJ/04
5	1	End Block	WP-HJ/05
6	1	Swivel End Plate	WP-HJ/06
7	1	End Bung	WP-HJ/07
8	2	Nylon Spacer	WP-HJ/08
9	2	Bradawl	WP-HJ/09
10	1	Feeler Gauge 4mm	WP-HJ/10
11	1	Hinge Jig Label	WP-HJ/11
12	5	Jointing Block - H/JIG/A	WP-HJ/12
13	5	Machine Screw Csk M6 x 16mm Skt	WP-SCW/51
14	2	Machine Screw Csk M6 x 40/18mm Skt	WP-SCW/52
15	1	Machine Screw Small Csk M6 x 12mm Skt	WP-SCW/56
16	2	Split Pin 3mm x 25mm	WP-PIN/01
17	1	Hex Key 'T' Handle 4mm	WP-AKT/01
18	1	Guide Bush 16mm Dia. x 10mm Spigot	GB160
19	1	Storage Tube (HINGE/JIG)	CASE/HJ
20	1	Carry Case (H/JIG/A)	CASE/HJ/A
21	1	Manual	MANU/HJ

HINGE/JIG & H/JIG/A - SPARE PARTS DIAGRAM

v6.0 02/2011

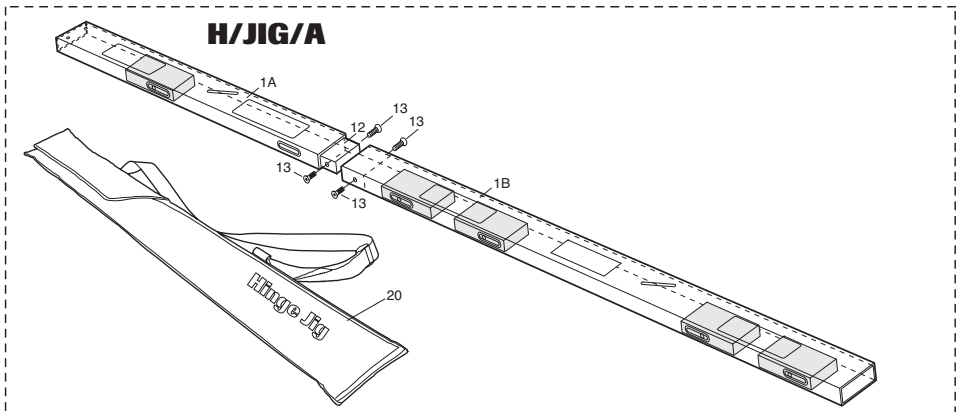
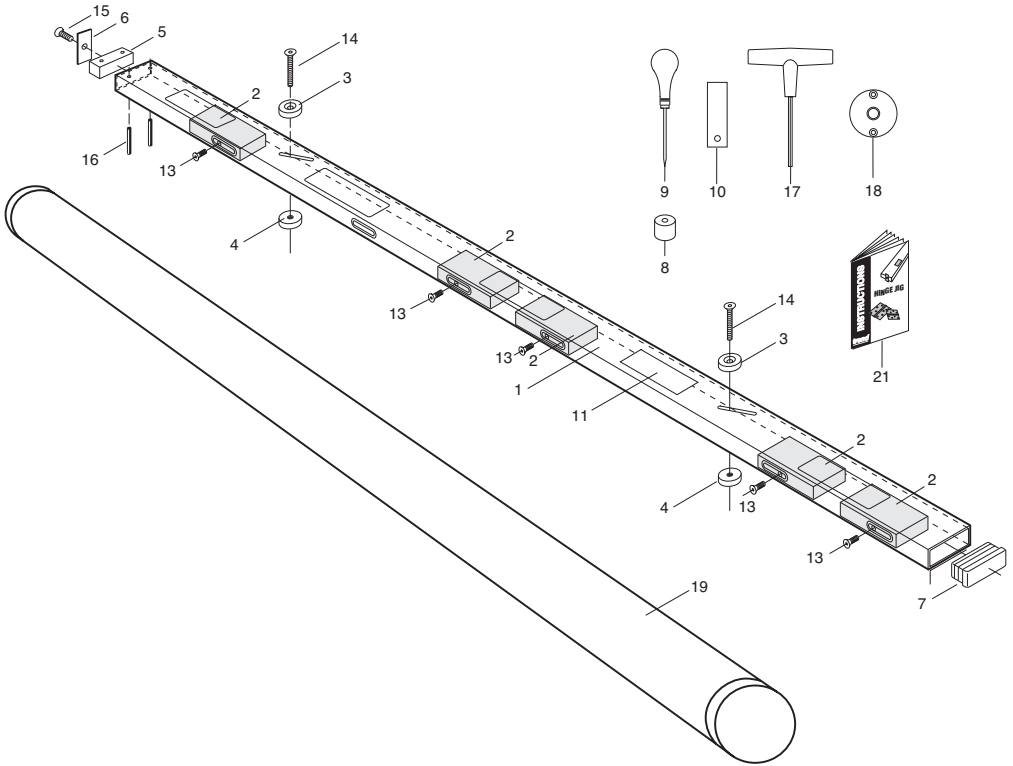

QUICK START INSTRUCTIONS

These instructions are provided for those who are confident with the router and are already familiar with the Hinge Jig.

Setting Up

1. Fit router cutter & guide bush to router.
2. Position door with hanging edge uppermost.
3. Adjust two edge stops to width of hinge.

Routing the Door

1. Place hinge jig on hanging edge of door.
2. Rotate the end plate at 90° to jig.
3. Ensure end plate touches end of door.
4. Ensure edge-stops touch opening face of door.
5. Secure jig to door using the two bradawls.
6. Adjust top blocks to position of hinges.
7. Adjust bottom blocks to length of hinges.
8. Adjust depth stop on router to thickness of hinge.
9. Switch router on & locate guide bush into aperture.
10. Plunge down router and rout clockwise.
11. Repeat routing operation for each hinge recess.
12. Chisel corners square by hand to receive hinges or use the corner chisel Ref. C/CHISEL.

Routing the Frame

1. Rotate the end plate until flush with jig.
2. Butt the end plate into the head of frame.
3. Ensure edge-stops touch edge of frame.
4. Secure jig to door frame using the two bradawls.
5. Locate guide bush into aperture and switch router on.
6. Plunge down router and rout clockwise.
7. Repeat routing operation for each hinge recess.
8. Chisel corners square by hand to receive hinges or use the corner chisel Ref. C/CHISEL.

MANU/HJ v8.0



RECYCLABLE

Trend Machinery & Cutting Tools Ltd.

Odhams Trading Estate St Albans Road
Watford WD24 7TR England

Tel: 0044(0)1923 249911

technical@trendm.co.uk

www.trend-uk.com