

Dear Customer

Thank you for purchasing this Trend product, we hope you enjoy many years of creative and productive use.

This jig should give lasting performance if used in accordance with these instructions.

## CONTENTS

<b>TECHNICAL DATA</b> _____	<b>1</b>
<b>SAFETY</b> _____	<b>2-3</b>
<b>ITEMS ENCLOSED</b> _____	<b>4</b>
<b>DESCRIPTION OF PARTS</b> _____	<b>4</b>
<b>ACCESSORIES</b>	
– Recommended Cutters _____	<b>5</b>
– Sub-base Set _____	<b>5</b>
– Guide Bushes _____	<b>6</b>
– Clamps _____	<b>6</b>
– Carry Case _____	<b>6</b>
<b>ASSEMBLY</b>	
– Measuring & Calculating Recess Size _____	<b>7</b>
– Marking out the Recess _____	<b>8</b>
– Example _____	<b>9</b>
<b>OPERATION</b>	
– Positioning the Jig on the Worktop _____	<b>10</b>
– Routing the Worktop _____	<b>11</b>
– Routing the Water Drip Groove / Channel _____	<b>11</b>
– Reduced Radius Corner _____	<b>12</b>
<b>MAINTENANCE</b> _____	<b>12</b>
<b>ENVIRONMENTAL PROTECTION</b> _____	<b>12</b>
<b>GUARANTEE</b> _____	<b>12</b>
<b>TROUBLESHOOTING</b> _____	<b>12</b>
<b>SPARE PARTS</b>	
– Spare Parts Diagram & List _____	<b>IB</b>

## TECHNICAL DATA

Jig thickness	12mm
Cutter size for routing recess	12.7mm
Cutter size for drip groove	R2.5mm radius
Guide bush size	30mm
Guide bush size (drip groove)	16mm
Standard corner radius	25mm
Reduced corner radius	7mm
Sink depth min.	440mm
Sink depth max.	515mm
Sink width max.	1050mm
Recess depth min.	445mm
Recess depth max.	520mm
Recess width max.	630mm or 1030mm*
Weight	3.68kg

\* if overlapping the longer slots.

The following symbols are used throughout this manual:



Denotes risk of personal injury, loss of life or damage to the tool in case of non-observance of the instructions in this manual.



Refer to the instruction manual of your power tool.

This unit must not be put into service until it has been established that the power tool to be connected to this unit is in compliance with 2006/42/EC (identified by the CE marking on the power tool).

## INTENDED USE

This jig is intended for use with a plunge router fitted with suitable guide bush and router cutter to rout the recesses into worktops for single or double Belfast Sinks and Butler Sinks.

The jig also enables you to accurately rout the drip channel groove on the underside of worktops.



If you require further safety advice, technical information or spare parts, please call Trend Technical Support or visit [www.trend-uk.com](http://www.trend-uk.com)

**SAFETY**



**WARNING:**

Observe the safety regulations in the instruction manual of the power tool to be used. Please read the following instructions carefully. Failure to do so could lead to serious injury. When using electric tools, basic safety precautions, including the following should always be followed to reduce the risk of fire, electric shock and personal injury. Also observe any applicable additional safety rules. Read the following safety instructions before attempting to operate this product.

**PLEASE KEEP THESE INSTRUCTIONS IN A SAFE PLACE.**

The attention of UK users is drawn to The Provision and Use of Work Equipment Regulations 1998, and any subsequent amendments.

Users should also read the HSE/HSC Safe Use of Woodworking Machinery Approved Code of Practice and Guidance Document and any amendments.

Users must be competent with woodworking equipment before using our products.

**IMPORTANT NOTE:**

Residual Risk. Although the safety instructions and operating manuals for our tools contain extensive instructions on safe working with power tools, every power tool involves a certain residual risk which cannot be completely excluded by safety mechanisms. Power tools must therefore always be operated with caution!

**General**

1. Disconnect power tool and attachment from power supply when not in use, before servicing, when making adjustments and when changing accessories such as cutters. Ensure switch is in "off" position. Always ensure cutter has stopped rotating.
2. Always mount the power tool, accessory or attachment in conformity with the instructions. Only use attachment and accessories specified in the power tool manual. The tool or attachment should not be modified or used for any application other than that for which it was designed. Do not force tool.
3. Keep children and visitors away. Do not let children or visitors touch the tool, accessory or attachment. Keep children and visitors away from work area. Make the workshop child proof with padlock and master switch.
4. Dress properly. Do not wear loose clothing or jewellery, they can be caught in moving parts. Rubber gloves and non-skid footwear is recommended when working outdoors. Wear protective hair

covering to contain long hair.

5. Consider working environment. Do not use the product in the rain or in a damp environment. Keep work area well lit. Do not use power tools near gasoline or flammable liquids. Keep workshop at a comfortable temperature so your hands are not cold. Connect machines that are used in the open via a residual current device (RCD) with an actuation current of 30 mA maximum. Use only extension cables that are approved for outdoor use.
6. The accessory or attachment must be kept level and stable at all times.
7. Keep work area clean. Cluttered workshops and benches can cause injuries. Ensure there is sufficient room to work safely.
8. Secure idle tools. When not in use, tools should be stored in a dry and high or locked up place, out of reach of children.
9. For best control and safety use both hands on the power tool and attachment. Keep both hands away from cutting area. Always wait for the spindle and cutter to stop rotating before making any adjustments.
10. Always keep guards in place and in good working order.
11. Remove any nails, staples and other metal parts from the workpiece.
12. Maintain tools and cutters with care. Keep cutters sharp and clean for better and safer performance. Do not use damaged cutters. Follow instructions for lubricating and changing accessories. Keep handles dry, clean and free from oil and grease.
13. Maintain accessories. Do not use damaged accessories. Only use accessories recommended by the manufacturer.
14. Check damaged parts. Before operation inspect the attachment, the power tool, the cable, extension cable and the plug carefully for signs of damage. Check for alignment of moving parts, binding, breakage, mounting and any other conditions that may effect its operation. Have any damage repaired by an Authorised Service Agent before using the tool or accessory. Protect tools from impact and shock.
15. Do not use tool if switch does not turn it on or off. Have defective switches replaced by an Authorised Service Agent
16. Don't over reach. Keep proper footing and balance at all times. Do not use awkward or uncomfortable hand positions.
17. Don't abuse the cable. Never carry

power tool or accessory by cord or pull it to disconnect from the socket. Keep cord from heat, oil and sharp edges. Always trail the power cord away from the work area.

18. Connect dust extraction equipment. If devices are provided for the connection of dust extraction and collection facilities, ensure these are connected and properly used.
19. Check all fixing and fastening nuts, bolts and screws on power tool, attachment and cutting tools before use to ensure they are tight and secure. Periodically check when machining over long periods.
20. Stay alert. Watch what you are doing. Use common sense. Do not operate tools when you are tired, under the influence of drugs or alcohol.
21. Personal Protective Equipment (PPE) for eye, ear and respiratory protection must be worn. All PPE must meet current UK and EU legislation.
22. Do not leave tools running unattended. Do not leave tool until it comes to a complete stop.
23. Always clamp workpiece being machined securely.
24. Only use cutting tools for woodworking that meet EN847-1/2 safety standards, and any subsequent amendments.
25. Vibration levels. Hand held power tools produce different vibration levels. You should always refer to the specifications and relevant Health & Safety Guide.

**Routing Safety**

1. Read and understand instructions supplied with power tool, attachment and cutter.
2. Keep hands, hair and clothing clear of the cutter.
3. Remove adjusting keys and spanners. Check to see that keys and adjusting spanners are removed from the router tool, cutter and attachment before turning router on. Make sure cutter can rotate freely.
4. Noise. Take appropriate measures for the protection of hearing if the sound pressure of 85dB(A) is exceeded. Routing sound pressure may exceed 85dB(A), so ear protection must be worn.
5. Eye protection. Always wear eye protection in the form of safety goggles, spectacles or visors to protect the eyes.
6. Respiratory protection. Wear a face or dust mask, or powered respirator. Dust masks/filters should be changed regularly.

7. Do not switch router on with the cutter touching the workpiece. At the end of the cut, release the router plunge and allow spindle to stop rotating. Never use the spindle lock as a brake
8. The direction of routing must always be opposite to the cutter's direction of rotation. Do not back-cut or climb-cut.
9. Check before cutting that there are no obstructions in the path of the router. Ensure there are no obstacles beneath workpiece when cutting full thickness, and that a sacrificial work surface is used.

### Router Cutter Safety

1. Cutting tools are sharp. Care should be taken when handling them. Do not drop cutters or knock them against hard objects. Handle very small diameter cutters with extra care. Always return cutter to its packaging after use.
2. Always use cutters with a shank diameter corresponding to the size of the collet installed in your tool.
3. The maximum speed (n.max) marked on the tool, or in instructions or on packaging shall not be exceeded. Where stated the speed range shall be adhered to. Recommended speeds are shown in the Trend Routing Catalogue and/or website.
4. Always use router cutters in a router. Drill and boring bits must not be used in a router. Router cutters must only be used for the material cutting application for which they are designed. Do not use on metal or masonry.
5. Never use cutters with a diameter exceeding the maximum diameter indicated in the technical data of the powertool or attachment used.
6. Before each use check that the cutting tool is sharp and free from damage. Do not use the cutting tool if it is dull, broken or cracked or if in any other damage is noticeable or suspected.
7. Cutters should be kept clean. Resin build up should be removed at regular intervals with Resin Cleaner. The use of a PTFE dry lubricant will reduce resin build up. Do not use PTFE spray on plastic parts.
8. When using stacked tooling (multi-blade, block and groover etc.) on a spindle arbor, ensure that the cutting edges are staggered to each other to reduce the cutting impact.
9. Cutter shanks should be inserted into the collet all the way to the line indicated on the shank. This ensures that at least  $\frac{3}{4}$  of the shank length is held in the collet. Ensure clamping

- surfaces are cleaned to remove dirt, grease, oil and water.
10. Observe the correct assembly and fitting instructions in the router instruction manual for fitting the collet, nut and cutter.
  11. Tool and tool bodies shall be clamped in such a way that they will not become loose during operation. Care shall be taken when mounting cutting tools to ensure that the clamping is by the shank of the cutting tool and that the cutting edges are not in contact with each other or with the clamping elements.
  12. It is advisable to periodically check the collet and collet nut. A damaged, worn or distorted collet and nut can cause vibration and shank damage. Do not over-tighten the collet nut
  13. Do not take deep cuts in one pass; take several shallow or light passes to reduce the side load applied to the cutter and router. Too deep a cut in one pass can stall the router.
  14. In case of excessive vibrations whilst using the router stop immediately and have the eccentricity of the router, router cutter and clamping system checked by competent personnel
  15. All fastening screws and nuts should be tightened using the appropriate spanner or key and to the torque value provided by the manufacturer.
  16. Extension of the spanner or tightening using hammer blows shall not be permitted.
  17. Clamping screws shall be tightened according to instructions provided by the manufacture. Where instructions are not provided, clamping screws shall be tightened in sequence from the centre outwards.

### Using Routers In A Fixed Position

1. Attention should be made to the HSE's Safe Use of Vertical Spindle Moulding Machines Information Sheet No.18 and any revisions.
2. After work, release the router plunge to protect the cutter.
3. Always use a push-stick or push-block when making any cut less than 300mm in length or when feeding the last 300mm of the cut.
4. The opening around the cutter should be reduced to a minimum using suitably sized insert rings in the table and closing the back fence cheeks or fitting a false fence on the back fence.
5. Whenever possible use a work holding device or jig to secure component being machined. Ensure any attachment is securely fitted to the workbench, with table surface at

- approximately hip height.
6. Use a No-Volt Release Switch. Ensure it is fixed securely, easily accessible and used correctly.
  7. In router table (inverted) mode, stand to the front right of the table. The cutter will rotate anti-clockwise when viewed from top so the feed direction is from the right (against the rotation of the cutter). In overhead mode, stand to the front left of the machine table and the feed direction is from the left.
  8. Do not reach underneath table or put your hands or fingers at any time in the cutting path while tool is connected to a power supply.
  9. Never thickness timber between the back of the cutter and the backfence.

### Useful Advice When Routing

1. Judge your feed rate by the sound of the motor. Feed the router at a constant feed rate. Too slow a feed rate will result in burning.
2. Trial cuts should be made on waste material before starting any project.
3. When using some attachments e.g. a router table or dovetail jig, a fine height adjuster is recommended.
4. When using a template guide bush, ensure there is sufficient clearance between cutter tip and inside edge of bush and that it cannot come into contact with collet and nut. Ensure cutter and guide bush are concentric.

### Router Cutter Repair/Maintenance

1. Repair of tools is only allowed in accordance with the manufacturers instructions.
2. The design of composite (tipped) tools shall not be changed in process of repair. Composite tools shall be repaired by a competent person i.e. a person of training and experience, who has knowledge of the design requirements and understands the levels of safety to be achieved.
3. Repair shall therefore include, e.g. the use of spare parts which are in accordance with the specification of the original parts provided by the manufacturer.
4. Tolerances which ensure correct clamping shall be maintained.
5. Care shall be taken that regrinding of the cutting edge will not cause weakening of the body and the connection of the cutting edge to the body.

Version 7.2 06/2013

**ITEMS ENCLOSED**

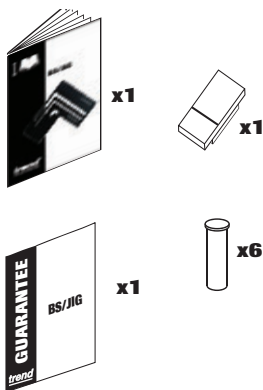
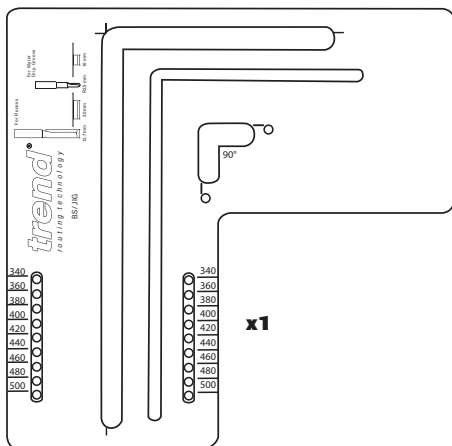

**ITEMS REQUIRED**

- 1/2" plunge router.
- 30mm guide bush.
- 16mm guide bush for drip groove.
- 12.7mm diameter x 50mm cut router cutter with 1/2" shank.
- R2.5mm radius cutter for drip groove.
- Clamps x 2.
- Hand tools.
- Trestles x 2.

**DESCRIPTION OF PARTS**

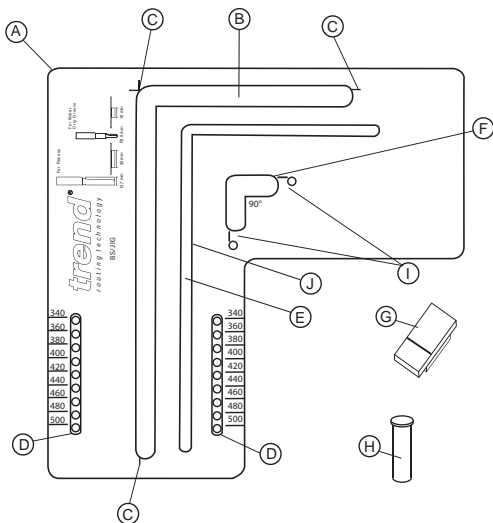

- (A) Jig body
- (B) Sink recess slot
- (C) Datum lines
- (D) Depth setting pin locations (20mm increments)
- (E) Water drip groove / channel slot
- (F) Reduced radius corner slot (7mm radius)
- (G) Sliding datum block
- (H) Pin
- (I) 90° corner pin locations
- (J) Water drip groove / channel slot inner edge

## ACCESSORIES

Please use only Trend original accessories.

### Recommended 1/2" x 50mm Straight Cutter

Ref. 3/83X1/2TC, 3/83DX1/2TC, C153X1/2TC, C153DX1/2TC.

C153, C153D, TR17, TR17D, 3/83, 3/83D

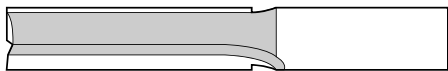

### Recommended R2.5mm Radius Cutter for Water Drip Groove

Ref. C051AX1/2TC

C051A



## Sub-base Set

Ref. UNIBASE

To obtain a perfect accurate close fitting joint, a 30mm guide bush must be used. The guide bush must always be fitted concentric with the cutter. This can be achieved using a Universal Sub-base and 30mm outside diameter guide bush ref. GB30.

The Universal Sub-base has a central recess to allow fitting of the guide bush to most makes of routers and is available ready to fit the most popular makes.

The Sub-base contains screws, a line up bush and two line up pins. The line up pins and bush ensure exact alignment of Sub-base with router spindle, when fitted with the relevant collet.

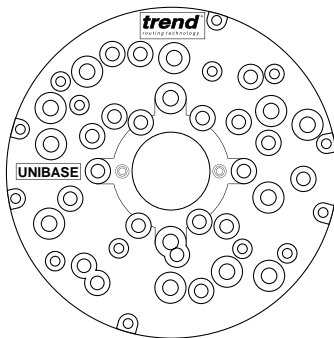

### General Instructions for Fitting Sub-bases to Router

1. Fit line up guide bush onto sub-base, with screws supplied.
2. Fit 12.7mm (1/2") shank line up pin into collet of router. Plunge router until pin projects through base and lock plunge.
3. Locate guide bush and sub-base assembly over protruding pin.
4. Line up fixing holes and fit screws.
5. Now tighten up screws.
6. Release plunge, remove line up bush and line up pin. Alignment should now be correct. Fit 30mm guide bush and cutter.
7. Periodically check the sub-base is concentric to the spindle of the router.

### Fits following router models

Atlas Copco OFSE2000 Bosch GOF 1300ACE, 1600A, 1700ACE Casals FT2000VCE DeWalt DW625EK, 629 Draper R1900V Elu MOF 31, 77, 98, 131, 177(E) Felisatti TP246(E), R346EC Festo OF2000E Freud FT2000E Hitachi MI12V, M12SA, TR12 Makita 3612BR, 3612(C) Metabo OF1612, OFE1812 Performance Pro CLM1250R >11/2003, CLM2050R Ryobi RE600N, R600N, RE601, R500, R502 Skil 1875U1 T-TECH TT/R127 Wadkin R500

**30mm Guide Bush**

Ref. GB30

30mm guide bush to fit sub-base.

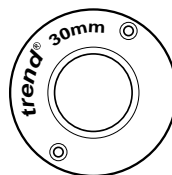

**16mm Guide Bush**

Ref. GB16

16mm guide bush (for drip groove) to fit sub-base.



---

**Clamps**

Ref. FC/200

Three heavy duty quick action or gripper clamps are required to secure the jig to the worktop.



**Whenever clamps are used, ensure they do not foul the router path and that they are securely tightened.**

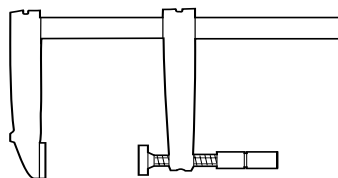

**ASSEMBLY**

**Measuring & Calculating Recess Size**



**The maximum cut distance when overlapping the horizontal slot is 630mm.**

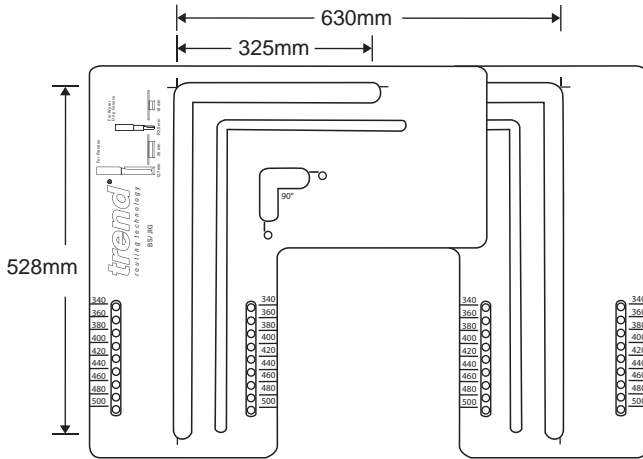

**The maximum cut distance when overlapping the vertical slots is 1030mm.**

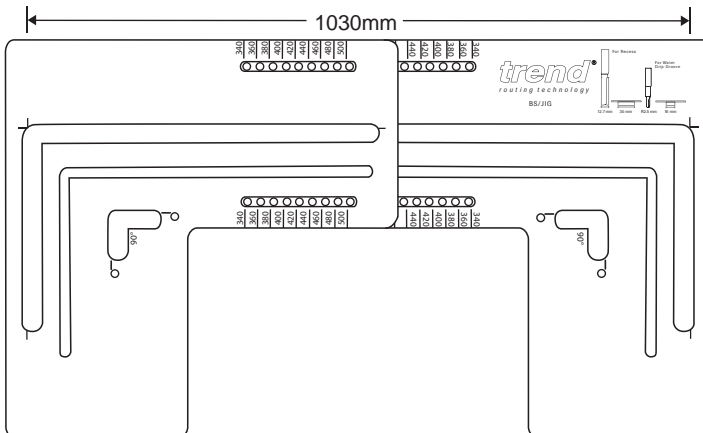

The pin holes for setting the depth are 20mm apart, therefore a packing piece may be needed if the jig needs to be set in between these increments, depending on the sink size. Although the sink manufacture provides the outer dimensions of the sink, it is important that the internal dimensions of the sink are measured to calculate the recess to be cut.

It is recommended that the worktop overlaps the sides and back of the sink by 10mm.

The front of the sink should project out from the worktop by half the sink wall thickness.

### Sink Dimensions

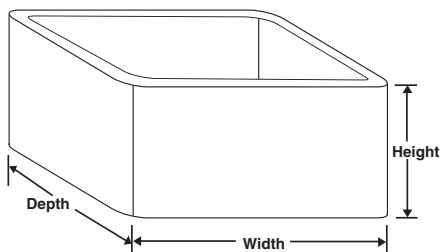

### Marking out the Recess

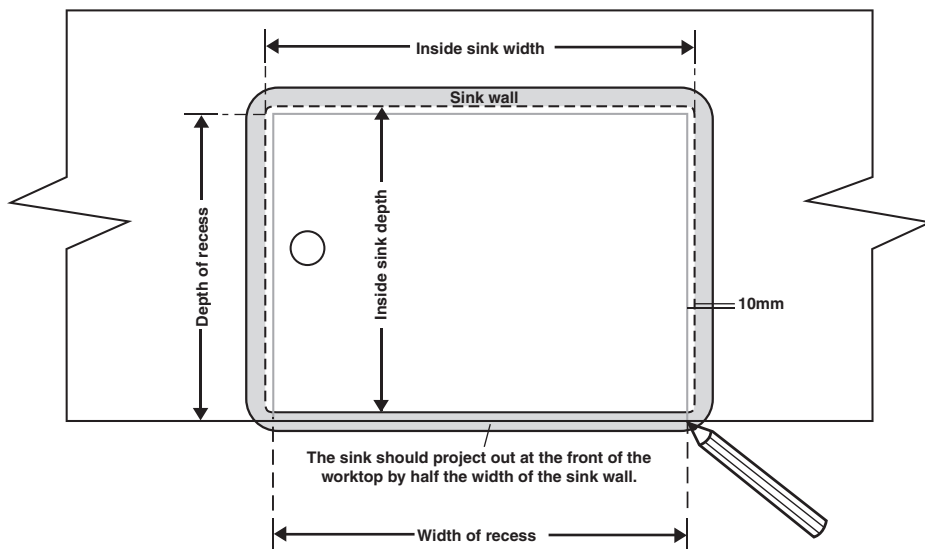

- Mark the width of the recess on the top of the worktop. This measurement can be calculated as follows: Inside sink width minus 20mm (2 x 10mm overhang).
- Mark the depth of the recess on the top. This measurement can be calculated as follows: Inside sink depth minus 10mm then add half the thickness of sink wall.
- Copy dimension marks to the underside of the worktop.



**If you are fitting a series of sinks of the same design, beware that the dimensions of ceramic sinks can vary slightly during manufacture, therefore each one should be measured individually to calculate the correct recess to be routed.**



**Example**

In the following example we will make calculations for a recess to fit a sink measuring 597mm wide x 460mm deep.

**Recess Width**

- The outside dimension of the sink width is 597mm, the thickness of the sink wall in this example is 30mm.
- Therefore 597mm minus 60mm (2 x wall thickness) = 537mm.
- Subtract the 10mm overhang for each side of the sink: 537mm minus 20mm = 517mm.
- This is the recess width to be cut.

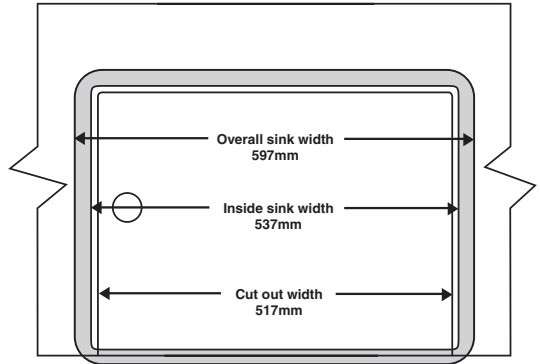

**Recess Depth**

- The outside depth dimension of the sink is 460mm, the sink wall thickness is 30mm.
- Therefore 460 minus 60mm (2 x wall thickness) = 400mm.
- Subtract only one 10mm overhang for the rear of the recess, but then add the thickness of the sink wall at the front, in this case half of 30mm = 15mm.
- Therefore 400mm minus 10mm (rear overhang) = 390mm plus 15mm (half sink wall thickness) = 405mm.
- This is the recess width to be cut.

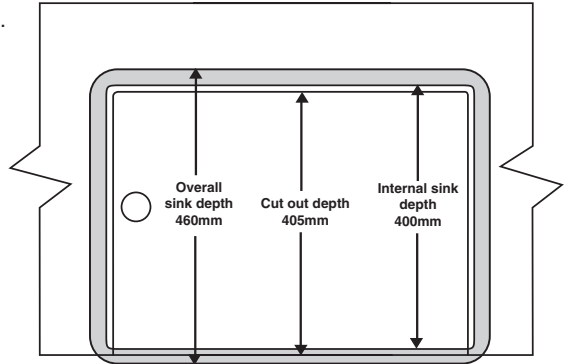

The overall recess to be cut is 517mm x 405mm.

**OPERATION**   

**Positioning the Jig on the Worktop** 

- Insert two pins into the jig to the sink depth required. The pins are designed to be a tight fit in the holes. Ensure pins are below the jig surface (this may require gentle tapping).
- If the measurement required is in between the 20mm increments, fit the pin in the next location and insert a packing piece. Using our example, if the width required is 405mm, fit the pin in the 420 location and fit 15mm packing piece.
- Offer the jig onto the worktop and line up the engraved marks on the jig with the recess markings.
- The jig will probably extend past the end of the worktop so far that the near datum line cannot be lined accurately. In this case the sliding datum block should be used.
- Clamp the jig in place for the left side, ensuring the clamps are clear from the path of the router.
- Remove sliding datum block.
- Before commencing with the cut, ensure that the area to be cut out is well supported from below and that the path of the cutter is clear.
- To remove pins, gently place jig on a flat surface so the pins touch the surface, push down on the jig and the pins will release.

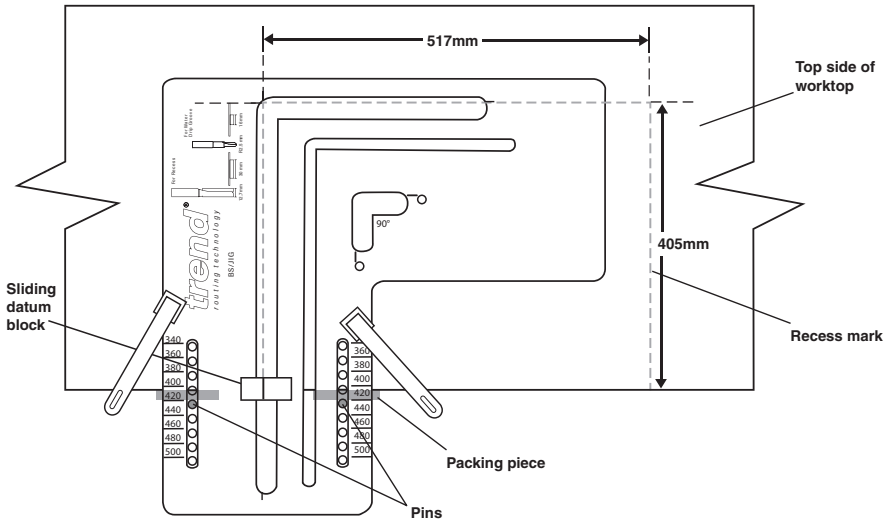

**The left hand of the recess is routed with the worktop faced upwards. The worktop is then turned upside down and the jig is repositioned to rout the remaining half.**



**Ensure worktop is securely held to trestles. Ensure jig is clamped securely to worktop and placed at a comfortable working height. Ensure pins are gently tapped into the holes to ensure the heads are below the jig surface.**

**Routing the Worktop** 

- With a 30mm guide bush and a 12.7mm cutter fitted to the router, set the depth of cut at approximately 8mm. Position the router in the sink recess slot, switch on the router, plunge down and rout the left half of the recess. Cut in from the worktop edge, travelling in a clockwise direction.
- Increase the depth of cut and repeat until cut is complete. At the end of each cut release plunge and switch off router.
- Remove the jig and then carefully turn the worktop upside down.
- To rout the second half of the recess, re-position the jig as shown. Remember to re-insert any packing piece that was used for routing the first half. The sliding datum block may be needed to line up.
- Clamp the jig in place. Remove the sliding datum block if used. Rout the remaining side, again ensuring that the worktop is supported, including the waste piece.

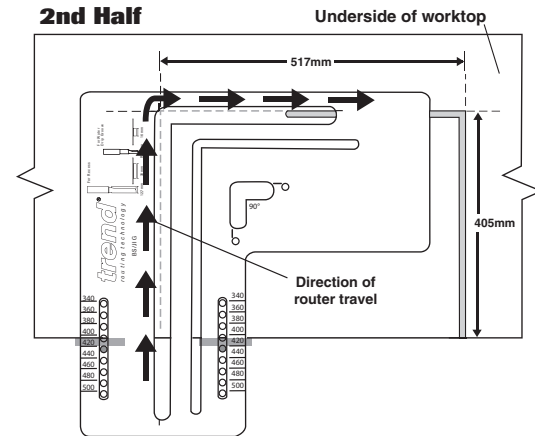
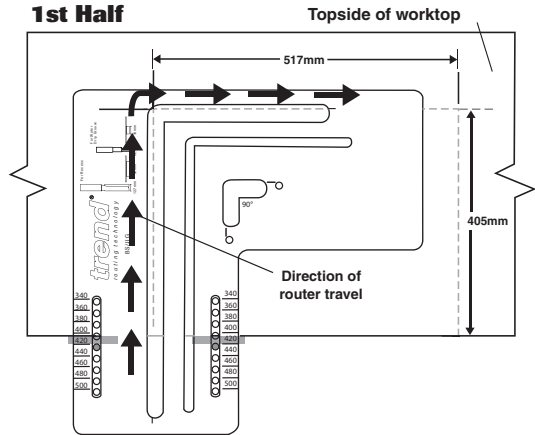

**Routing the Water Drip Channel** 

- A water drip channel can be routed to the underside of the worktop to allow water to drain off.
- Fit a 16mm guide bush and a R2.5mm radius cutter to the router.
- With the worktop surface faced downwards, line the inner edge of the jig's drip channel groove with the recess edge and clamp in place. This will give a drip channel about 5mm back from the recess.
- Set the router cutter to plunge about 5mm into the worktop. Ensure the 16mm guide bush is placed in the drip channel slot. Start the groove 5mm from the worktop front edge and rout in a clockwise direction.
- After the first half has been routed, re-position the jig for the second half and repeat the operation.
- Stop the groove 5mm before the worktop front edge.



**Ensure the drip groove starts 5mm in from the worktop front.**

After use, store jig carefully.

**Reduced Radius Corner Slot**



- It is possible to cut a smaller radius in the corners of the recess by using the small 90 degree cut slot.
- Fit two pins in the location holes ensuring they sit flush and push into the existing corner of the recess. Clamp the jig into place and rout in several passes.

**MAINTENANCE**



Please use only Trend original spare parts and accessories.

The jig has been designed to operate over a long period of time with a minimum of maintenance. Continual satisfactory operation depends upon proper tool care and regular cleaning.

**Cleaning**

- Regularly clean the jig with a soft cloth.

**Lubrication**

- Your jig requires no additional lubrication.

**Storage**

- After use, store jig in its packaging or it can be hung on a wall hook.

**ENVIRONMENTAL PROTECTION**

**Recycle raw materials instead of disposing as waste.**

Packaging should be sorted for environmental-friendly recycling.

The product and its accessories at the end of their life should be sorted for environmental friendly recycling.

**GUARANTEE**

The jig carries a manufacturers guarantee in accordance with the conditions on the enclosed guarantee card.

**TROUBLE SHOOTING**

<b>Fault</b>	<b>Cause</b>	<b>Remedy</b>
■ The back edge of the joint does not line up.	Jig has not been positioned squarely to the front edge. Or incorrect location of pegs or packing material.	If not enough material has been removed, the jig can be positioned correctly and re-routed.
■ The recess is too small.	Dimensions have been marked incorrectly. Jig has not been located correctly. Wrong cutter and/or guide bush has been used.	Check measurements have been marked correctly, that jig is lined up correctly and that correct cutter and guide bush are fitted to the router. Re-cut as necessary.
■ The recess is too large.	Dimensions have been marked incorrectly. Jig has not been located correctly. Wrong cutter and/or guide bush has been used.	Check measurements have been marked correct, that jig is lined up correctly and that correct cutter and guide bush are fitted to the router. Re-cut as necessary.
■ Jig slipping on material.	Clamps are not secure or too deep a cut is being made or cutter is blunt.	Check clamps for wear. Clamp securely, take shallow passes, use a sharp cutter.

**BS/JIG SPARE PARTS DIAGRAM**

v1.1 06/2016

Please use only Trend original spare parts.

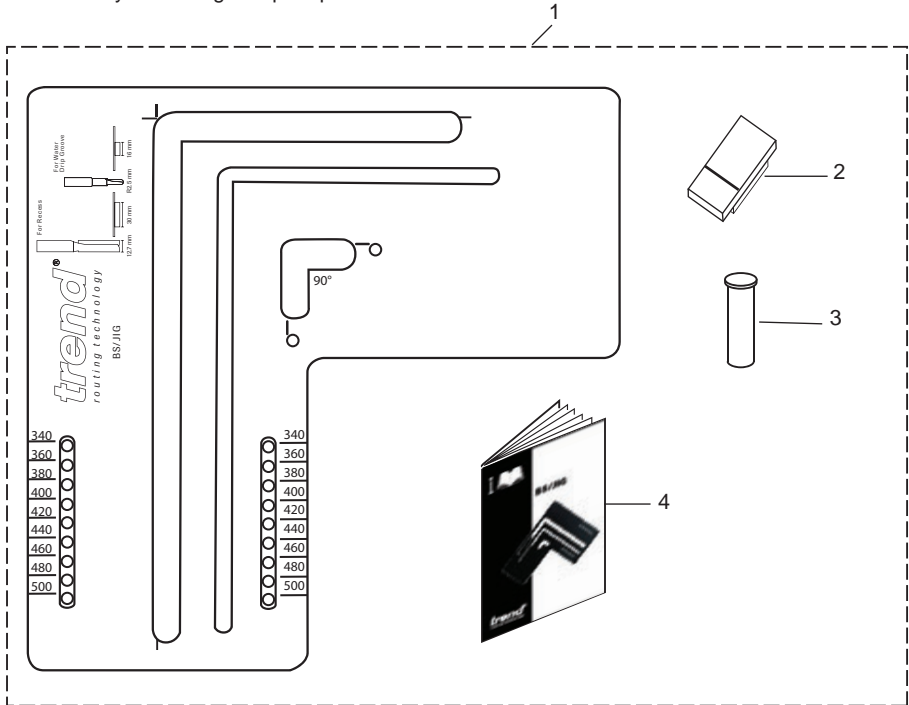

<b>BS/JIG - SPARE PARTS LIST</b>			<b>v1.1 06/2016</b>
<b>No.</b>	<b>Qty.</b>	<b>Desc.</b>	<b>Ref.</b>
1	1	Belfast Sink Jig	BS/JIG
2	1	Sliding Datum Block	WP-BS/01
3	1	BSJ/PIN/4 (Pack of Four)	BSJ/PIN/4
4	1	Manual	MANU/BS

MANU/BS v2.1



RECYCLABLE

**Trend Machinery & Cutting Tools Ltd.**

Odhams Trading Estate St Albans Road  
Watford WD24 7TR England

Tel: 0044(0)1923 249911  
technical@trendm.co.uk

[www.trend-uk.com](http://www.trend-uk.com)



# BS/JIG



***trend***<sup>®</sup>  
routing technology



Please read these instructions before use.