

SEALEY

5 LEVEL RACKING UNITS 340KG/220KG CAPACITY PER LEVEL MODEL NO'S: AP900R/AP1200R

Thank you for purchasing a Sealey product. Manufactured to a high standard, this product will, if used according to these instructions, and properly maintained, give you years of trouble free performance.

IMPORTANT: PLEASE READ THESE INSTRUCTIONS CAREFULLY. NOTE THE SAFE OPERATIONAL REQUIREMENTS, WARNINGS & CAUTIONS. USE THE PRODUCT CORRECTLY AND WITH CARE FOR THE PURPOSE FOR WHICH IT IS INTENDED. FAILURE TO DO SO MAY CAUSE DAMAGE AND/OR PERSONAL INJURY AND WILL INVALIDATE THE WARRANTY. KEEP THESE INSTRUCTIONS SAFE FOR FUTURE USE.



Refer to
instruction
manual



Wear protective
gloves

1. SAFETY

- WARNING!** Ensure Health & Safety, and local authority regulations are adhered to when assembling and using these shelves.
- Locate shelves in a suitable area where they will not be an obstruction.
- Keep the general area clean, uncluttered and ensure there is adequate lighting.
- WARNING!** Erect shelves on a level and solid surface such as concrete.
- Keep children and unauthorised persons away from the storage area.
- DO NOT** use the shelves for any purpose other than that for which they are designed.
- DO NOT** site the shelves out of doors.
- DO NOT** get the shelves wet or use in damp or wet locations or areas where there is condensation.
- DO NOT** clean the shelf supports with any solvents which may damage the coated surface.
- Ensure that the shelves are properly assembled before loading them with any items.
- Where possible the unit should be fixed to the wall with suitable fixings
- Place heavier items on the lower shelves.
- Where possible heavier items should be evenly distributed across the shelves.

2. INTRODUCTION

Fully painted steel frame with five chipboard shelves. 340/220kg capacity per level giving a maximum capacity of 1700kg/1100kg per rack depending on model. Boltless design means no tools required to assemble. Slots together in minutes. Two piece uprights allow use as a single bay rack or split into two separate shelf systems or workstations.

3. SPECIFICATION

Model no.	AP900R	AP1200R
Overall size W x D x H	915 x 460 x 1830mm	1220 x 460 x 1830mm
Capacity	1700kg	1100kg
Shelf capacity	340kg	220kg
Nett weight	23.3kg	33.66kg

fig.1

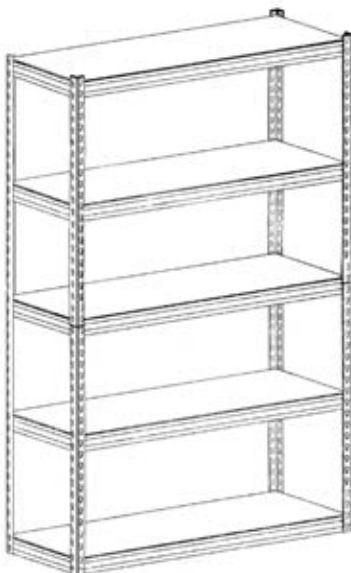
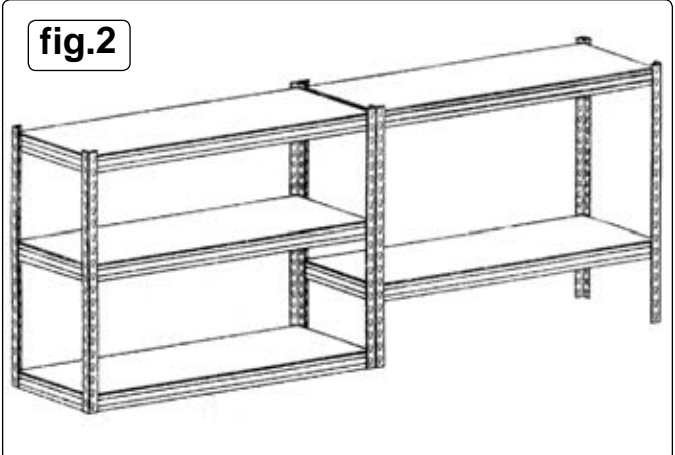
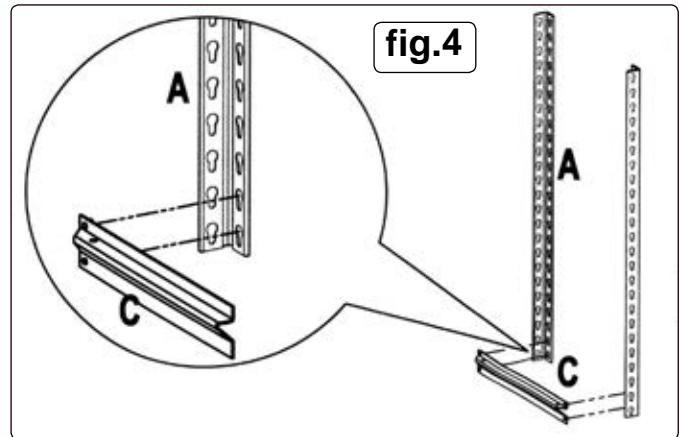
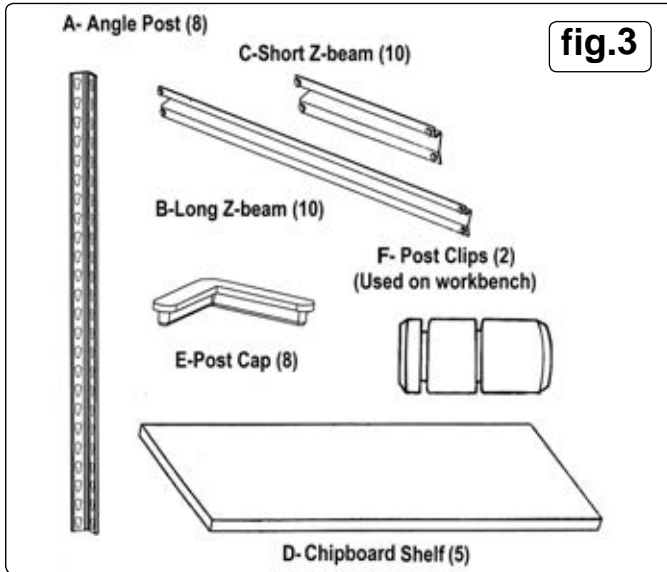

fig.2



4. CONTENTS

- 4.1. Carefully unpack the product and check the contents against fig.3. Should any items be damaged or missing contact your Sealey stockist.



5. ASSEMBLY

- 5.1. **Fig.4**
Support two upright angle posts (A) in a vertical position ensuring that the keyhole slots are pointing downwards. Join them together at the base using a short 'Z' beam (C) ensuring that the shelf support is facing upwards. Tap the beam at either end, close to each angle post to ensure that the rivets are seated at the bottom of the keyhole slots.

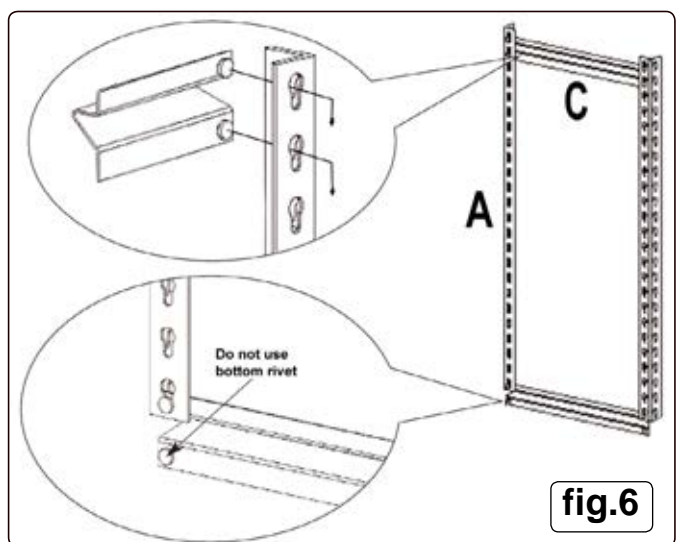
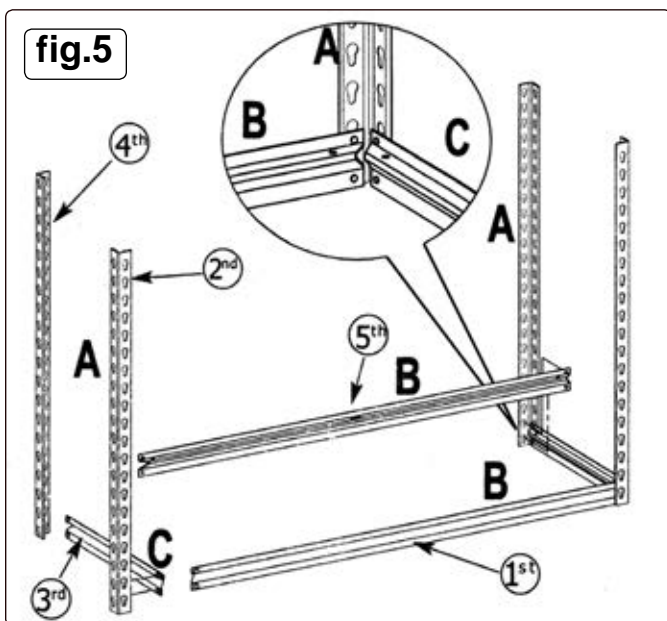

- 5.2. **Fig.5**
Continue to assemble the complete bottom frame in the order indicated above in fig.5 starting with a long 'Z' beam (B). Ensure that each 'Z' beam is facing upwards. Tap the beam at either end, close to each angle post to ensure that the rivets are seated at the bottom of the keyhole slots.

- 5.3. **Fig.6**
Now make up an upper end frame by connecting two angle posts together at the top with a short 'Z' beam (C). Tap the beam at either end to ensure that the rivets are properly seated at the bottom of the keyhole slots. Take a second short 'Z' beam and insert the top rivets into the bottom keyholes. **Only use the top rivets, the bottom rivets will be used to join the bottom and upper frames.** Make up a second upper end frame using the remaining two angle posts and a two short 'Z' beams.

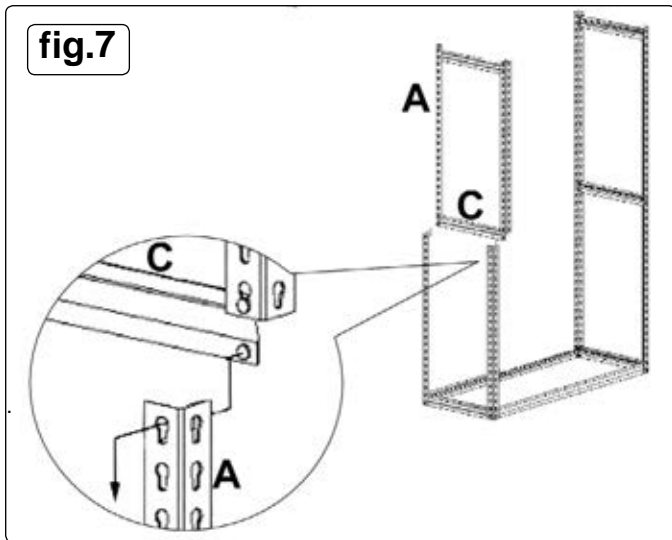

5.4. **Fig.7**
Join the upper and bottom end frames together using the open rivets on the short 'Z' beam (C) see detail in fig.7.

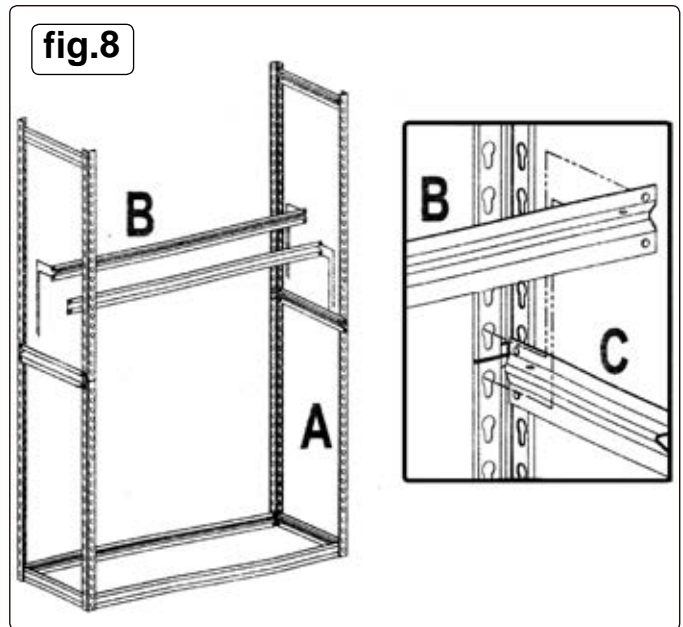

5.5. **Fig.8**
Stabilise the frame assembly by inserting a shelf support halfway up the frame. As each 'Z' beam is added ensure that the top rivets are inserted into the bottom keyholes of the upper frame and the lower rivets are inserted into the top keyholes of the bottom frame as shown below. Tap the beams at either end to ensure that the rivets are properly seated into the keyholes.

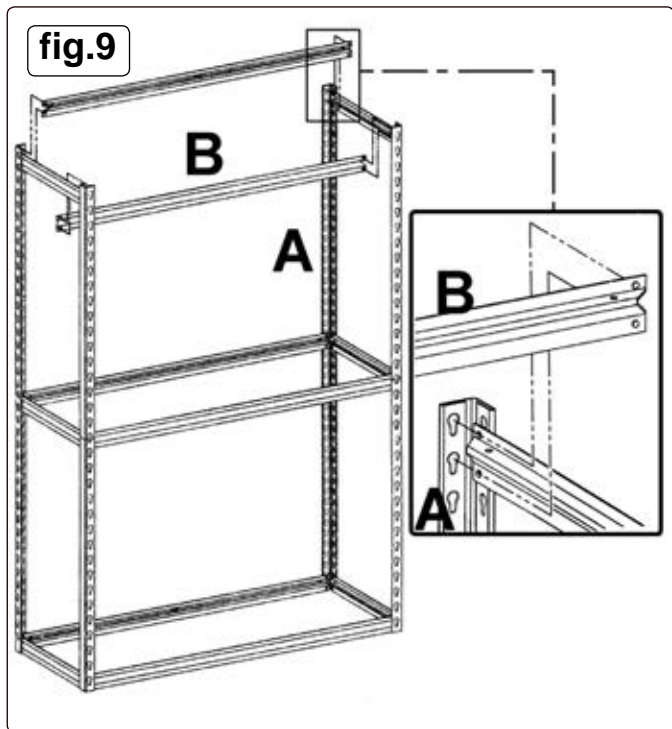

5.6. **Fig.9**
Now stabilise the top part of the frame by adding two long 'Z' beams (B) to make a shelf support at the top of the frame as shown in fig.9. Ensure that the beams are the right way up with the shelf support at the top. Tap the beams at either end to ensure that the rivets are properly seated into the keyholes.

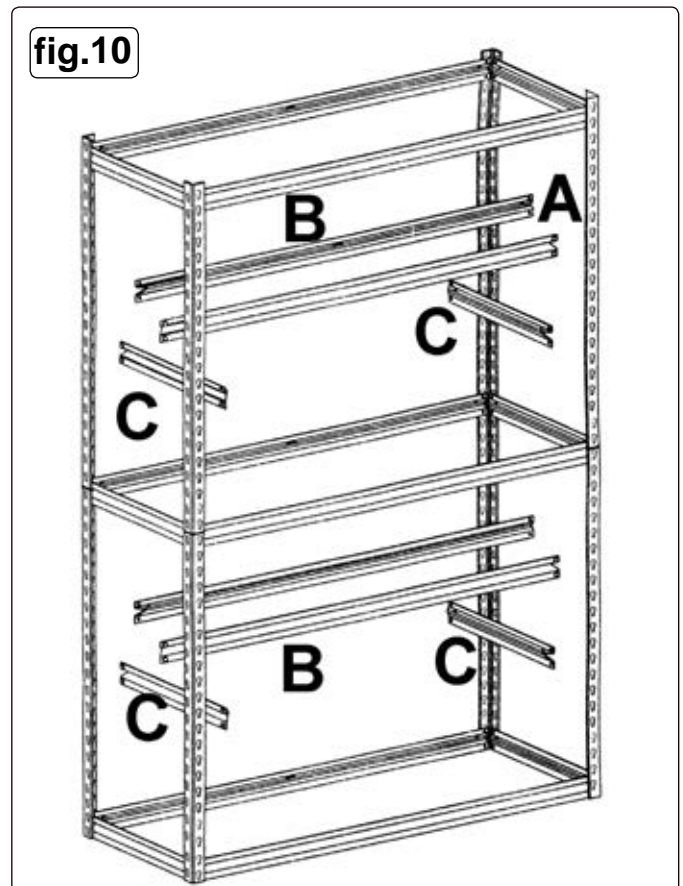

5.7. **Fig.10**
Build one shelf support in the top half of the frame and one shelf support in the bottom half of the frame at the heights required. (The keyholes allow adjustment in 38mm/1¹/₂" increments). Ensure that the beams are the right way up with the shelf support at the top. Tap the beams at either end to ensure that the rivets are properly seated into the keyholes.

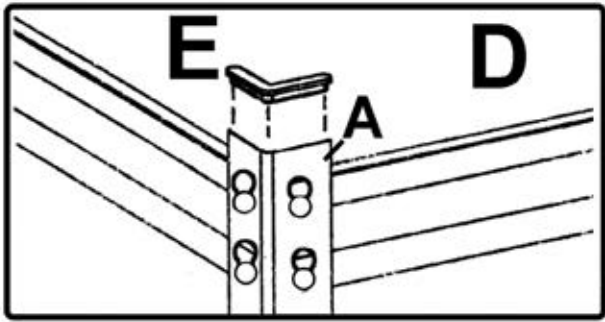

fig.11

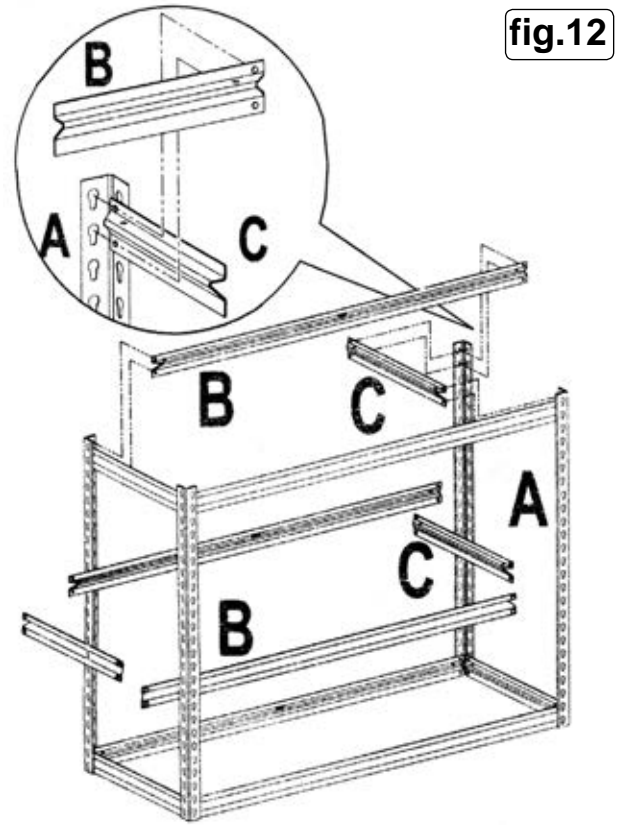
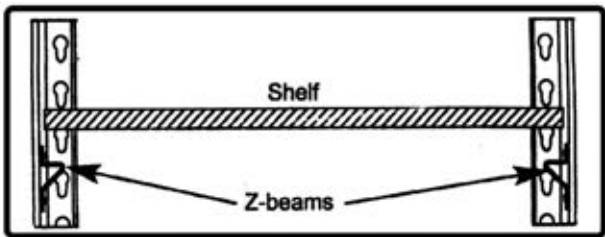
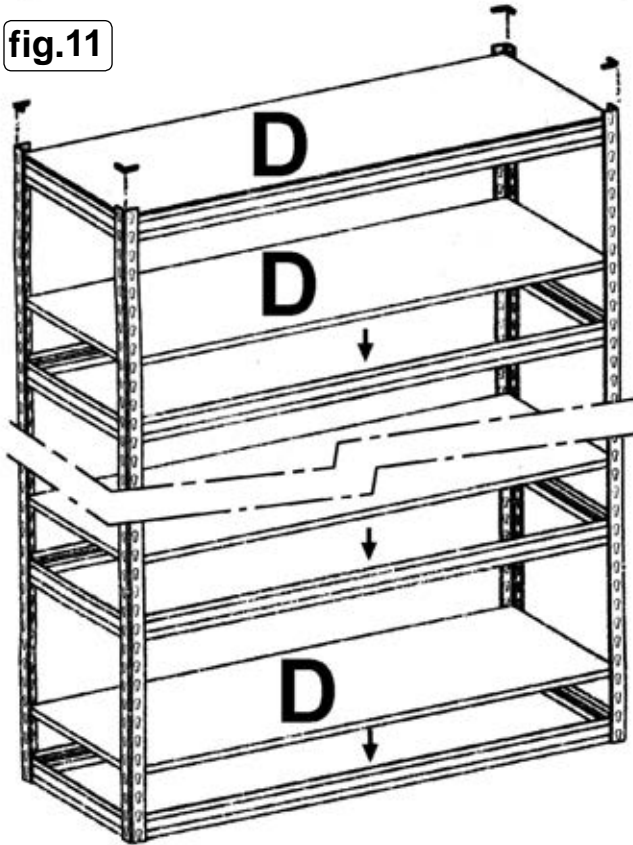

fig.12

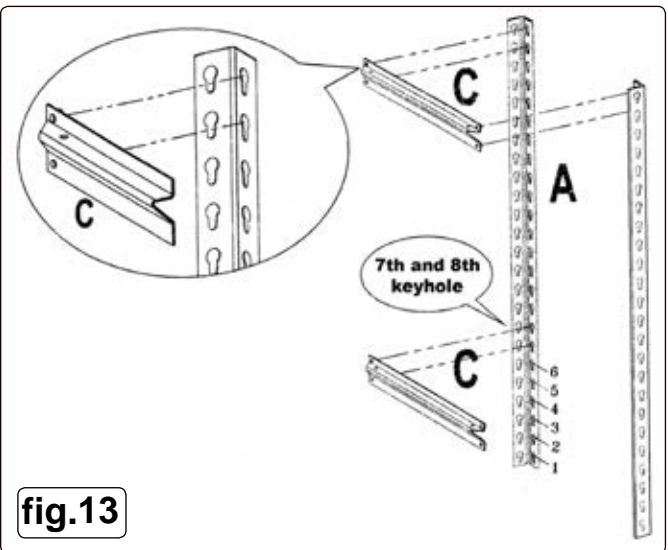

fig.13

5.8. **Fig.11**
Insert a post cap (E) into the top of each angle post 'A' as shown above. Lay a shelf 'D' in between the 'Z' beams at each level created (see lower detail in fig.12.)

5.9. **HALF HEIGHT STORAGE STATION See Fig.12**

Follow steps for Fig.4 and Fig.5 to create a bottom frame with four 'A' posts attached. Using two long 'Z' beams (B) and two short 'Z' beams (C) insert a shelf support level at the top of the angle posts (A). Tap the beams at either end, close to each angle post to ensure that the rivets are seated at the bottom of the keyhole slots. Insert another shelf support level at the desired height within the frame using additional long and short 'Z' beams and ensure that the rivets are seated at the bottom of the keyhole slots.

5.10. **Fig.13**

Now start to build the second low level unit by making up two end frames as shown in Fig.14. One short 'Z' beam (C) should be fixed at the top of the angle posts and the other short 'Z' beam (C) should be fixed at the 7th and 8th keyholes up from the bottom of the angle posts as shown below. Ensure that each 'Z' beam is facing upwards. Tap the beam at either end, close to each angle post to ensure that the rivets are seated at the bottom of the keyhole slots.

fig.14

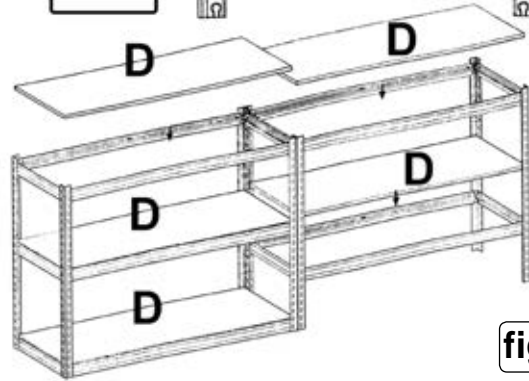
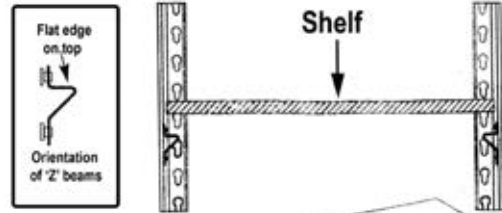
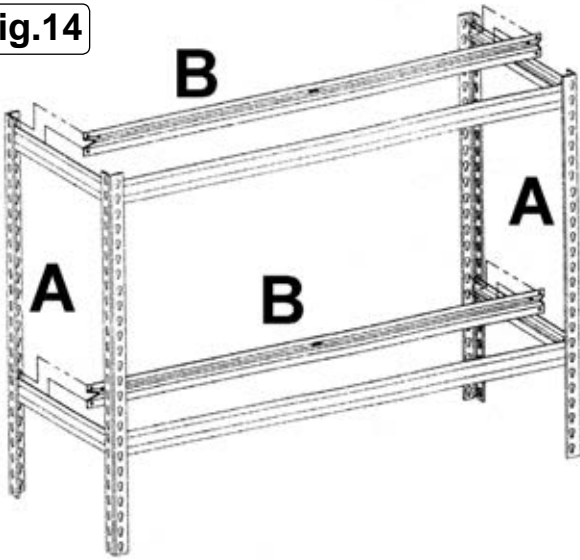

fig.15

- 5.11. **Fig.14**
Join the two end frames together using the four remaining long 'Z' beams as shown above. Ensure that each 'Z' beam is facing upwards. Tap the beams at either end, close to each angle post to ensure that the rivets are seated at the bottom of the keyhole slots.
- 5.12. **Fig.15**
Lay the shelves into position between the 'Z' beams as shown above.
- 5.13. **Fig.16**
Place the two units end to end as shown below and join them together using 2 post clips (F). Insert a post cap (E) into the top of each 'A' post.

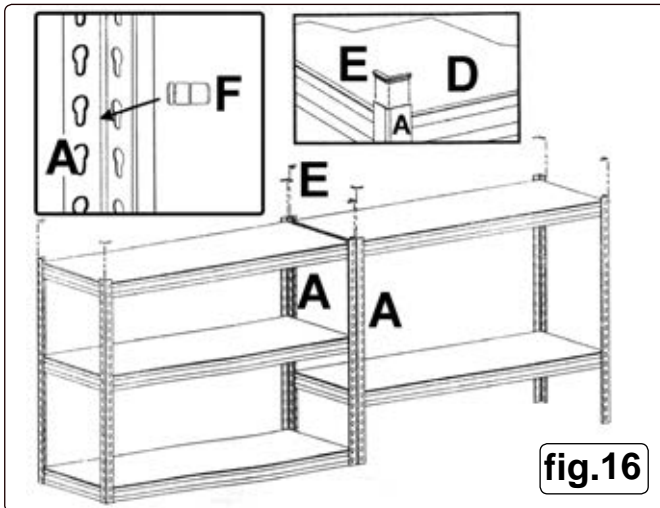

fig.16

Parts support is available for this product. Please email sales@sealey.co.uk or telephone 01284 757500



ENVIRONMENT PROTECTION

Recycle unwanted materials instead of disposing of them as waste. All tools, accessories and packaging should be sorted, taken to a recycling centre and disposed of in a manner which is compatible with the environment. When the product becomes completely unserviceable and requires disposal, drain any fluids (if applicable) into approved containers and dispose of the product and fluids according to local regulations.

Note: It is our policy to continually improve products and as such we reserve the right to alter data, specifications and component parts without prior notice.

Important: No Liability is accepted for incorrect use of this product.

Warranty: Guarantee is 12 months from purchase date, proof of which is required for any claim.

Sealey Group, Kempson Way, Suffolk Business Park, Bury St Edmunds, Suffolk. IP32 7AR



01284 757500



01284 703534



sales@sealey.co.uk



www.sealey.co.uk