



INSTRUCTIONS FOR  
**INDUSTRIAL CABINET 3 SHELF 900MM**  
 MODEL NO: **APICCOMBOH2**

Thank you for purchasing a Sealey product. Manufactured to a high standard, this product will, if used according to these instructions, and properly maintained, give you years of trouble free performance.

**IMPORTANT:** PLEASE READ THESE INSTRUCTIONS CAREFULLY. NOTE THE SAFE OPERATIONAL REQUIREMENTS, WARNINGS & CAUTIONS. USE THE PRODUCT CORRECTLY AND WITH CARE FOR THE PURPOSE FOR WHICH IT IS INTENDED. FAILURE TO DO SO MAY CAUSE DAMAGE AND/OR PERSONAL INJURY AND WILL INVALIDATE THE WARRANTY. KEEP THESE INSTRUCTIONS SAFE FOR FUTURE USE.



Refer to  
 instruction  
 manual

### 1. SAFETY

- WARNING!** Ensure Health & Safety, local authority, and general workshop practice regulations are adhered to when using this cabinet.
- ✓ Locate cabinet in a suitable work area.
- ✓ Keep the work area clean, uncluttered and ensure there is adequate lighting.
- WARNING!** Use cabinet on level and solid ground, preferably concrete.
- ✓ Keep the cabinet clean and tidy in accordance with good workshop practice.
- ✓ Keep children and unauthorised persons away from the work area.
- \* **DO NOT** use the cabinet for any purpose other than that for which it is designed.
- \* **DO NOT** use the cabinet outdoors.
- \* **DO NOT** place the cabinet in a damp or wet location or an area where there is condensation.
- \* **DO NOT** clean the cabinet with any solvents which may damage the surfaces or the protective coating.
- \* **DO NOT** move the cabinet when there are items placed inside.
- \* **DO NOT** overload the cabinet.

### 2. INTRODUCTION

Industrial quality, double door, freestanding cabinets with three shelves. Easily assembled with minimal tool use. Durable scuff resistant, adjustable shelving each with a weight limit of 150kg. Drawers run on heavy duty ball bearing slides each with a weight limit of 75kg, fitted with safety locking catches preventing inadvertant opening. Reinforced steel doors with zinc plated locking bars, provide 3 point locking. Supplied with two coded keys. Ideal for home, office, garage or workshop use.

### 3. SPECIFICATION

**Model no:** .....APICCOMBOH2  
 Width x Depth x Height  
 Overall size: ..... 900 x 450 x 900mm  
 Shelf size (x4): ..... 840 x 380 x 30mm  
 Internal cabinet overall size: ... 850 x 420 x 810mm

### 4. CABINET CONTENTS

Unpack the contents of the boxes and check against the parts lists/diagrams. If there are any parts missing, contact your local Sealey dealer.

Part No.	Part Name	No. of
A1	Rear Panel	1
A2	Rear Panel	1
B1	Left Side Panel	1
B2	Right Side Panel	1
C1	Left Door	1
C2	Right Door	1
D	Top	1
E	Bottom	1
F	Inner Face Plate	1
G	Outer Face Plate	1
J	Plastic Stop	4
K	Locking Pin Locator	2
L	Hinge Pin Locator	4
M	Screw	18
N	Hinge Pin	4

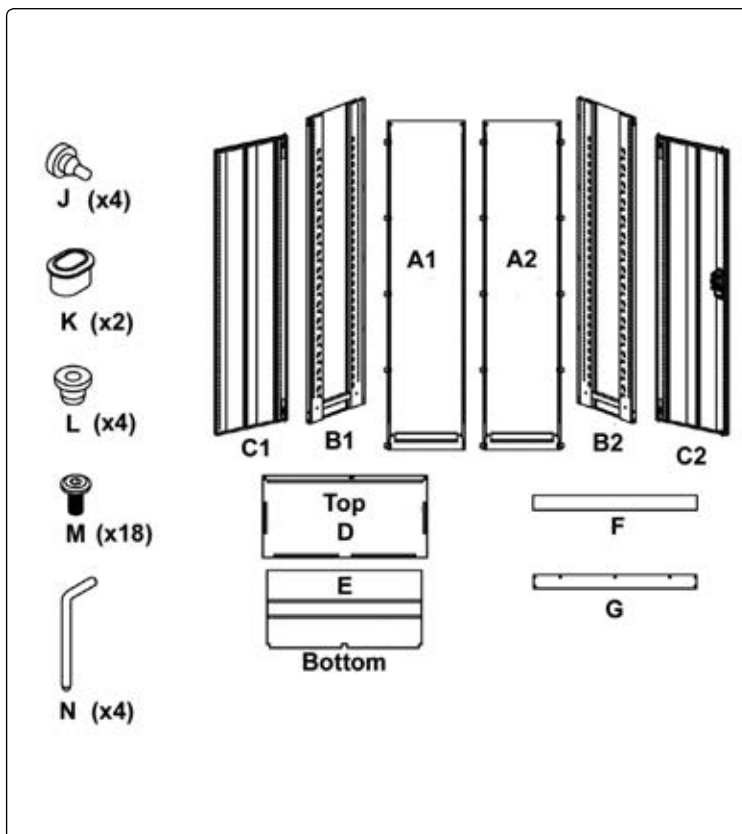

## 5. CABINET ASSEMBLY

5.1. Assemble the cabinet following the numbered sequence below, referencing the parts list and diagram overleaf. Use a trestle table or a workbench if required.

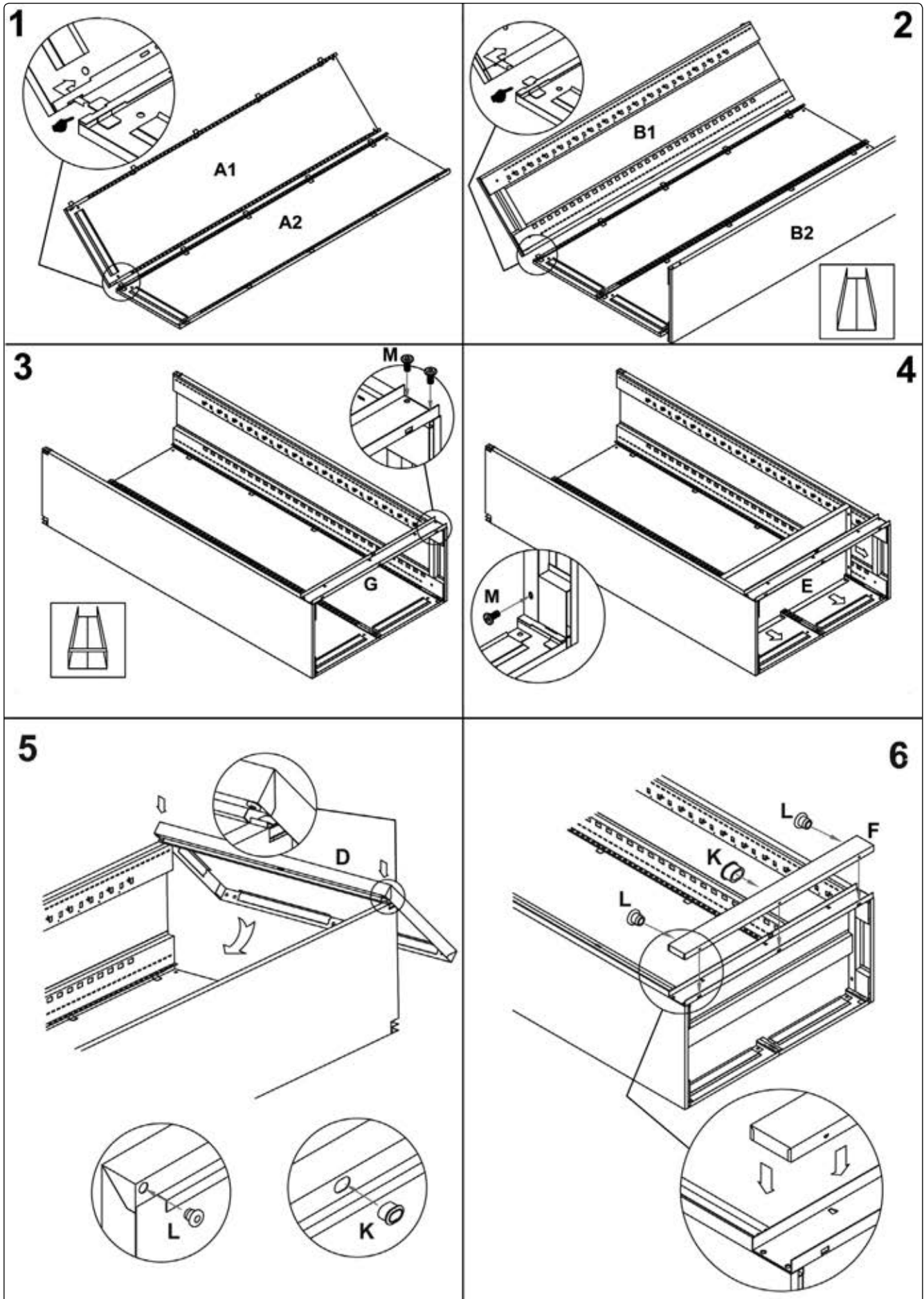

7

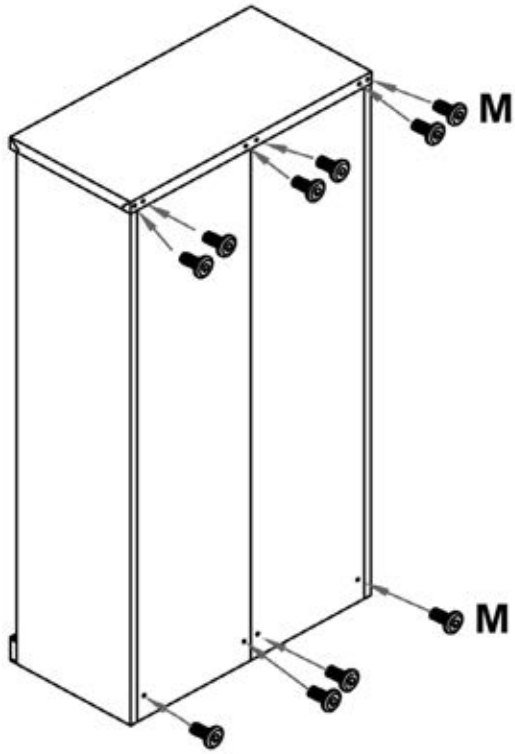

8

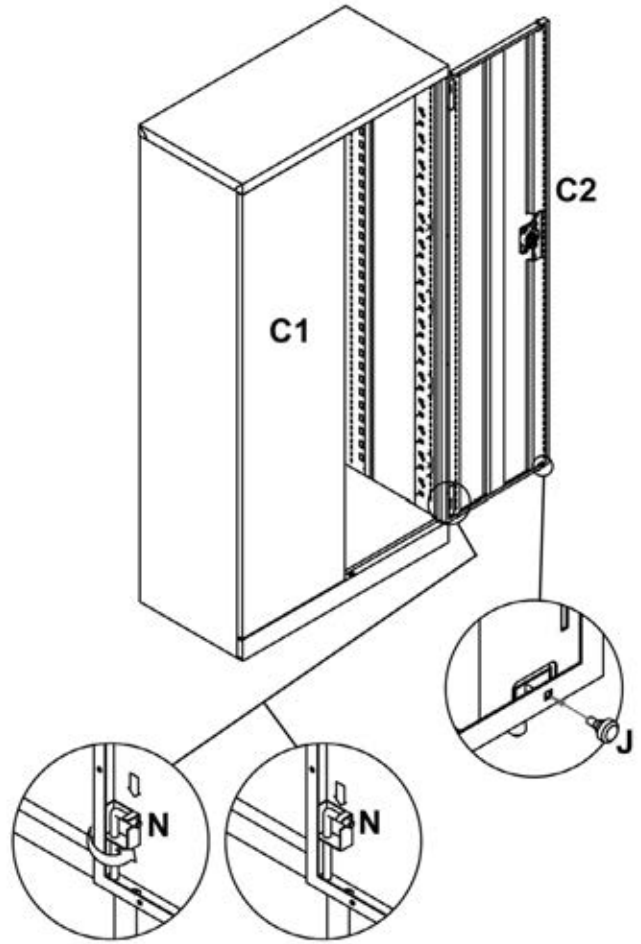

## 6. SHELVES CONTENTS/ASSEMBLY

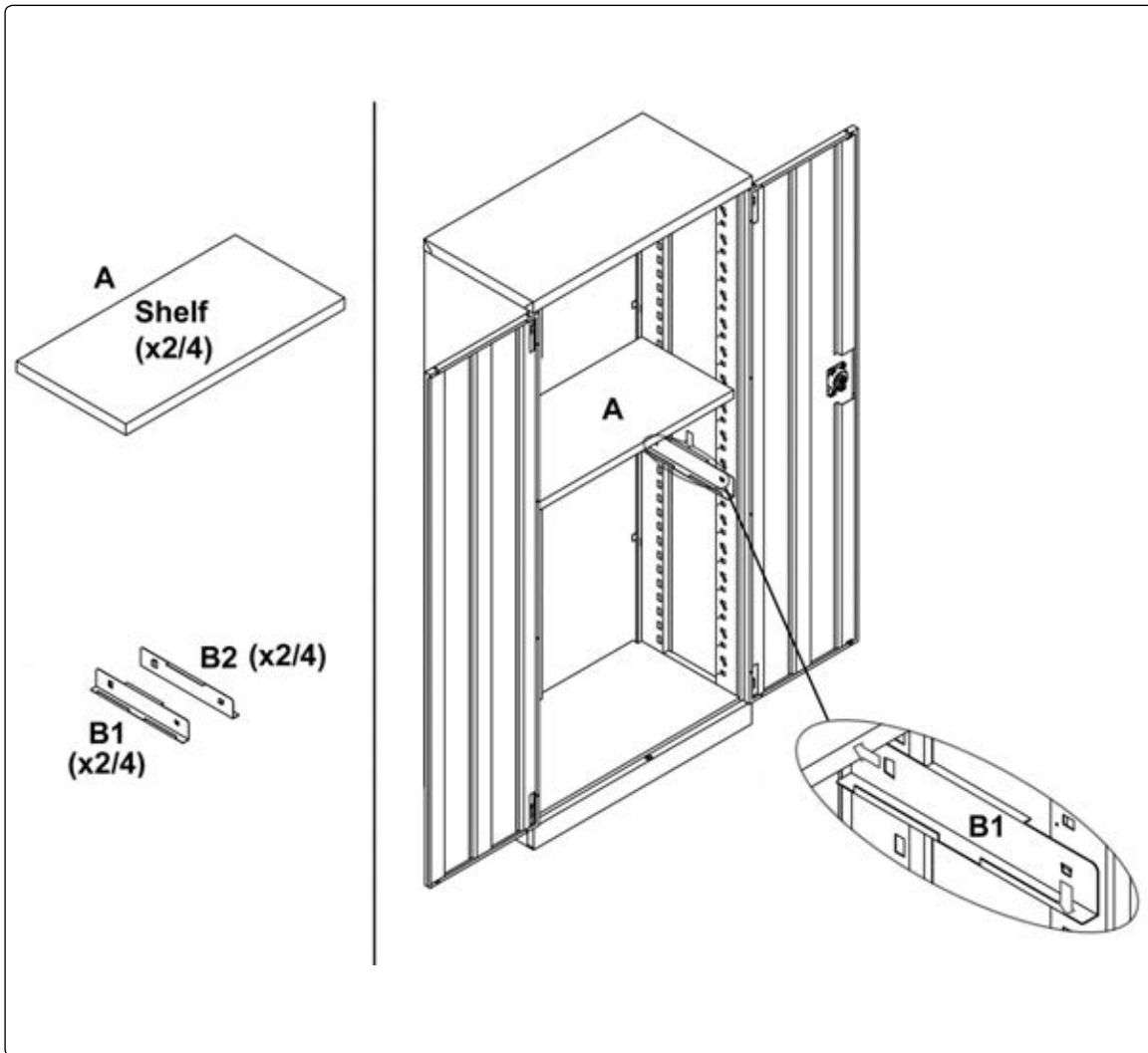

### Environmental Protection

Recycle unwanted materials instead of disposing of them as waste. All tools, accessories and packaging should be sorted, taken to a recycling centre and disposed of in a manner which is compatible with the environment. When the product becomes completely unserviceable and requires disposal, drain off any fluids (if applicable) into approved containers and dispose of the product and the fluids according to local regulations.

**NOTE:** It is our policy to continually improve products and as such we reserve the right to alter data, specifications and component parts without prior notice.

**IMPORTANT:** No liability is accepted for incorrect use of this product.

**WARRANTY:** Guarantee is 12 months from purchase date, proof of which will be required for any claim.



Sole UK Distributor, Sealey Group.  
Kempson Way, Suffolk Business Park,  
Bury St. Edmunds, Suffolk.  
IP32 7AR



01284 757500



01284 703534



[www.sealey.co.uk](http://www.sealey.co.uk)



[sales@sealey.co.uk](mailto:sales@sealey.co.uk)