



INSTRUCTIONS FOR

CORNER RACKING UNIT 5 LEVEL 150KG CAPACITY PER LEVEL

MODEL NO: **AP7150C**

Thank you for purchasing a Sealey product. Manufactured to a high standard, this product will, if used according to these instructions, and properly maintained, give you years of trouble free performance.

IMPORTANT: PLEASE READ THESE INSTRUCTIONS CAREFULLY. NOTE THE SAFE OPERATIONAL REQUIREMENTS, WARNINGS & CAUTIONS. USE THE PRODUCT CORRECTLY AND WITH CARE FOR THE PURPOSE FOR WHICH IT IS INTENDED. FAILURE TO DO SO MAY CAUSE DAMAGE AND/OR PERSONAL INJURY AND WILL INVALIDATE THE WARRANTY. KEEP THESE INSTRUCTIONS SAFE FOR FUTURE USE.



Refer to instructions



Wear protective gloves



Wear eye protection

1. SAFETY

1.1. GENERAL

- WARNING!** Ensure Health & Safety, local authority, and general workshop practice regulations are adhered to when using this racking unit.
- ✓ Locate racking unit in a suitable work area.
- ✓ Keep the work area clean, uncluttered and ensure there is adequate lighting.
- WARNING!** Use racking unit on level and solid ground, preferably concrete.
- ✓ Keep the racking unit clean and tidy in accordance with good workshop practice.
- ✓ Keep children and unauthorised persons away from the work area.
- ✗ **DO NOT** use the racking unit for any purpose other than that for which it is designed.
- ✗ **DO NOT** use the racking unit outdoors.
- ✗ **DO NOT** place the racking unit in a damp or wet location or an area where there is condensation.
- ✗ **DO NOT** clean the racking unit with any solvents which may damage the surfaces or the protective coating.
- ✗ **DO NOT** move the racking unit when there are items placed on it.
- ✗ **DO NOT** overload the racking unit.

2. INTRODUCTION

Fully painted steel frame with five shelves. Space saving corner unit with 150kg capacity per level giving a maximum capacity of 750kg per rack. Two piece uprights allow use as a single bay rack or split into two separate shelf systems or workstations. Ideal for use in conjunction with Model No. AP7200 racking unit.

3. SPECIFICATION

Model no:AP7150C
Size (W x D x H):.....730 x 730 x 1830mm



4. ASSEMBLY

- 4.1. Assemble the racking unit following the sequence below, referencing the parts list. No tools are required although a mallet is useful for tapping the brackets together.

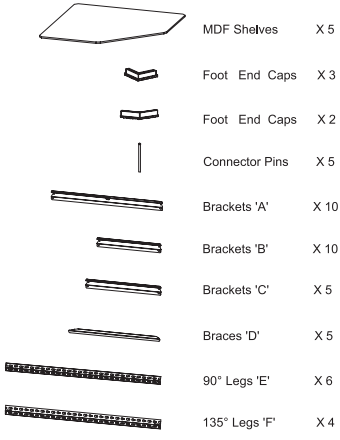
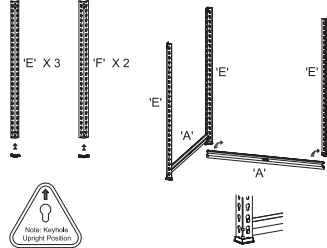
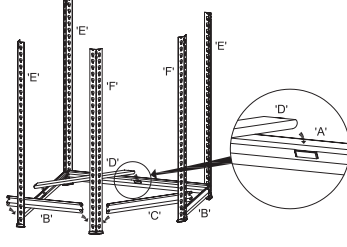
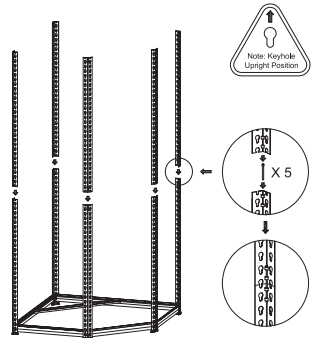
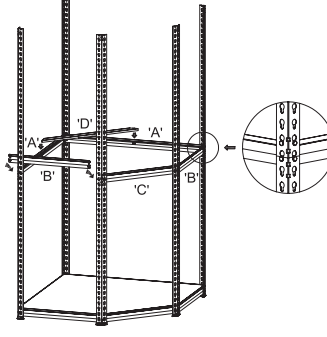
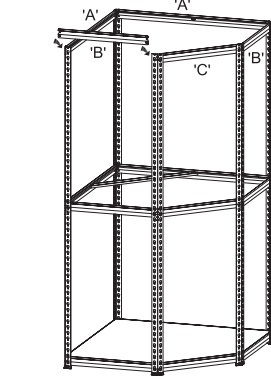
<p>Parts List</p>  <ul style="list-style-type: none"> MDF Shelves X 5 Foot End Caps X 3 Foot End Caps X 2 Connector Pins X 5 Brackets 'A' X 10 Brackets 'B' X 10 Brackets 'C' X 5 Braces 'D' X 5 90° Legs 'E' X 6 135° Legs 'F' X 4 <p>NOT TO SCALE</p>	<p>Step 1</p>  <p>Place footend caps onto the bottom of the 5 legs (E & F). Note upright position. Place shelving brackets (A) onto the legs. A rubber mallet can be used to lightly tap all brackets into the keyholes of the legs. Allow one keyhole free between the footend cap and the shelving bracket.</p>	<p>Step 2</p>  <p>Use two shelf brackets (B) for the side brackets using the shelf bracket from Step 1 as a guide for height, followed by shelf bracket (C) as shown in the diagram. Place brace (D) as shown.</p>
<p>Step 3</p>  <p>Join the upper and lower legs with the connector pins, as shown in the diagram, taking into account upright position. Note: The legs are designed to sit directly on top of each other – don't overlap them. Handy Hint: Flathead screwdriver may be used to tap in connector pins.</p>	<p>Step 4</p>  <p>Fix brackets (A) so that the top rivet sits on the upper legs and the bottom rivets sit on the lower legs. Repeat with brackets (B) and (C), followed by brace (D) as done previously.</p>	<p>Step 5</p>  <p>Fix brackets (A, B & C) at the very top allowing room for the MDF board to sit flush against the legs, followed by brace (D) as done previously.</p>

Step 6

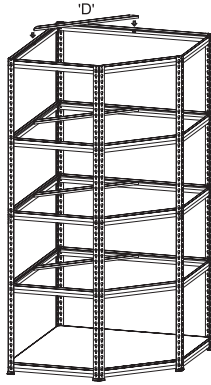

Apply remaining brackets as above to desired height. Ensure that braces (D) are fixed to all shelves.

Step 7

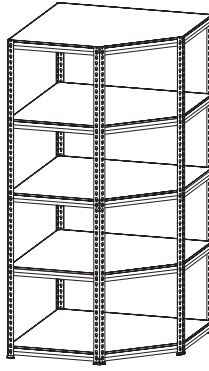

Place the MDF boards in the shelves. Ensure that they are sitting flush against the edge of the shelf brackets.

Environmental Protection



Recycle unwanted materials instead of disposing of them as waste. All tools, accessories and packaging should be sorted, taken to a recycling centre and disposed of in a manner which is compatible with the environment. When the product becomes completely unserviceable and requires disposal, drain off any fluids (if applicable) into approved containers and dispose of the product and the fluids according to local regulations.

Parts support is available for this product. To obtain a parts listing and/or diagram, please log on to www.sealey.co.uk, email sales@sealey.co.uk or telephone 01284 757500.

NOTE: It is our policy to continually improve products and as such we reserve the right to alter data, specifications and component parts without prior notice.

IMPORTANT: No liability is accepted for incorrect use of this product.

WARRANTY: Guarantee is 12 months from purchase date, proof of which will be required for any claim.



Sole UK Distributor, Sealey Group.
Kempson Way, Suffolk Business Park,
Bury St. Edmunds, Suffolk.
IP32 7AR



01284 757500



01284 703534



www.sealey.co.uk



sales@sealey.co.uk