



220BAR PRESSURE WASHER 540L/HR SELF-PRIMING 6.5HP PETROL

MODEL NO: **PWM2500SP.V2**

Thank you for purchasing a Sealey product. Manufactured to a high standard, this product will, if used according to these instructions, and properly maintained, give you years of trouble free performance.

IMPORTANT: PLEASE READ THESE INSTRUCTIONS CAREFULLY. NOTE THE SAFE OPERATIONAL REQUIREMENTS, WARNINGS & CAUTIONS. USE THE PRODUCT CORRECTLY AND WITH CARE FOR THE PURPOSE FOR WHICH IT IS INTENDED. FAILURE TO DO SO MAY CAUSE DAMAGE AND/OR PERSONAL INJURY AND WILL INVALIDATE THE WARRANTY. KEEP THESE INSTRUCTIONS SAFE FOR FUTURE USE.



Refer to instructions



Wear eye protection



Wear ear protection



Wear protective gloves



Wear safety footwear



Wear protective clothing



Hot surfaces



DO NOT direct jet against yourself, other persons, animals, electrical equipment or the machine itself

1. SAFETY

WARNING: The engine is shipped without oil. The pump is shipped without oil. Therefore engine and pump must be filled with the correct type and quantity of oil before use. See section 3 for Oil specifications

1.1. GENERAL SAFETY

- WARNING! RISK OF FLUID INJECTION.** This washer operates at fluid pressures and velocities high enough to penetrate human and animal flesh. If there is an occurrence of fluid injection seek medical help immediately
- WARNING!** Stop the engine and disconnect the mains water supply before changing accessories or performing any maintenance.
- WARNING! DO NOT** operate the washer if damaged. Replace or repair using recommended parts only. Unauthorised parts may be dangerous and will invalidate your warranty. Use authorised Service agent only.
- WARNING! DO NOT** direct jet against yourself or others in order to clean clothes or foot-wear.
- ✓ Keep the washer in good condition. Regular maintenance will give the best and safest performance.
- ✓ Ensure you comply with the water supply company regulations before connecting to the mains. If you are connecting to the mains drinking water supply ensure you have a back flow preventer valve installed.
- ✓ The water supply hose must be reinforced and have an internal diameter of 13mm (1/2"). The minimum water supply rate must be at least equal to the cleaner capacity. The water temperature must not exceed 50°C and the pressure must not exceed 10bar.
- WARNING! DO NOT** operate the washer without the water supply connected. To do so will damage the machine.
- ✓ Position the washer as near as possible to the mains water supply.
- ✓ Only use recommended washing detergents. Failure to do so may cause corrosion to equipment and hoses.
- WARNING!** Use the washer on a flat, level surface, in a horizontal position. Failure to do so will invalidate your warranty.
- ✓ Wear safety goggles and adequate protective clothing and anti-slip rubber soled footwear.
- WARNING!** The high pressure jet must be used with caution. Ensure you aim the lance correctly at the work surface. Failure to do so may scatter loose particles at the same force as the water pressure, resulting in possible damage or personal injury.
- ✓ Keep all persons and animals at a safe distance from the hose working area. It is difficult to give an exact safe distance as it will depend upon your circumstances. We recommend at least 15 metres (16 yards). Also ensure other persons are aware before you start to depress the washer trigger.
- ✓ Hold the gun firmly for it will tend to "kick" backwards when you first pull the trigger.
- ✗ **DO NOT** allow children or untrained persons to operate the washer.
- ✗ **DO NOT** connect other appliances to the washer inlet or outlet. Only use the supplied or recommended outlet nozzle.
- ✗ **DO NOT** use the washer if the water supply hose is damaged. Also check that the hose is laid out straight and safely.
- ✗ **DO NOT** jam the operating trigger in the operating position, and **DO NOT** pull the trigger without holding and aiming the gun correctly.
- WARNING! DO NOT** attempt to alter the pressure regulating valve as this may cause serious damage.
- ✗ **DO NOT** move the washer by pulling on the high pressure hose or the mains water supply hose. Use the machine handle.
- ✗ **DO NOT** direct jet against yourself, other persons or animals, electrical equipment or the machine itself.
- WARNING! DO NOT** leave the engine running for more than 2 minutes without operating the trigger, as temperature/pressure increase may damage the sealing system.
- ✗ **DO NOT** use the washer if you are tired or under the influence of alcohol, drugs or intoxicating medication.
- ✓ Ensure that the hose pressure is discharged before disconnecting the mains water hose.
- ✓ When not in use, disconnect from the water supply. Clean and dry the washer and store in a safe, dry, frost protected, childproof area.
- ✗ **DO NOT** allow the machine to become frozen.

1.2. ENGINE SAFETY

- WARNING!** Check the engine oil level before each start up. Only use an approved oil and never operate the engine with insufficient oil.
- WARNING! DO NOT** touch spark plug or plug lead whilst the engine is running; severe, potentially fatal, electric shock may result.
- ✓ For safety instructions relative to the maintenance and use of the petrol engine refer to the engine instruction manual.
- ✓ Ensure that only the correct fuel type and grade is used.
- ✗ **DO NOT** check ignition system by removing the spark plug or spark plug lead. Use specific tester or contact service agent.
- ✗ **DO NOT** use combustion engine powered machines indoors unless adequate ventilation is assessed by national labour authority.

- ✗ **DO NOT** use the washer with flammable, toxic or corrosive liquids. Use Sealey detergents recommended in section 4.8.7.
 - ✗ **DO NOT** leave the washer unattended whilst operating and **DO NOT** remove the fuel cap whilst the engine is running.
 - ✗ **DO NOT** refuel the engine whilst it is running. Stop the engine and allow it to cool for two minutes before attempting to refuel.
 - ✗ **DO NOT** refuel in a closed or poorly ventilated environment as there is a danger of explosion or fire. Refuel outdoors.
 - ✗ **DO NOT** smoke or place the washer near any naked flames whilst re-fuelling.
 - ✗ **DO NOT** operate washer if there is a fuel leak. Move the unit and avoid using until the leak has been fixed and the machine is dry.
 - ✗ **DO NOT** start the engine if there are any flammable materials near the exhaust system or in the path of the exhaust gases.
 - ✗ **DO NOT** block the engine ventilation grilles.
 - ✓ Ensure engine fuel is stored in an approved container.
 - ✓ For long term storage ensure the fuel is drained and that the washer is adequately protected against frost.
 - ✗ **DO NOT** operate the engine with either the silencer or air filter removed.
 - ✗ **DO NOT** touch the engine during or after use. To avoid burns allow it to cool before handling.
 - ☐ **WARNING!** The warnings referred to in this guide cannot cover all possible conditions and situations that may occur. It must be understood that common sense and caution are factors which cannot be built into this product, but must be applied by the operator.
- NOTE:** This appliance is not intended for use by persons (including children) with reduced physical, sensory or mental capabilities or lack of experience and knowledge, unless they have been given supervision or instruction concerning the use of the appliance by a person responsible for their safety. Children should be supervised to ensure that they **DO NOT** play with the appliance.

2. INTRODUCTION

Petrol powered pressure washer with recoil starting. Ideal for commercial applications with 5m pressure hose, 1m gun and lance and adjustable nozzle. Low-pressure liquid detergent injection system with provision for detergent bottle storage. Safety latch on trigger and automatic low-oil engine shutdown reduce risk of misuse and equipment damage. Unit stands on four legs, two with sucker feet to prevent movement and tilts back onto two pneumatic tyres for moving. Supplied with tools

3. SPECIFICATION

Model No:	PWM2500SP.V2
Engine Capacity:.....	196cc
Engine Power:.....	6.5hp
Engine Type:.....	4-Stroke, Single Cylinder, Petrol
Fuel Consumption:.....	2.1-2.6L/hr
Fuel Tank:.....	4L
Hose Length:.....	5m
Manifold Pressure:.....	175bar(2538psi)
Maximum Inlet Temperature:.....	50°C
Maximum Pressure:.....	220bar(3190psi)
Nozzle:.....	0°, 15°, 25°, 40° Fan & Detergent
Starting:.....	Recoil
Water Flow:.....	540L/hr
Engine Oil (not included).....	SAE10W-30
Pump Oil (not included).....	SAE15W-40



fig.1

4. ASSEMBLY AND PREPARATION

Unpack contents and check to ensure all parts are in good condition. If you experience any problems contact your stockist immediately.

4.1. WHEEL ASSEMBLY FIG.2

NOTE: Make sure that there is enough air in wheel before assembly.

- 4.1.1. Lift the frame (fig.2.A) with one hand and attach one of the wheels (fig.2.B) by pressing the wheel's pin and inserting the wheel shaft into the main frame (fig.2.A). Align the pin with the hole on the frame (fig.2.A) until it snaps in. Repeat it for the opposite side.

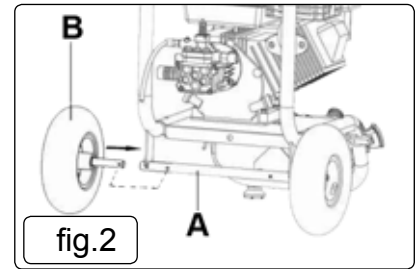

4.2. FRAME ASSEMBLY FIG.3

- 4.2.1. Place the handle assembly flat onto the main frame. Attach handle assembly to frame through square neck bolt. Screw the knob on from outside of the frame. Handles can be folded forward for storage (fig.3)

4.3. HOSE HOOK ASSEMBLY FIG.5

- 4.3.1. Attach the hose hook (fig.5.H) to the back of the panel until it slides into place.

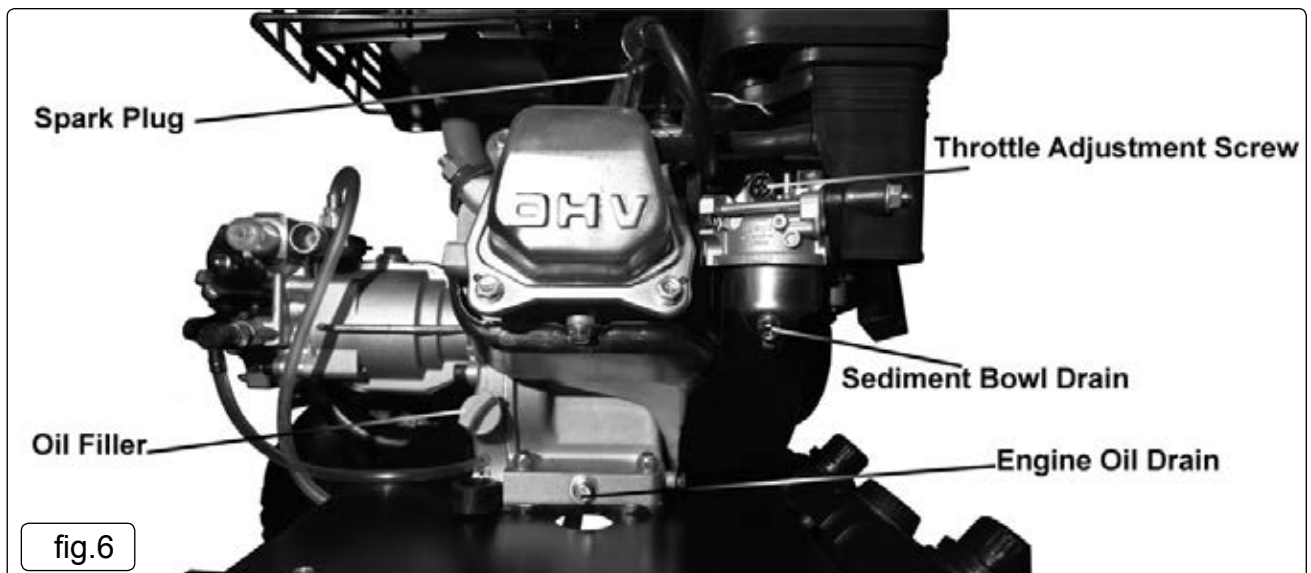
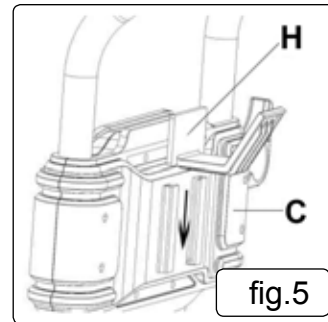
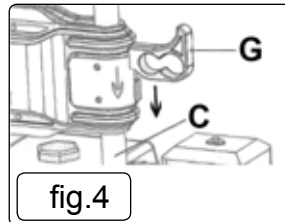

4.4. GUN HOLSTER ASSEMBLY FIG.4

- 4.4.1. Attach the gun holster (fig.4.C.G) to the frame side, slide down into place.

4.5. HOSE CONNECTIONS FIG.7

- 4.5.1. Detach the quick connector from pump water inlet and screw it to a garden hose. Then attach them to the pump water inlet.

4.6. GUN & WAND ASSEMBLY FIG.7

- 4.6.1. Assemble the spray gun with the metal wand. Pull back the rubber piece to expose the threaded fitting. Then, screw the two pieces together and move the rubber piece back.

- 4.6.2. Insert the desired tip to the gun tip connector.

4.7. GUN & HOSE CONNECTIONS FIG.7

- 4.7.1. Take out transit plug from pump outlet. Connect one end of the high pressure hose to pump outlet, and secure the plastic nut. Connect the other end the pressure gun, and fasten the plastic nut.
- 4.7.2. Connect the mains water supply hose to the pump inlet as shown in fig.8.

USE COLD WATER ONLY.

NOTE: The water supply hose must be reinforced and have an internal diameter of 13mm (1/2"). The minimum water supply rate must be at least equal to the washer flow rate.

4.8. WATER SUCTION HOSE

- 4.8.1. Attach suction hose to water inlet on pump.
- 4.8.2. Put the filter inlet into the water supply.
- 4.8.3. Make sure high pressure hose and suction hose are properly connected before starting the pressure washer.

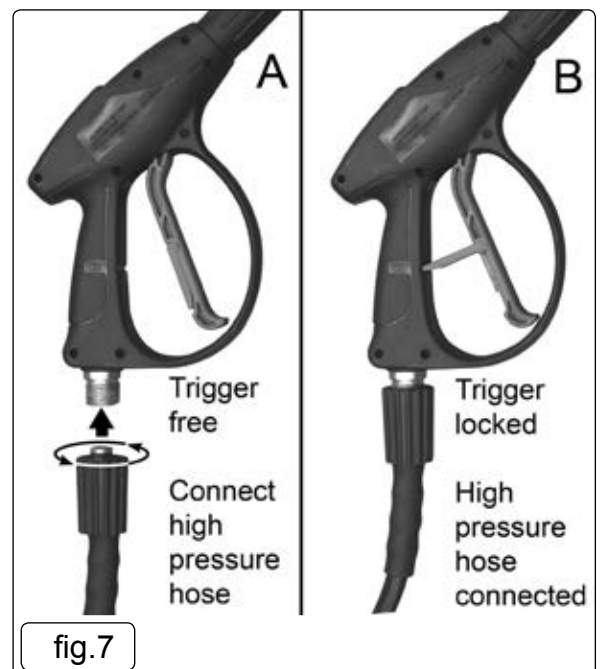

- 4.8.4. The pump will only self prime to a maximum height between pump and surface of supply (suction head) of 1 m. Above this height, the pump will not achieve suction.
- 4.8.5. In case of difficulty in priming the pump, turn the engine off and remove the high pressure hose. With suction filter immersed, restart the engine and run until water emerges from the pump outlet; stop the engine, reconnect the high pressure hose and restart.
- 4.9. USING SPRAY NOZZLE**
- 4.9.1. This pressure washer comes with five different nozzles that can be installed on the metal wand (fig.1).
- 4.9.2. The spray pattern is adjusted by installing the appropriate spray nozzle.
- 4.9.3. 0° (red): Thin and powerful stream of water for difficult stains and debris removal
- 4.9.4. 15° (yellow): Thin-angled spray for detailed cleaning
- 4.9.5. 25° (green): Medium-angled spray for detailed cleaning
- 4.9.6. 40° (white): Large pattern for wider cleaning applications
- 4.9.7. Detergent (black): This nozzle must be used together with a cleaning detergent at a low pressure. Use only this nozzle when using a detergent. Use Sealey Car Shampoo, SCS006 (5ltr). Traffic Film Remover is also available, SCS002 (25ltr) or SCS001 (5ltr).
- 4.9.8. Installing spray nozzle to the quick-connect coupler:
- 4.9.9. Pull the coupler ring back and insert the desired nozzle.
- 4.9.10. Release the coupler ring to lock it back in place.

WARNING!

- a) Avoid sudden bursts of water as this will cause the water pressure to drop and put extreme pressure on the hoses and connections.
- b) If another person is using water from the same supply as the washer, the water pressure will drop. Switch the engine off immediately and wait until the pressure is restored.

4.10. ENGINE LUBRICATION

- 4.10.1. The pressure washer engine is shipped from the factory without oil. **DO NOT** attempt to start the engine before the sump has been filled with the correct amount of oil. Refer to the section 5.7.

4.11. FUEL

- 4.11.1. Fill the petrol tank with fresh unleaded petrol. Keep fuel level on or below the fuel level indicator in the fuel filter which sits in the neck of the tank.

4.12. WATER SUPPLY (COLD WATER ONLY)

- 4.12.1. The unit must be used with cold water supply only. The water hose must be at least ½" (13 mm) in diameter.
- 4.12.2. The water flow rate must not fall below 18 litres per minute (LPM) (4 gallons per minute (GPM)), or the pump might be damaged. The flow rate can be determined by running water for one minute into an empty container.

- 4.12.3. The water supply temperature must not exceed 40°C (104°F).

4.13. ADJUSTING WATER PRESSURE

- 4.13.1. The water pressure can be adjusted using the throttle (fig.9).
- 4.13.2. Move the switch to FAST position to increase the engine speed, thus increasing the water pressure. Move it towards SLOW position to decrease the engine speed, thus decreasing the water pressure.

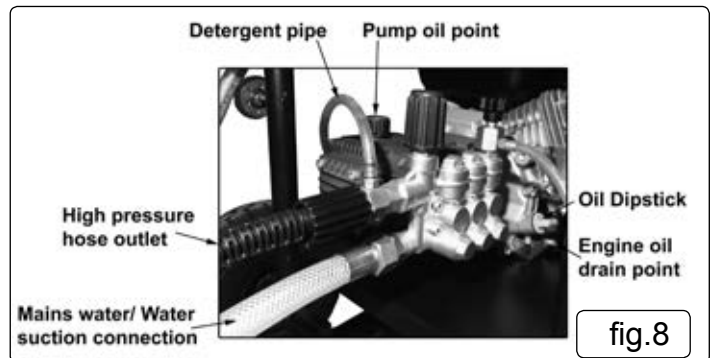

5. OPERATION

- WARNING! THE PRESSURE WASHER ENGINE AND GEARBOX ARE SHIPPED FROM THE FACTORY WITHOUT OIL. FILL BOTH BEFORE FIRST USE.**
- WARNING! RISK OF FLUID INJECTION.** This washer operates at fluid pressures and velocities high enough to penetrate human and animal flesh. If there is an occurrence of fluid injection seek medical help immediately.
- WARNING!** Ensure you read, understand and apply Section 1 safety instructions.
- WARNING!** Dry running can seriously damage the unit.
- WARNING! DO NOT** leave motor running for more than 2 minutes without operating the trigger, as temperature/pressure increase may damage sealing system.

5.1. STARTING PRESSURE WASHER

- 5.1.1. Detach the quick connector from the pump water inlet and screw it to a garden hose. Then attach them to pump water inlet. Attach the other end of the garden hose to a water source.
- 5.1.2. Turn on the water tap. The water flow rate must not fall below 18 litres per minute (4 gallons per minute), or the pump might be damaged.
- 5.1.3. Release the trigger safety lock (fig.7) if it is locked. Purge the air by squeezing the trigger on the gun until there is a steady stream of water.
- 5.1.4. Install appropriate spray nozzle.
- 5.1.5. Start the engine. (→ Section 5.2 Starting Engine)
- 5.1.6. Position the tip of the wand 6-8"(15-20 cm) away from the surface to be cleaned, at an angle appropriate to the spray nozzle used (0°, 15°, 25° or 40°).

5.2. STARTING ENGINE

IMPORTANT Before each use:

- ✓ Check the oil and fuel level and fill if necessary.
- ✓ Make sure that spark plug, muffler, fuel cap, and air filter are in place and secured.
- ✗ **DO NOT** crank engine with spark plug removed.

- 5.2.1. See Section 5.1 Starting Pressure Washer to start the pressure washer.
- 5.2.2. Rotate the engine switch clockwise to the ON position. See fig.10.
- 5.2.3. Fig.9 shows the fuel tap in the OFF position. Push the fuel tap over to the open position.
- 5.2.4. If the engine is cold move the choke lever to the left to close the choke (fig.9).



- 5.2.5. Move the throttle lever left to the fully open position then ease it back slightly.
- 5.2.6. Take hold of the recoil starter handle (see fig.9) and pull it slowly until you feel resistance, then let it return slowly.
- 5.2.7. Now pull the starting handle hard and fast all the way out. Use two hands if necessary.
- 5.2.8. If the engine doesn't start repeat the process from 5.2.2.
- 5.2.9. Once started adjust throttle lever to the required setting and return the choke to the open position when the engine is warm.

5.3. SHUT DOWN PROCEDURE

- 5.3.1. When you have finished cleaning, stop the engine by pushing the throttle lever fully to the right. (See fig.9) and turn the engine switch to the OFF position.
- 5.3.2. Turn off the fuel tap. (See fig.9)
- 5.3.3. In an emergency turn the engine switch to the OFF position.

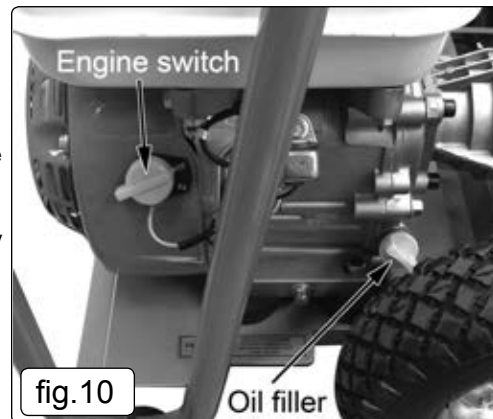

- ❑ **WARNING! DE-PRESSURIZE** After cleaning is completed, turn off the water supply and pull the trigger to de pressurize the unit. Failure to do so might result in personal injury due to discharge of high-pressure water.

5.4. CLEANING WITH DETERGENTS

IMPORTANT This pressure washer is intended for use with special pressure washer detergents only. **DO NOT** use powdered soaps, this will clog the injection system. Follow the detergent manufacturer's directions.

IMPORTANT Working with a detergent ensures quick soaking of the dirt, and allows the high-pressure water to penetrate and remove the dirt more effectively. Always spray detergent on a dry surface, **DO NOT** pre soak the area. Soaking the surface dilutes the detergent and reduces its cleaning ability.

- ❑ **WARNING** Damage may occur to painted surfaces if chemicals (detergents) are allowed to dry on them. Wash and rinse a small section at a time. Avoid working on hot surfaces or under direct sunlight.

- 5.4.1. When using detergent, always use the black detergent nozzle.
 - 5.4.2. When applying detergents, always operate the unit at a low water pressure throttle (fig.9) (set to SLOW position). This provides a gentle application of the detergent, with the water pressure equivalent to a garden hose. Always test the detergent in a concealed area before use.
 - 5.4.3. Pour two types of detergents into separate detergent tanks (fig.1). It is recommended to have one detergent tank filled with all-purpose detergent, and the other filled with a more specific cleaning detergent, depending on the surface to be cleaned.
 - 5.4.4. The liquid detergent will be mixed with water automatically, and discharged through the detergent nozzle at a low pressure.
 - 5.4.5. Use the detergent dial (fig.1) to control the type and amount of detergent used using the scale as reference.
 - 5.4.6. Set the detergent dial to OFF position in order to shut off detergent supply.
 - 5.4.7. Allow detergent to remain on the surface for a short time before rinsing. **DO NOT** allow detergent to dry on the surface.
- ### 5.5. SHUTTING DOWN AND CLEANING UP
- 5.5.1. Skip step 5.5.2 if you are not using detergent.
 - 5.5.2. After cleaning with detergent, fill the detergent tank with clean water. Spray water at a low pressure for one minute, so that all detergent is flushed out of the system.
 - 5.5.3. Stop the engine (→ Section 5.3 Shut Down Procedure).
 - 5.5.4. Turn off the water supply and disconnect the water supply from the water inlet.
 - 5.5.5. Point spray gun in safe direction, push trigger lock, and squeeze spray gun trigger to relieve retained high water pressure. Engage the trigger safety lock (fig.7) on the spray gun.
 - 5.5.6. Disconnect the garden hose from the pump.
 - 5.5.7. Disconnect the pressure hose from the pump and pressure gun for storage. For long-term storage instructions, see section 7.8.
 - 5.5.8. Rewind the pressure hose and attach it to the hose hook.
 - 5.5.9. Disconnect the gun and wand, then insert them into the upper gun holder.
 - 5.5.10. Fold the handle and store.

NOTE: After turning off the machine, wait for 20 minutes to prevent plastic parts from being burned by muffler, then fold the handle.

5.6. TRANSIT.

- 5.6.1. In the upright position the washer stands on four feet and the two wheels are off the ground. The front feet have suckers attached which help to eliminate creep. The rear feet are out of sight between the wheels. To move the unit tip it backwards on the rear feet until the wheels make contact with the ground. Keep the unit well tipped back as you move it.

5.7. ADDING/CHECKING OIL

IMPORTANT Oil has been drained for shipping. Failure to fill engine with oil before starting engine will result in permanent damage and will void engine warranty.

- ❑ **WARNING!** Always check the oil level before starting the engine, making sure the pressure washer is on a level surface.

- 5.7.1. Remove oil tank dipstick (fig.8) and wipe it with a clean cloth.
- 5.7.2. Replace and retighten the dipstick.
- 5.7.3. Remove the dipstick again and check the oil level. It should be at the top of the full indicator on the dipstick.
- 5.7.4. If low, add oil slowly into the oil tank. **DO NOT** overfill. After adding oil, wait one minute and then recheck the oil level.
- 5.7.5. Replace and retighten the dipstick.

NOTE: When adding oil, use oil funnel.

- 5.7.6. Check the pump oil level by removing the pump filler cap (fig.8). The pump should be topped up with 10w-30oil (the oil capacity of the pump is 0.5ltr).

5.8. ADDING FUEL

- ✓ Fill the fuel tank outdoors or in well-ventilated areas.
- ✓ Make sure there is enough fuel in the fuel tank before operating the pressure washer.
- ✓ Use only clean, fresh, unleaded fuel. Use a minimum of 87octane/87 AKI (91 RON).
- ✓ Keep fuel away from sparks, open flames, pilot lights, heat, and other ignition sources.
- ✓ Check fuel hoses, tank, caps, and fittings frequently for cracks or leaks. Replace if necessary.

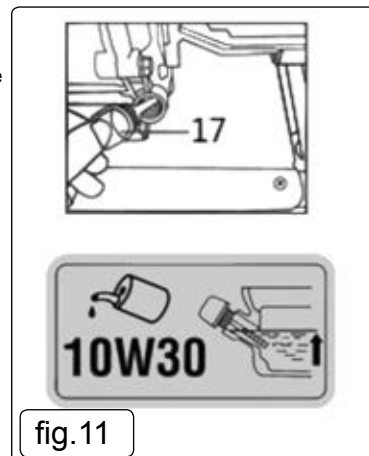

fig.11

- ✓ If fuel spills, wait until it evaporates before starting engine.
- ✗ **DO NOT** use old petrol, and **DO NOT** mix oil with petrol.
- 5.8.1. Stop the engine (→ Section 5.3 Shut Down Procedure) and let it cool at least two minutes before removing the fuel tank cap (fig.1).
- 5.8.2. Clean the fuel cap area of dirt and debris. Remove the fuel tank cap and make sure the fuel filter is in place.
- 5.8.3. Fill the fuel tank (fig.1) with fuel. Never overfill the fuel tank. Fill tank to no more than ½" (13 mm) below the bottom of the filler neck to provide space for expansion caused by the engine heat.
- 5.8.4. Replace the fuel tank cap.

6. MAINTENANCE - WASHER

- **WARNING!** Maintenance should only be performed with the engine turned off and the unit disconnected from the mains water supply.
- 6.1. WINTER STORAGE**
- 6.1.1. Fill the pump with an antifreeze mixture before storing in a frost free, safe, dry area for the winter. Introduce the antifreeze by the following method.
 1. Shut off the water supply and disconnect the supply hose. Relieve pressure within the pump by squeezing the gun trigger. Remove the high pressure hose and let all water drain from it. Hold gun/lance with nozzle downwards and pull trigger until all water has drained out.
 2. Disconnect the ignition lead from the spark plug.
 3. Connect a short length of garden hose to the water inlet and using a funnel pour an antifreeze mixture into it.
 4. Pull the recoil starter several times to circulate the antifreeze through the pump. Continue to add antifreeze and pull the recoil until antifreeze is expelled from the pump.
- 6.2. CLEANING WATER INLET FILTER**
- **WARNING! DO NOT** operate this pressure washer without the water inlet filter in place, as deposits could build up internally and affect the functioning of the unit.
- 6.2.1. This pressure washer is equipped with a water inlet filter.
- 6.2.2. The water inlet filter must be kept clean at all times, otherwise it can restrict the water flow to the pump unit and damage it.
- 6.2.3. Remove the quick-connect coupler from the water inlet, then remove and clean the water inlet filter.

7. MAINTENANCE - ENGINE

- 7.1. Change engine oil after the first 8 hours of operation. After that, it should be replaced every 100 hours or every six months. Change oil more often if engine is operated under heavy load, or in high ambient air temperatures. During normal operation, partially burned fuel, small particles of metal from the cylinder walls, pistons, bearings and combustion deposits will gradually contaminate the oil. If the oil is not changed regularly, these foreign particles can cause increased friction and a grinding action which shortens the life of the engine. Fresh oil also assists in cooling. Old oil gradually becomes thick and loses its cooling ability as well as its lubricating qualities.
- 7.2. CHECKING THE OIL LEVEL.** Ensure the unit is on a level surface.
 - 7.2.1. Unscrew the dipstick and wipe it clean of oil. Note that the maximum oil level should be just below the opening of the filler neck.
 - 7.2.2. Check the oil level by seating the dipstick into the hole without screwing it in. If there is no oil on the dipstick when it is removed the level is too low and should be topped up immediately with an SAE10W - 30 oil.
 - 7.2.3. Top up oil if necessary and recheck level.
 - 7.2.4. Screw dipstick fully home to seal oil fill hole.
- NOTE:** The engine is fitted with a low oil sensor which will automatically shut the engine down in a low oil situation. The sensor may also operate if the unit is not on a level surface.
- 7.3. DRAINING ENGINE OIL**
- 7.3.1. The engine oil should be replaced after the first 8 hours of operation, or after the first month of use. After that, it should be replaced every 100 hours or every six months.
- 7.3.2. To drain the engine oil:
 1. Loosen the oil tank dipstick (fig.8).
 2. Place an oil container underneath the opening on the mainframe.
 3. Remove the hex (fig.6) screw and drain the oil.
 4. Once the oil has been completely drained, retighten the hex screw (fig.6) and oil tank dipstick.
- 7.4. CHECKING AIR FILTER**
- IMPORTANT:** Clean air filter (fig.1) element after every 50 hours of use (every 10 hours under dusty conditions). Wash in high flashpoint solvent, squeeze dry, dip in clean engine oil, and squeeze out excess oil.
 - 7.4.1. To access the air filter element unscrew and remove the wing nut on the top of the cover. Lift the air filter cover off its threaded mounting rod (fig.12).
 - 7.4.2. Remove the foam filter (fig.13) from the air intake base moulding.
 - 7.4.3. Wash the foam element with a household detergent or a high flash-point solvent and squeeze dry. When the element is thoroughly dry soak it in clean engine oil. Squeeze out any excess oil, fit back over the air intake base moulding.
 - 7.4.4. Place the air filter cover onto the threaded rod and secure with the wing nut.
 - 7.4.5. The foam element should be replaced after every 300 hours of service.



fig.12



fig.13

7.5. INSPECTING, REPLACING OR CLEANING THE SPARK PLUG

NOTE: The spark plug should be checked after every 100 hours of operation or every six months.

7.5.1. To replace or clean the spark plug:

1. Disconnect the spark plug wire by pulling it off the spark plug.
2. Using provided spark plug wrench (fig.15.J), remove the spark plug by turning it counter-clockwise. If there is a carbon sediment build-up, remove it. If there is too much carbon sediment, replace the spark plug.
3. Check the gap with a wire gauge. If necessary, reset the gap to 0.7-0.8 mm (fig.14). Install and tighten the spark plug to the recommended torque – 180 lb.-in (20 Nm).
4. Reinstall the spark plug wire and protection cage in reverse order.

NOTE: In some areas, local law requires using a resistor spark plug to suppress ignition signals. If this engine was originally equipped with a resistor spark plug, use the same type for replacement.

7.6. CLEANING THE CARBURETTOR FIG.16

7.6.1. To clean the carburettor:

1. Screw down the bolt on the bottom of carburettor with wrench.
2. Push the float up four to five times, then clean sediment cup with fuel.

NOTE: Put the sediment cup back. Be careful not to miss the O ring.

7.7. CLEANING THE SPRAY TIPS FIG. 17

- **WARNING!** Clogging of the spray tip increases the water pressure and might damage the pump unit.

7.7.1. Clean the spray tip by carefully inserting the provided spray tip cleaner, or a thin, sharp object (e.g., paper clip) into the tip to remove deposits (fig.17).

7.8. PUMP WINTERIZATION AND LONG TERM STORAGE

7.8.1. **STEP 1: ENGINE STORAGE.** If the unit is not to be used for more than one month the following procedure should be followed.

1. Top-up engine oil to maximum.
2. Drain petrol from the fuel tank, fuel line, fuel tap and carburettor.
3. Pour one teaspoon of engine oil through the spark plug hole, pull the recoil starter several times and replace the spark plug. Then pull the starter slowly until an increase in pressure is felt indicating that the piston has commenced its compression stroke and leave it in this position. This closes both the intake and exhaust valves and prevents the inside of the cylinder from rusting.

7.8.2. STEP 2: PROTECT FUEL SYSTEM

FUEL ADDITIVE:

Fuel can become stale when stored for over 30 days. Stale fuel causes acid and gum deposits to form in the fuel system or on essential carburettor parts. Please use fuel stabilizer to keep fuel fresh. Run the engine for 2 minutes to circulate the stabilizer throughout the fuel system before storage.

DRAIN FUEL FIG 6:

If fuel in the engine has not been treated with a fuel stabilizer, it must be drained into an approved container. Run the engine until it stops from lack of fuel. Remove the hex screw from the carburettor then drain the fuel from the tank, carburettor, and tube. Screw the carburettor drain hex screw back once the fuel has been completely drained.

7.8.3. STEP 3: CHANGE OIL

- **WARNING!** Petrol is extremely flammable and potentially explosive. **DO NOT** perform maintenance on petrol associated components where there is any source of ignition present such as cigarettes, sparks, naked flame or hot surfaces.

7.8.4. While engine is still warm, drain oil from crankcase. Remove the hex screw from the crankcase (fig.6). Drain the oil to a container. Refill with recommended grade oil (SAE 10W-30).

IMPORTANT:

- If the pressure washer is to be stored with fuel in the fuel tank and carburettor, it is important to reduce the hazard of fuel vapour ignition.
- Select a well-ventilated storage area away from any appliance that operates with a flame, such as a furnace, water heater, or clothes dryer. Also avoid any area with a spark-producing electric motor, or where power tools are operated.
- If possible, avoid storage areas with high humidity, this will promote rust and corrosion.
- Place the pressure washer on a level surface. Tilting can cause fuel or oil leakage.

7.9. MAINTENANCE SCHEDULE.

7.9.1. Before each use;

Check engine oil level.

Inspect the unit for evidence of oil and fuel leaks.

7.9.2. After the first 8 hours or 20 hours only;

Change the engine oil.

Check pump oil

7.9.3. Every 6 months or 100 hours;

Change the engine oil.

Check pump oil

Inspect and clean air filter.

Clean the deposit cup.

Clean spark plug and check gap.

7.9.4. Every 300 hours;

Replace air cleaner element.

Check valve clearances.

Check idling speed.

Clean spark plug and check gap.

Clean fuel tank fuel filter.

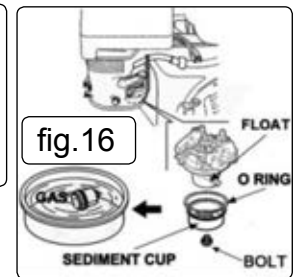
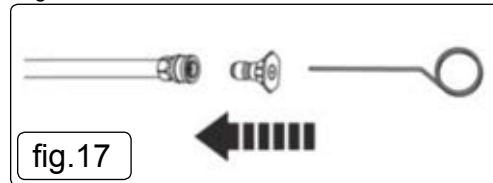
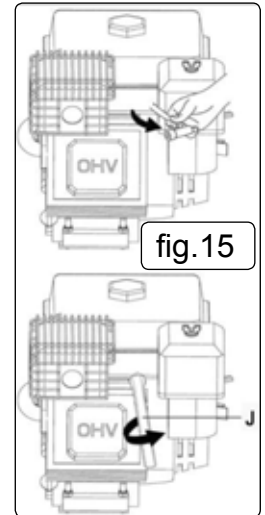
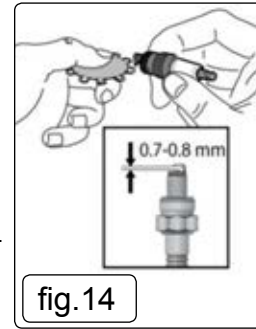

8. TROUBLESHOOTING

PROBLEM		POSSIBLE CAUSE	SOLUTION
Engine	Engine doesn't start or is difficult to start	No fuel	Fill the fuel tank with regular gasoline
		Excess water pressure in pump or hose	Release water pressure by squeezing trigger on gun
		Clogged carburettor	Clean the carburettor. Refer to the instruction manual
		Carbon build-up on spark plug	Clean the spark plug. Refer to the instruction manual
		Incorrect starting method	Use correct starting method. Refer to the instruction manual
	Engine stops after starting	Low oil or no fuel	Check oil and fuel levels
	Engine lacks power	Clogged air filter	Clean or replace the air filter. Refer to the instruction manual
		Clogged carburettor	Clean the carburettor. Refer to the instruction manual
	Carburettor leaks	Carburettor is clogged	Clean the carburettor. Refer to the instruction manual
	Starter rope doesn't recoil	Recoil mechanism is broken	Contact your local Sealey Stockist
Engine sounds abnormal or overloaded	Clogged nozzle	Clean nozzle with tip cleaner	
	Pressure is too high	Contact your local Sealey Stockist	
Pump	No pressure, low pressure	Nozzle tip not attached	Attach required nozzle tip
		Water supply tap closed	Turn on tap. Ensure there are no kinks or blockage in hose
		Water supply pressure is low	Ensure tap is fully opened. Check to make sure water supply is to spec
		Inlet water filter is clogged	Clean the water filter. Refer to the instruction manual
		Air in pump	Squeeze trigger to release the air in pump when the machine is running
		Clogged check valve	Contact your local Sealey Stockist
		Damaged pump	Contact your local Sealey Stockist
	Pressure too high	Clogged nozzle	Clean nozzle with tip cleaner
	Water or oil leaks out of pump	Damaged seal ring	Contact your local Sealey Stockist
	Cold water keeps draining out of thermal relief valve	Defective thermal relief valve	Contact your local Sealey Stockist
Accessories & Connections	No intake of detergent	The detergent siphon tube is not connected	Connect detergent siphon tube properly. Refer to the instruction manual
		Damaged detergent siphon tube	Replace the detergent siphon tube
		Wrong nozzle	Use black nozzle when applying detergent. Refer to the instruction manual
		Detergent adjustment knob set to wrong position	Check adjustment knob. Refer to the instruction manual
		Clogged nozzle	Clean nozzle
		Clogged pump detergent siphon fitting	Detach the detergent siphon tube and clean the fitting with tip cleaner
		Detergent is too thick. Clogged detergent filter	Use only detergent approved for use with pressure washer
	The trigger can't be squeezed	Safety lock is open	Close the safety lock. Refer to the instruction manual
	There is water leakage at joints/connections on gun, hose and/or pump	Damaged seal ring	Change with new O-ring.
	High pressure hose can't be connected to pump or gun	The O rings are not lubricated	Put lubricating oil or water on the O rings



ENVIRONMENT PROTECTION

Recycle unwanted materials instead of disposing of them as waste. All tools, accessories and packaging should be sorted, taken to a recycling centre and disposed of in a manner which is compatible with the environment. When the product becomes completely unserviceable and requires disposal, drain any fluids (if applicable) into approved containers and dispose of the product and fluids according to local regulations.



WASTE ELECTRICAL AND ELECTRONIC EQUIPMENT REGULATIONS (WEEE)

When this product is no longer required, or has reached the end of its useful life, please dispose of it in an environmentally friendly way, in accordance with local waste regulations.

Note: It is our policy to continually improve products and as such we reserve the right to alter data, specifications and component parts without prior notice.

Important: No Liability is accepted for incorrect use of this product.

Warranty: Guarantee is 12 months from purchase date, proof of which is required for any claim.

Sealey Group, Kempson Way, Suffolk Business Park, Bury St Edmunds, Suffolk. IP32 7AR



01284 757500



01284 703534



sales@sealey.co.uk



www.sealey.co.uk