



INSTRUCTIONS FOR

2/3 LEVEL HEAVY DUTY WORKSHOP TROLLEY - HI-VIS GREEN

MODEL NO'S: **CX109HV & CX110HV**

Thank you for purchasing a Sealey product. Manufactured to a high standard, this product will, if used according to these instructions, and properly maintained, give you years of trouble free performance.

IMPORTANT: PLEASE READ THESE INSTRUCTIONS CAREFULLY. NOTE THE SAFE OPERATIONAL REQUIREMENTS, WARNINGS & CAUTIONS. USE THE PRODUCT CORRECTLY AND WITH CARE FOR THE PURPOSE FOR WHICH IT IS INTENDED. FAILURE TO DO SO MAY CAUSE DAMAGE AND/OR PERSONAL INJURY AND WILL INVALIDATE THE WARRANTY. KEEP THESE INSTRUCTIONS SAFE FOR FUTURE USE.



Refer to instructions

1. SAFETY

- ❑ **WARNING!** Ensure Health & Safety, local authority, and general workshop practice regulations are adhered to when using this trolley.
- ✓ Always load evenly with the centre of gravity of the load as near centre of the trolley as possible.
- ✗ **DO NOT** overload the trolley - see specifications.
- ✓ Use the trolley in a suitable work area.
- ✓ Keep the work area clean, uncluttered and ensure there is adequate lighting.
- ✓ Keep the trolley clean and tidy in accordance with good workshop practice.
- ✗ **DO NOT** use the trolley for any purpose other than that for which it is designed.
- ✗ **DO NOT** stand on the trolley, use it as a ladder or allow others to ride on the trolley.
- ✓ Use the wheel locks to prevent the trolley from inadvertently moving.
- ✗ **DO NOT** leave unattended, especially when loaded, unless the wheels are locked, chocked or the trolley otherwise secured.
- ✗ **DO NOT** use trolley on uneven ground and do not run over curbs or steps - use a ramp.
- ✗ **DO NOT** use trolley if any part is significantly damaged, paying particular attention to the wheels.
- ✓ Keep children and unauthorised persons away from the work area.

2. INTRODUCTION

Ideal for regularly used workshop items such as body repair kits, power tools and bulky equipment too big for a traditional tool chest. Features 14 tool holes ideal for keeping small tools on hand. Strong build quality and heavy-duty PU 4" castors, two of which are locking, makes an excellent dismantling trolley for smaller vehicle components.

3. SPECIFICATIONS

Model no's:.....CX109HV, CX110HV
 Overall size (W x D x H):.....835 x 410 x 815mm
 Shelf size (W x D x H):.....785 x 405 x 80mm
 Capacity per level: 80kg
 Total load capacity: 160kg

4. ASSEMBLY

Fig.1

- 4.1. Attach posts to trays.
- 4.1.1. Lay one tray (the one with the four sets of castor holes on the bottom) on the floor and attach posts to the outside corners of the tray using 32 x M6 short bolt and nut sets.

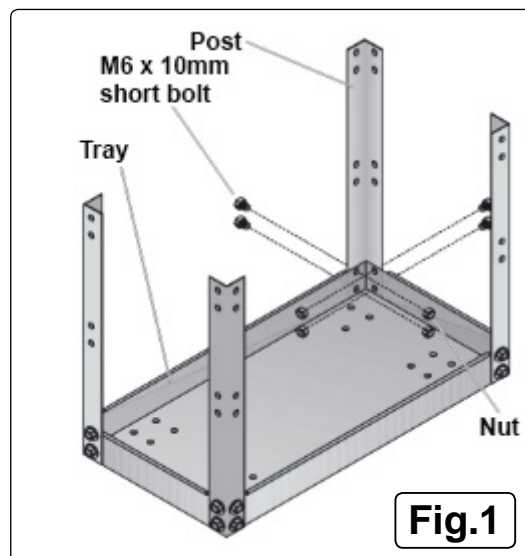

Fig.2

This step is NOT applicable for CX109HV go to fig.3

- 4.2. Attach the other tray to the inside top of the posts using 32 x M6 short bolt and nut sets.
- 4.3. Put the trolley on its side and work on two posts at a time, for ease of assembly.

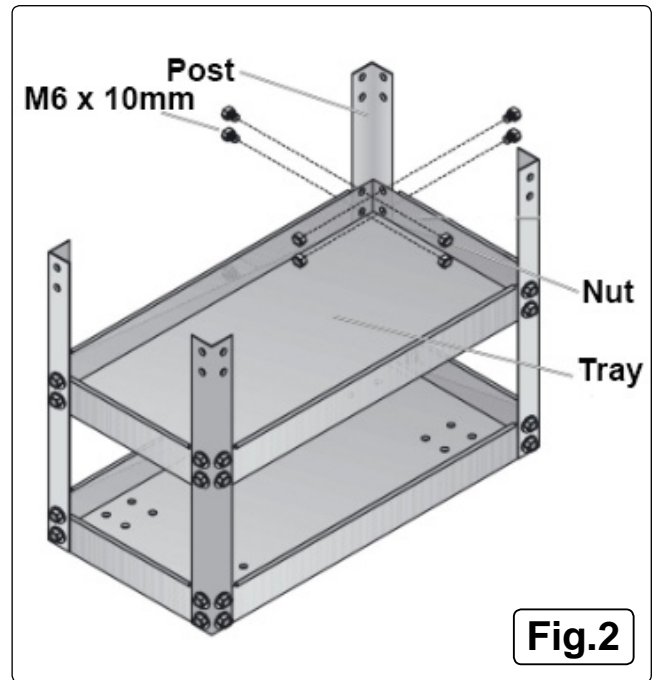
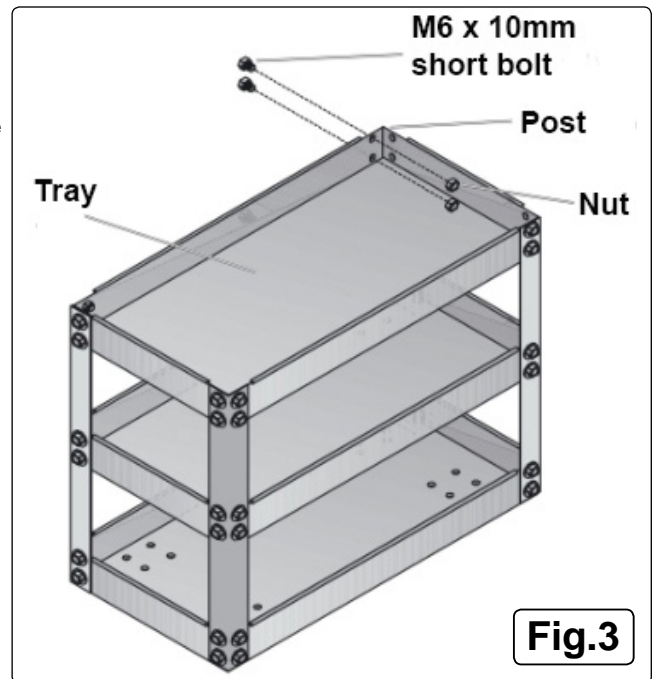

Fig.3

- 4.4. Attach the last tray to the inside top of the posts using 32 x M6 short bolt and nut sets.
- 4.5. The two holes on one end of this top tray are reserved for attaching the tubular steel handle using 2 x M5 long bolt and nuts.
- 4.6. Set the trolley on its side and work on two posts at a time for ease of assembly.
- 4.7. Bolt the castors to the trolley using 16 x M8 x 10mm wheel bolt and nut sets.
- 4.8. The braked castor needs to be at the handle end.
- 4.9. Check all fixings are tight before use.



5. MAINTENANCE

- 5.1. Oil the castors periodically with a light oil. Clean with a damp cloth. **DO NOT** use solvent based cleaners.

Environmental Protection



Recycle unwanted materials instead of disposing of them as waste. All tools, accessories and packaging should be sorted, taken to a recycling centre and disposed of in a manner which is compatible with the environment. When the product becomes completely unserviceable and requires disposal, drain off any fluids (if applicable) into approved containers and dispose of the product and the fluids according to local regulations.

NOTE: It is our policy to continually improve products and as such we reserve the right to alter data, specifications and component parts without prior notice.

IMPORTANT: No liability is accepted for incorrect use of this product.

WARRANTY: Guarantee is 12 months from purchase date, proof of which will be required for any claim.



Sole UK Distributor, Sealey Group.
Kempson Way, Suffolk Business Park,
Bury St. Edmunds, Suffolk.
IP32 7AR



01284 757500



01284 703534



www.sealey.co.uk



sales@sealey.co.uk