



INSTRUCTIONS FOR:  
**HEAVY DUTY MOBILE TOOL & PARTS TROLLEY**  
**2 DRAWERS & LOCKABLE TOP**  
 MODEL NO: **AP760M SERIES**

Thank you for purchasing a Sealey product. Manufactured to a high standard, this product will, if used according to these instructions and maintained properly, give you years of trouble free performance.

**IMPORTANT:** PLEASE READ THESE INSTRUCTIONS CAREFULLY. NOTE THE SAFE OPERATIONAL REQUIREMENTS, WARNINGS & CAUTIONS. USE THE PRODUCT CORRECTLY AND WITH CARE FOR THE PURPOSE FOR WHICH IT IS INTENDED. FAILURE TO DO SO MAY CAUSE DAMAGE AND/OR PERSONAL INJURY AND WILL INVALIDATE THE WARRANTY. KEEP THESE INSTRUCTIONS SAFE FOR FUTURE USE.



Refer to  
 Instruction  
 Manual

### 1. SAFETY

- WARNING!** Ensure Health & Safety, local authority, and general workshop practice regulations are adhered to when using this trolley.
- ✓ Always load evenly with the centre of gravity of the load as near centre of the trolley as possible.
- ✗ **DO NOT** overload the trolley - see section 3.
- ✓ Use the trolley in a suitable work area.
- ✓ Keep the work area clean, uncluttered and ensure there is adequate lighting.
- ✓ Keep the trolley clean and tidy in accordance with good workshop practice.
- ✗ **DO NOT** use the trolley for any purpose other than that for which it is designed.
- ✗ **DO NOT** stand on the trolley, use it as a ladder or allow others to ride on the trolley.
- ✓ Use the wheel locks to prevent the trolley from inadvertently moving.
- ✗ **DO NOT** leave unattended, especially when loaded, unless the wheels are locked, chocked or the trolley otherwise secured.
- ✗ **DO NOT** use trolley on uneven ground and do not run over curbs or steps - use a ramp.
- ✗ **DO NOT** use trolley if any part is significantly damaged, paying particular attention to the wheels.
- ✓ Keep children and unauthorised persons away from the work area.

### 2. INTRODUCTION

Garage or workshop trolley with two shelves and a lockable gas sprung supported lid, which allows for items to be kept safe when not in use. Features two 40kg capacity drawers with ball bearing slides. The unit features an additional screwdriver holder ideal for quick access whilst working. Two lower storage shelves with a 50kg capacity each, can be installed base down or base up to give either tool and component security or unobstructed access. Fitted with four heavy-duty 4" PU castors, two of which are locking.

### 3. SPECIFICATION

<b>Model No:</b> .....	<b>AP760M SERIES</b>
Dimensions (W x D x H):	
Overall Size: .....	925 x 440 x 900mm
Shelf Size (x2): .....	760 x 435 x 60mm
Medium Drawer (x1): .....	560 x 400 x 65mm
Medium Drawer (x1): .....	560 x 400 x 85mm
Upper Tray Size: .....	585 x 435 x 75mm
Total Load Capacity: .....	150kg

### 4. ASSEMBLY

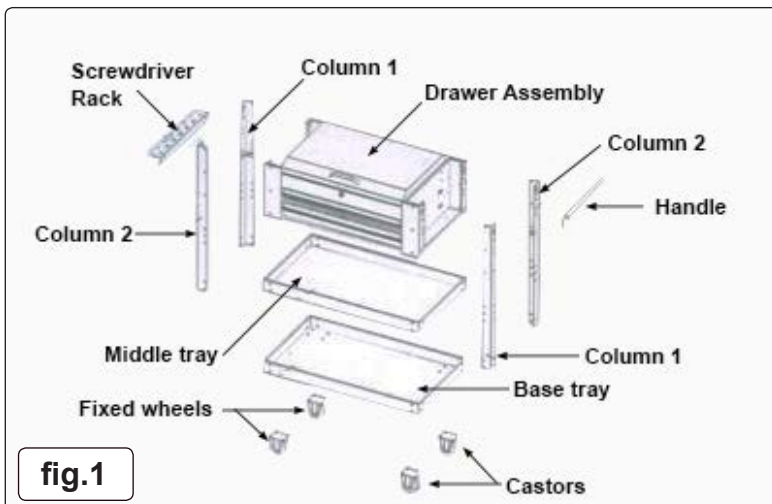

### Refer to fig.1

- 4.1. Lay the base tray, edges upwards, on a flat surface.
- 4.2. Using the nuts and dome-headed screws supplied, attach the columns as shown. The rectangular slots at the top of the columns should face sideways.
- 4.3. Attach the middle tray as shown.
- 4.4. Lower the drawer unit into the columns and attach.
- 4.5. Slide the handle brackets through the rectangular slots and secure from the front (the handle brackets are provided with threaded holes to secure on the inside).
- 4.6. Secure the screwdriver holder to the opposite end of the drawer assembly as in fig.2.
- 4.7. Lay the trolley on its side and fix the castors to the base tray at the same end as the handle. Use four nuts and hex headed screws each.
- 4.8. Fix the two fixed wheels to the opposite end in the same manner.
- 4.9. Check that all fixings are tight.

## 5. MAINTENANCE

- 5.1. Oil the castors periodically with light oil.
- 5.2. Clean with a damp cloth. **DO NOT** use abrasive or solvent cleaners.



fig.2



### ENVIRONMENT PROTECTION

Recycle unwanted materials instead of disposing of them as waste. All tools, accessories and packaging should be sorted, taken to a recycling centre and disposed of in a manner which is compatible with the environment. When the product becomes completely unserviceable and requires disposal, drain any fluids (if applicable) into approved containers and dispose of the product and fluids according to local regulations.

**Note:** It is our policy to continually improve products and as such we reserve the right to alter data, specifications and component parts without prior notice.

**Important:** No Liability is accepted for incorrect use of this product.

**Warranty:** Guarantee is 12 months from purchase date, proof of which is required for any claim.

Sealey Group, Kempson Way, Suffolk Business Park, Bury St Edmunds, Suffolk. IP32 7AR



01284 757500



01284 703534



sales@sealey.co.uk



www.sealey.co.uk