



INSTRUCTIONS FOR UNIVERSAL DOWELLING JIG

MODEL NO: **DJ01**

Thank you for purchasing a Sealey product. Manufactured to a high standard, this product will, if used according to these instructions, and properly maintained, give you years of trouble free performance.

IMPORTANT: PLEASE READ THESE INSTRUCTIONS CAREFULLY. NOTE THE SAFE OPERATIONAL REQUIREMENTS, WARNINGS & CAUTIONS. USE THE PRODUCT CORRECTLY AND WITH CARE FOR THE PURPOSE FOR WHICH IT IS INTENDED. FAILURE TO DO SO MAY CAUSE DAMAGE AND/OR PERSONAL INJURY AND WILL INVALIDATE THE WARRANTY. KEEP THESE INSTRUCTIONS SAFE FOR FUTURE USE.



Refer to instruction manual



Wear protective gloves



Wear eye protection



Wear face mask



Wear protective clothing

1. SAFETY

- ✓ Wear appropriate Personal Protective Equipment. A full range of Personal Protective Equipment is available from your Sealey stockist.
- ✓ Use the tool in a suitable work area. Keep area clean and tidy and free from unrelated materials and ensure that there is adequate lighting.
- ✓ Secure any unstable workpieces with a clamp, vice or other adequate holding device.
- ✗ **DO NOT** over-reach. Ensure the floor is not slippery and wear non-slip shoes.
- ✗ **DO NOT** use the tool for a task it is not designed to perform.
- ✗ **DO NOT** get the tool wet or use in damp or wet locations.
- ✗ **DO NOT** hold unsecured work in your hand.
- ✗ **DO NOT** operate the tool if any parts are missing or damaged as this may cause failure and/or personal injury.
- ✗ **DO NOT** operate the tool when you are tired or under the influence of alcohol, drugs or intoxicating medication.

2. INTRODUCTION

Jig and clamp dowelling set ideal for making accurate 6, 8 and 10mm dowel holes/joints in MDF and wood. Suitable for a number of different styles of dowel joint including edge-to-edge, edge-to-corner and edge-to-surface. Set includes aluminium dowelling jig, alignment clamps, 60 dowel pins and three drill bit depth stops.

3. SPECIFICATION

Model No:DJ01
Dowel Sizes 6mm, 8mm, 10mm
Suitable Thickness MDF/Wood 12mm to 36mm

4. CONTENTS

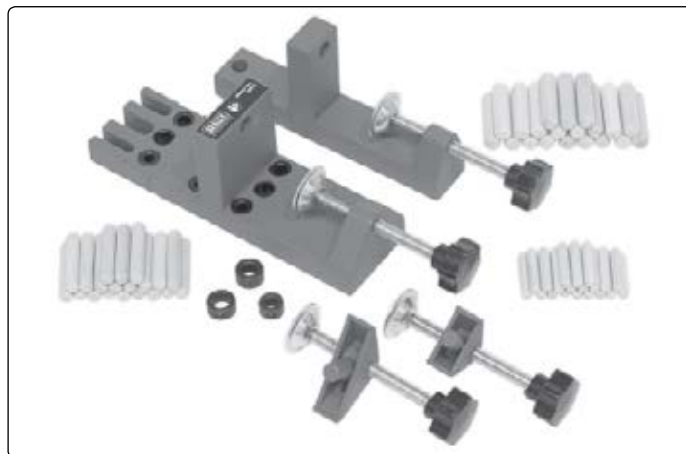

5. OPERATION

NOTE: These instructions are guidelines only and cannot cover all aspects of creating perfect joints. It is suggested that the use of a set square, spirit level and additional clamping will enhance the final product. All cuts on the materials to be dowelled together must be square and true or errors will compound and affect the quality of the joint. If materials to be joined are not uniform and consistent in thickness, errors may occur in the alignment of jointed surfaces

NOTE: There are three different common forms of dowelled joint: 'Edge to Edge', 'Edge to Corner' and 'Edge to Surface'.

5.1. EDGE TO EDGE JOINTING (fig.1)

- 5.1.1. Clamp the first board in position on the work bench using drill jig (fig.1.A) and clamp block (fig.1.B) thus setting the location for the first dowel hole.
- 5.1.2. Rest second board onto drill jig and clamp block platforms and secure with upper clamps (fig.1.C). **TIP:** Support the upper board securely so that the boards lie parallel to each other and ensure that edges are in line.

- 5.1.3. Select dowel size and relevant drill bit. Set the depth gauge on the drill bit to ensure sufficient hole depth to prevent the dowel from bottoming out when jointing thus preventing the boards from fully meeting. Drill both upper and lower holes at this position.
TIP: To prevent build up of swarf, withdraw the drill bit from the work frequently.
- 5.1.4. To continue drilling further holes, loosen the drill jig clamps and carefully slide the drill jig to it's new position. **TIP:** Spacing can be achieved by placing a dowel into an existing hole and using a spacer-block between this and the drill-jig to set the new location.
IMPORTANT: When moving the drill jig location at least one set of clamps must be holding the boards in position to prevent movement and misalignment of the dowels.

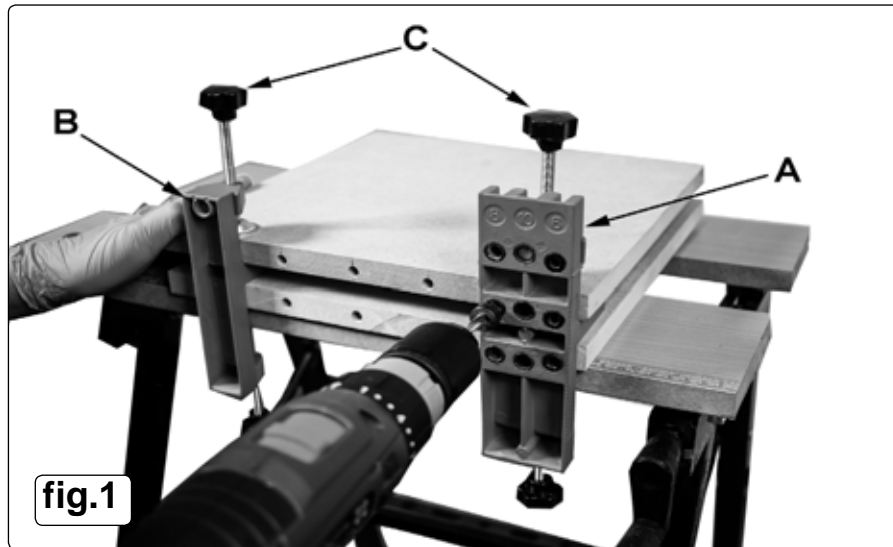

fig.1

5.2. EDGE TO CORNER JOINTING (fig.2)

- 5.2.1. Clamp the first board in position on the work bench using drill jig (fig.2.A) and clamp block (fig.2.B) thus setting the location for the first dowel hole.
- 5.2.2. Stand the second board on edge onto the drill jig and secure with upper clamps. **TIP:** Support the vertical board securely so that the boards lie at right angles to each other and ensure that edges are in line. Additional clamping maybe required to securely and firmly support the vertical board.
- 5.2.3. Select dowel size and relevant drill bit. Set the depth gauge on the drill bit to ensure sufficient hole depth to prevent the dowel from bottoming out on jointing thus preventing the boards from fully meeting. Drill all holes in the horizontal board. **TIP:** Spacing can be achieved by placing a dowel into an existing hole and using spacer-block between this and the drill-jig to set the new location.
- 5.2.4. Re-adjust drill depth gauge to suit hole depth required in vertical board. To continue drilling further holes, loosen the drill jig clamps and carefully slide the drill jig to it's new position. **TIP:** Alignment of upper and lower holes can be achieved by using a dowel placed in matching horizontal hole (fig.2C) **TIP:** To prevent build up of swarf, withdraw the drill bit from the work frequently.
IMPORTANT: When moving the jig location at least one set of clamps must be holding the boards in position to prevent movement and misalignment of the dowels.

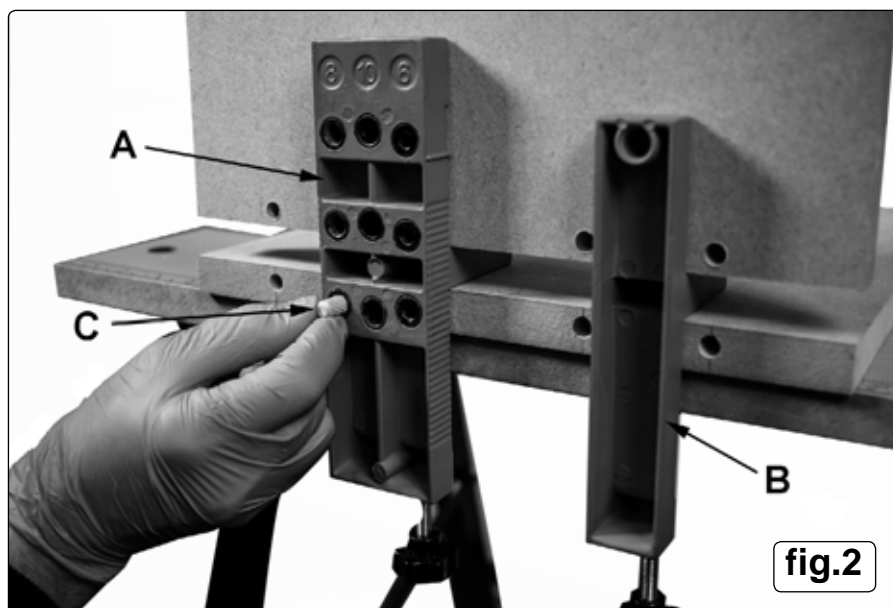
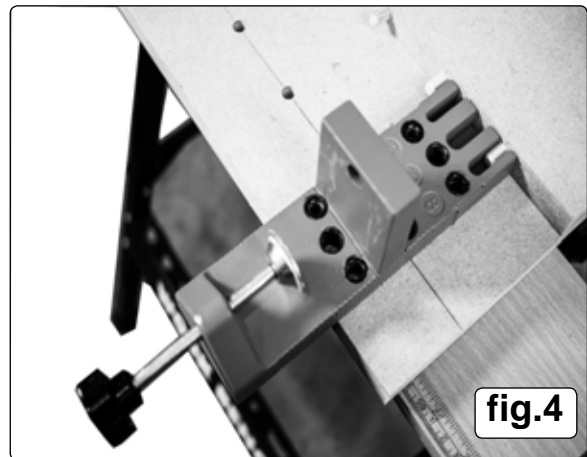
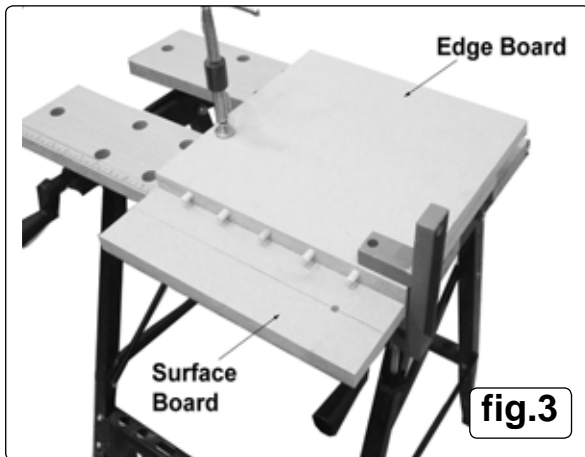

fig.2

5.3. EDGE TO SURFACE JOINTING (fig.3, fig.4)

- 5.3.1. Mark centre line of dowel fixings in surface board and place in position on the work bench (fig.3).
- 5.3.2. Lay pre-drilled edge board in position on top of surface board (fig.3) ensuring alignment of edges. Place edge board by adjusting its position such that the centre line of the dowel holes is dead centre to the relevant guide bush (fig.4) Clamp in place using clamp block.
NOTE: Use additional clamping if required.
- 5.3.3. Locate the jig on the protruding dowels (fig.4) using the relevant slot for the guide bush being used.
- 5.3.4. Select dowel size and relevant drill bit. Set the depth gauge on the drill bit to ensure sufficient hole depth to prevent the dowel from bottoming out on jointing thus preventing the boards from fully meeting.
- 5.3.5. To continue drilling further holes, loosen the drill jig clamps and carefully slide the drill jig to it's new position. **TIP:** Spacing can be achieved by placing a dowel into an existing hole and using a spacer-block between this and the drill jig to set the new location.
IMPORTANT: When moving the drill jig location at least one set of clamps must be holding the board in position to prevent movement and misalignment of the dowels.



ENVIRONMENT PROTECTION

Recycle unwanted materials instead of disposing of them as waste. All tools, accessories and packaging should be sorted, taken to a recycling centre and disposed of in a manner which is compatible with the environment. When the product becomes completely unserviceable and requires disposal, drain any fluids (if applicable) into approved containers and dispose of the product and fluids according to local regulations.

Note: It is our policy to continually improve products and as such we reserve the right to alter data, specifications and component parts without prior notice.

Important: No Liability is accepted for incorrect use of this product.

Warranty: Guarantee is 12 months from purchase date, proof of which is required for any claim.

Sealey Group, Kempson Way, Suffolk Business Park, Bury St Edmunds, Suffolk. IP32 7AR



01284 757500



01284 703534



sales@sealey.co.uk



www.sealey.co.uk