



Ø230MM ANGLE GRINDER 2000W

MODEL NO.: **SAG230**

Thank you for purchasing a Sealey product. Manufactured to a high standard, this product will, if used according to these instructions, and properly maintained, give you years of trouble free performance.

IMPORTANT: PLEASE READ THESE INSTRUCTIONS CAREFULLY. NOTE THE SAFE OPERATIONAL REQUIREMENTS, WARNINGS & CAUTIONS. USE THE PRODUCT CORRECTLY AND WITH CARE FOR THE PURPOSE FOR WHICH IT IS INTENDED. FAILURE TO DO SO MAY CAUSE DAMAGE AND/OR PERSONAL INJURY AND WILL INVALIDATE THE WARRANTY. KEEP THESE INSTRUCTIONS SAFE FOR FUTURE USE.



Refer to instructions



Wear eye protection



Wear protective gloves



Wear safety footwear



Wear protective clothing



Wear ear protection



Wear a mask



Wear respiratory mask (fumes)

1. INTRODUCTION

1.1. ELECTRICAL SAFETY

- ❑ **WARNING!** It is the user's responsibility to check the following:
 - Check all electrical equipment and appliances to ensure that they are safe before using. Inspect power supply leads, plugs and all electrical connections for wear and damage. Sealey recommend that an RCD (Residual Current Device) is used with all electrical products. You may obtain an RCD by contacting your local Sealey stockist.
 - If the product is used in the course of business duties, it must be maintained in a safe condition and routinely PAT (Portable Appliance Test) tested.
 - Electrical safety information, it is important that the following information is read and understood.
- 1.1.1. Ensure that the insulation on all cables and on the appliance is safe before connecting it to the power supply.
- 1.1.2. Regularly inspect power supply cables and plugs for wear or damage and check all connections to ensure that they are secure.
- 1.1.3. **IMPORTANT:** Ensure that the voltage rating on the appliance suits the power supply to be used and that the plug is fitted with the correct fuse - see fuse rating in these instructions.
 - * **DO NOT** pull or carry the appliance by the power cable.
 - * **DO NOT** pull the plug from the socket by the cable. Remove the plug from the socket by maintaining a firm grip on the plug.
 - * **DO NOT** use worn or damaged cables, plugs or connectors. Ensure that any faulty item is repaired or replaced immediately by a qualified electrician.
- 1.1.4. This product is fitted with a BS1363/A 13 Amp 3 pin plug.
 - If the cable or plug is damaged during use, switch the electricity supply and remove from use.
 - Replace a damaged plug with a BS1363/A 13 Amp 3 pin plug. If in doubt contact a qualified electrician.
 - Class II products are wired with live (brown) and neutral (blue) only are marked with Class II symbol.
 - A) Connect the BROWN live wire to the live terminal 'L'.
 - B) Connect the BLUE neutral wire to the neutral terminal 'N'.
 - C) After wiring, check that there are no bare wires and ensure that all wires have been correctly connected.
 - Ensure that the cable outer sheath extends inside the cable restraint and that the restraint is tight.
 - * **DO NOT** connect either wire to the earth terminal.

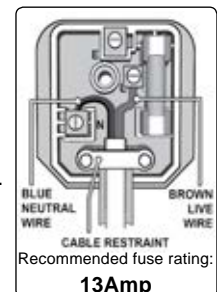

1.2. GENERAL SAFETY

- ✓ Disconnect the grinder from the mains power before changing accessories, servicing or performing any maintenance.
- ✓ Maintain grinder and discs in good condition. Check moving parts and alignment. If necessary use an authorised service agent.
- ✓ Replace or repair damaged parts. *Use recommended parts only. Unauthorised parts may be dangerous and will invalidate the warranty.*
- ❑ **WARNING!** Always work with the grinder's safety guard in place.
- ✓ Wear approved safety goggles, ear defenders, gloves and, if grinder generates dust, a dust mask.
- ✓ Position the power cable clear of the grinding wheel to avoid cutting or snagging it. Hold grinder only by insulated gripping surfaces.
- ✓ Remove ill fitting clothing. Remove ties, watches, rings and other loose jewellery and contain long hair.
- ✓ Use grinder in a suitable work area. Keep area clean, tidy and free from unrelated materials and ensure adequate lighting.
- ✓ Maintain correct balance and footing, **DO NOT** over-reach. Ensure the floor is not slippery and wear non-slip shoes.
- ✓ Use only approved grinding discs and only use the normal grinding surface.
- ✓ Check grinding disc to ensure there are no splits, cracks or other damage (see Section 6). If in doubt **DO NOT** use the disc.
- ✓ Grinding discs must be securely attached before use, but not over-tightened.
- ✓ Secure unstable workpiece with a clamp, vice or other adequate holding device and ensure the grinder is gripped with both hands.
- ✓ Keep non-essential persons away from the working area, use screens if necessary.
- * **DO NOT** operate the grinder if any parts are missing or the grinder is damaged.
- * **DO NOT** use the grinder for a task it is not designed to perform.
- * **DO NOT** operate the grinder where there are flammable solids, liquids or gasses.
- ❑ **WARNING! DO NOT** grind any materials containing asbestos.
- * **DO NOT** get the grinder wet or use in damp or wet locations.
- * **DO NOT** switch the grinder on whilst the disc is in contact with the workpiece.
- * **DO NOT** cover the grinder air vents. To do so will overheat the machine.
- * **DO NOT** touch the workpiece immediately after grinding, it will be very hot.
- * **DO NOT** use the grinder as a fixed tool and **DO NOT** try to cool the grinding disc with water or other lubricants.

- ✗ **DO NOT** touch the grinding disc whilst operating, or whilst plugged into the mains power.
- ✗ **DO NOT** leave the grinder running unattended, and **DO NOT** lay the grinder down whilst it is running.
- ✗ **DO NOT** operate the grinder when you are tired or under the influence of alcohol, drugs or intoxicating medication.
- ✓ When not in use switch off grinder, remove plug from power supply and store in safe, dry, childproof area.
- ✓ Use only approved grinding discs and only use the normal grinding surface. Never use the side or upper surface of disc for cutting.
- ✓ The grinding disc may only be changed by a person holding a grinding wheel certificate.
- ✓ Grinding discs must be securely attached before use, but not overtightened.

DANGER OF FIRE/EXPLOSION HAZARD

- ❑ **WARNING! The grinding process can produce streams of sparks which are a potential source of ignition, especially when grinding metal.**
- ✗ **DO NOT use the grinder where there are flammable liquids, solids or gases.**
- ✗ **DO NOT allow grinder sparks to make contact with the operator's clothing or any other fabric such as cleaning rags. Fabrics contaminated with flammable materials such as petrol, oil, grease, paint and solvents are a particular fire hazard.**
- ✓ **To reduce the risk of clothing catching fire the operator should wear wool or cotton outer garments treated with a fire retardant in preference to man-made fibres.**

2. INTRODUCTION

Heavy-duty alloy bevel gear head with composite body housing a powerful 2000W motor. Vibration reducing double injection composite body with rubber coating for added comfort. Powerful 2000W heavy-duty motor produces 6500rpm (no load speed). Tool-less wheel guard for quick and easy adjustment. Built-in LED power indicator. Two stage trigger for added safety. Fitted with soft start to reduce mains draw when switched on. Spindle lock device for fast loading/unloading of discs. Supplied with side handle, guard and spanner. Fitted with over 2m of power cable and 3-pin plug. Grinding disc not included, order Model No. PTC/230G.

3. SPECIFICATION

Model.....	SAG230
Motor Power	2000W
Free speed.....	6500rpm
Spindle size.....	M14 x 2mm
Disc size.....	Ø230mm
Noise power	103dB(A)
Noise pressure	92dB(A)
Vibration/Uncertainty	5.175m/s ² K=1.5m/s ²

4. ASSEMBLY

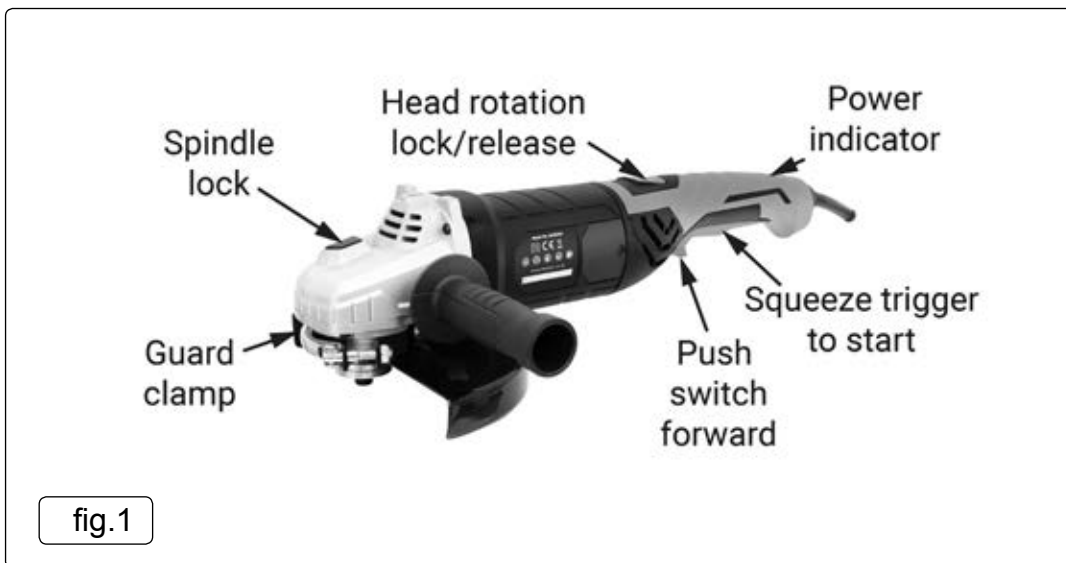

fig.1

- ❑ **WARNING!** Ensure that the grinder is unplugged from the power supply before assembly/adjustments/maintenance.
- 4.1. FITTING THE GUARD ASSEMBLY**
- ❑ **WARNING!** Always work with the grinder's safety guard in place.
- 4.1.1. The guard may be orientated at any angle to suit the grinding task required and should be positioned to allow maximum working performance whilst providing maximum personal protection for the operator.
- 4.1.2. Loosen guard locking device and turn the guard to the required position. Lock the guard in place by re-tightening the locking device.
- 4.2. ATTACHING A GRINDING/CUTTING DISC**
- NOTE:** Discs should only be fitted by a person holding a grinding wheel certificate.
- 4.2.1. Lay the grinder on it's back and place the clamping flange onto the centre spindle with the raised ring facing upwards (see fig.2).
- 4.2.2. Rotate the clamping flange on the spindle until the flats on its back face drop into alignment with the flats on the spindle. When the clamping flange is in the correct position it can no longer be rotated on the spindle.
- 4.2.3. Place the grinding (or cutting) disc over the spindle and onto the clamping flange. Figures 2, 3, and 4 show the correct orientation of the retaining flange nut for the different types of disc.
- 4.2.4. When using a grinding disc with a depressed centre portion as in fig.4, screw the disc retaining flange nut onto the spindle with the raised ring facing downwards.
- 4.2.5. When using flat cutting discs as in fig.2 and cutting discs with a depressed centre portion as in fig.3, screw the disc retaining flange nut onto the spindle with the raised ring facing upwards.
- 4.2.6. Stop the spindle from turning by pushing in and holding down the spindle lock button (fig.1).

- 4.2.7. Lock the grinding/cutting disc into place by tightening the disc retaining flange nut with the supplied pin wrench.
 4.2.8. When complete, release the locking button and check that it has sprung back to its initial position.

4.3. FITTING THE HANDLE

Always use the handle for better control and improved safety. Fit the handle by screwing it into the appropriate left, right or top position on the grinder head.

5. OPERATION

- **WARNING!** Ensure grinder is unplugged from the mains power supply before changing accessories.

5.1. PREPARATION

- 5.1.1. Attach grinding/cutting disc according to section 4.2 and figures 2, 3 and 4. Position the handle conveniently for the task.
 5.1.2. Ensure the disc safety guard is correctly positioned and securely fitted.
 5.1.3. Plug grinder into the mains power supply.

- **WARNING!** When the grinder first starts it will kick to the right. You must ensure, therefore, that the tool is securely gripped in both hands. Especially important is the position you choose for the side handle in order to maintain stability.

- **WARNING!** Before use, ensure that you are wearing approved safety goggles, ear defenders, appropriate dust mask if dust will be generated and safety gloves, and that all other safety instructions in Section 1 are followed carefully.

5.2. ON/OFF CONTROL (fig.1)

- 5.2.1. The ON/OFF switch is designed to avoid accidental starting.
 5.2.2. Once plugged into the power supply start the grinder by pushing the switch (fig.1) forward and simultaneously squeezing the trigger.
 5.2.3. To stop the machine release the trigger.
 5.2.4. If the power to the grinder is cut whilst in use release the trigger and unplug the grinder. **DO NOT** reconnect the grinder until you are sure that the power has been restored.

5.3. GRINDING HEAD ALIGNMENT

- 5.3.1. To rotate the grinding head to any orthogonal position (0°, 90°, 180°, 270°) depress the locking switch (fig.1) and twist the head to the required position. Ensure it is fully engaged in place before turning the power on.

5.4. GRINDING

- 5.4.1. The key to effective operating is controlling the pressure and surface contact between the disc and the work piece.

- **WARNING! DO NOT** switch the grinder on whilst the disc is in contact with the work piece. Bring the rotating disc to the work piece.

- 5.4.2. Allow the disc to reach full speed before starting to grind.
 5.4.3. Grind flat surfaces at an angle of between 10° to 20° to the work piece. Too great an angle will cause a concentration of pressure in one small area resulting in gouging or burning of the surface.
 5.4.4. When grinding is complete allow the work piece to cool. **DO NOT** touch the hot surface.
 5.4.5. Unplug the grinder from the mains power supply, clean and store in a safe, dry, childproof area.

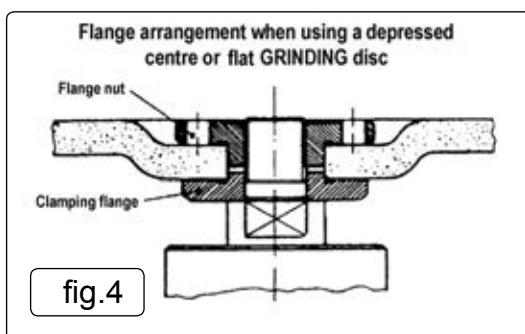
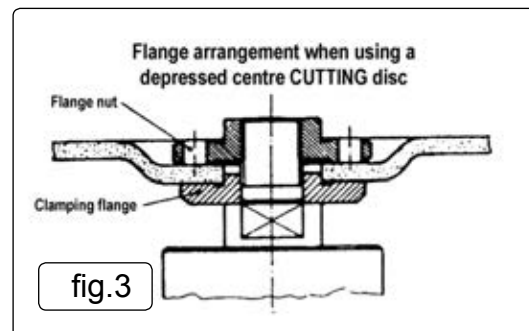
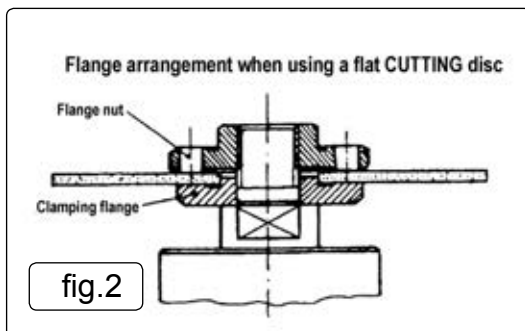

6. GRINDING DISCS

- **WARNING! DO NOT USE DISCS THAT ARE DAMAGED, OR SUSPECTED TO BE DAMAGED.**

- 6.1. Before using a grinding/cutting disc ensure that there are no fissures or cracks. Once mounted on the grinder, test the disc before use by facing the grinder in a safe direction (point away from yourself, others and vulnerable items) and run for a short time.

- ▲ **DANGER!** Use of damaged discs is dangerous and may cause personal injury.

- 6.2. Grinding and cutting discs used in association with this machine shall be of an adequate speed rating and be suitable for the job in hand. Only persons holding a grinding wheel certificate are authorised to change grinding discs. Ensure that the speed rating on the disc is equal to, or higher than, that of the grinder.

7. MAINTENANCE

- ☐ **WARNING:** Always disconnect the power supply before carrying out any inspection, maintenance or cleaning.

7.1. GENERAL INSPECTION

- 7.1.1. Regularly check that all the fixing screws are tight.
- 7.1.2. Repairs should be carried out by an authorised service centre.

7.2. CLEANING

- ☐ **WARNING:** Always wear protective equipment including eye protection and gloves when cleaning this tool.

- 7.2.1. Keep your tool clean at all times. Dirt and dust will cause internal parts to wear quickly, and shorten the device's service life.
- 7.2.2. Clean the body of your machine with a soft brush, or dry cloth.
- 7.2.3. Never use caustic agents to clean plastic parts. If dry cleaning is not sufficient, a mild detergent on a damp cloth is recommended.
- 7.2.4. Water must never come into contact with the tool. Ensure the tool is thoroughly dry before using it.
- 7.2.5. If available, use clean, dry, compressed air to blow through the ventilation holes (where applicable).

7.3. STORAGE

- 7.3.1. Store this tool carefully in a secure, dry place out of the reach of children.

WARNING! – Risk of Hand Arm Vibration Injury.

This tool may cause Hand Arm Vibration Syndrome if its use is not managed adequately.

This tool is subject to the vibration testing section of the Machinery Directive 2006/42/EC.

This tool is to be operated in accordance with these instructions.

Measured vibration emission value (a): 5.175 m/s²

Uncertainty value (k): 1.5 m/s²

Please note that the application of the tool to a sole specialist task may produce a different average vibration emission. We recommend that a specific evaluation of the vibration emission is conducted prior to commencing with a specialist task.

A health and safety assessment by the user (or employer) will need to be carried out to determine the suitable duration of use for each tool.

NB: Stated Vibration Emission values are type-test values and are intended to be typical.

Whilst in use, the actual value will vary considerably from and depend on many factors.

Such factors include; the operator, the task and the inserted tool or consumable.

NB: ensure that the length of leader hoses is sufficient to allow unrestricted use, as this also helps to reduce vibration.

The state of maintenance of the tool itself is also an important factor, a poorly maintained tool will also increase the risk of Hand Arm Vibration Syndrome.

Health surveillance.

We recommend a program of health surveillance to detect early symptoms of vibration injury so that management procedures can be modified accordingly.

Personal protective equipment.

We are not aware of any personal protective equipment (PPE) that provides protection against vibration injury that may result from the uncontrolled use of this tool. We recommend a sufficient supply of clothing (including gloves) to enable the operator to remain warm and dry and maintain good blood circulation in fingers etc. Please note that the most effective protection is prevention, please refer to the Correct Use and Maintenance section in these instructions. Guidance relating to the management of hand arm vibration can be found on the HSC website www.hse.gov.uk - Hand-Arm Vibration at Work.

Parts support is available for this product. Please email sales@sealey.co.uk or telephone 01284 757500



WEEE REGULATIONS

Dispose of this product at the end of its working life in compliance with the EU Directive on Waste Electrical and Electronic Equipment (WEEE). When the product is no longer required, it must be disposed of in an environmentally protective way. Contact your local solid waste authority for recycling information.



ENVIRONMENT PROTECTION

Recycle unwanted materials instead of disposing of them as waste. All tools, accessories and packaging should be sorted, taken to a recycling centre and disposed of in a manner which is compatible with the environment. When the product becomes completely unserviceable and requires disposal, drain any fluids (if applicable) into approved containers and dispose of the product and fluids according to local regulations.

Note: It is our policy to continually improve products and as such we reserve the right to alter data, specifications and component parts without prior notice.

Important: No Liability is accepted for incorrect use of this product.

Warranty: Guarantee is 12 months from purchase date, proof of which is required for any claim.

Sealey Group, Kempson Way, Suffolk Business Park, Bury St Edmunds, Suffolk. IP32 7AR



01284 757500



01284 703534



sales@sealey.co.uk



www.sealey.co.uk