



20V CIRCULAR SAW Ø150MM - BODY ONLY

MODEL NO: **CP20VCS**

Thank you for purchasing a Sealey product. Manufactured to a high standard, this product will, if used according to these instructions, and properly maintained, give you years of trouble free performance.

IMPORTANT: PLEASE READ THESE INSTRUCTIONS CAREFULLY. NOTE THE SAFE OPERATIONAL REQUIREMENTS, WARNINGS & CAUTIONS. USE THE PRODUCT CORRECTLY AND WITH CARE FOR THE PURPOSE FOR WHICH IT IS INTENDED. FAILURE TO DO SO MAY CAUSE DAMAGE AND/OR PERSONAL INJURY AND WILL INVALIDATE THE WARRANTY. KEEP THESE INSTRUCTIONS SAFE FOR FUTURE USE.



Refer to instructions



Wear eye protection



Wear protective gloves



Wear safety footwear



Wear protective clothing



Wear ear protection



Warning!
Laser beam



Wear dust mask

1. SAFETY

1.1. GENERAL SAFETY

- WARNING!** Ensure that Health & Safety, local authority and general workshop practice regulations are adhered to when using this equipment.
- WARNING! DO NOT** aim the laser beams at your or another person's or animal's eye and beware of reflections from mirrors or other shiny surfaces.
- ✓ Remove the battery from the saw before changing blades, servicing or performing any maintenance.
- ✓ Maintain the saw in good condition. Check moving parts alignment on a regular basis.
- ✓ Replace or repair damaged parts. Use an authorised service agent and use recommended parts only. Unauthorised parts may be dangerous and will invalidate the warranty.
- ✓ Keep the saw clean and the blade sharp for best and safest performance.
- ✓ Wear approved safety eye protection (standard spectacles are not adequate) and dust mask.
- ✓ Maintain correct balance and footing. Ensure the floor is not slippery and wear non-slip shoes.
- ✓ Keep children and unauthorised persons away from the working area.
- ✓ Remove ill fitting clothing. Remove ties, watches, rings and other loose jewellery and contain long hair.
- ✓ Use in a suitable work area. Keep area clean, tidy and free from unrelated materials. Ensure there is adequate lighting.
- ✓ Ensure locking hex. key is removed from the blade clamp flange before starting saw.
- ✓ Evaluate your work area before using the saw e.g. partitions may conceal electric cables or water piping.
- ✓ Secure non-stable workpiece with a clamp, vice or other adequate holding device.
- ✓ Avoid unintentional starting.
- ✓ Before making a cut ensure that all accessories and adjustment fixings are fully tightened.
- ✓ Only use saw blades that are specifically designed for use with this machine.
- ✓ Always use the side fence supplied or a securely fixed straight edge guide when doing a rip cut (along the length of the grain).
- ✓ When not in use store in a safe, dry, childproof area .
- * **DO NOT** use the saw where there are flammable liquids, solids or gases such as paint solvents, etc.
- * **DO NOT** allow children to operate the saw.
- * **DO NOT** operate the saw if any parts are missing as this may cause failure and/or personal injury.
- * **DO NOT** leave the saw operating unattended.
- * **DO NOT** carry the saw with your finger on the power switch.
- * **DO NOT** use the saw for a task it is not designed to perform.
- * **DO NOT** use a blade which is damaged, cracked, distorted or has missing teeth.
- * **DO NOT** tamper with, or remove, blade guard.
- * **DO NOT** operate the saw when you are tired, under the influence of alcohol, drugs or intoxicating medication.
- * **DO NOT** get the saw wet or use in damp or wet locations.
- * **DO NOT** hold unsecured workpiece in your hand whilst cutting.
- * **DO NOT** force the saw to cut but allow it to operate at its normal working speed.
- * **DO NOT** use the saw with any other manufacturers' accessories.
- * **DO NOT** reach under the workpiece whilst the blade is cutting. Keep hands away from the cutting area and do not attempt to remove cut material whilst the blade is still turning.
- * **DO NOT** wedge the blade guard open.
- * **DO NOT** fit or use a saw blade that is intended to cut metal. Always ensure that the saw is fitted with the correct wood cutting blade.
- * **DO NOT** substitute an abrasive wheel for the saw blade.
- * **DO NOT** allow the blade to come into contact with nails or other steel fixings used in old timber or existing timber structures. Inspect the workpiece before commencing cutting and remove any potential hazards.
- * **DO NOT** attempt to stop the saw by pressing on the side of the blade.
- * **DO NOT** start the saw with the blade in contact with the workpiece. Allow the blade to run up to speed before proceeding to cut.

1.2. LASER SAFETY

- WARNING! DO NOT** look or stare into the laser beam as permanent eye damage could result.
The CP20VCS utilises a Class II laser that emits low levels of visible radiation (i.e. wavelengths between 400 and 700 nanometres) which are safe for the skin but not inherently safe for the eyes. The Class II emission limit is set at the maximum level for which eye protection is normally afforded by natural aversion responses to bright light.

Accidental eye exposure is therefore normally safe, although the natural aversion response can be overridden by deliberately staring into the beam, and can also be influenced by the use of alcohol or drugs.

- ✓ Be aware that reflections of the laser beam from mirrors or other shiny surfaces can be as hazardous as direct eye exposure.

2. INTRODUCTION

Powerful, lightweight cordless circular saw suitable for cutting wood, board and soft metals. Durable composite housing with soft grip for added comfort. Tool-free adjustment of cutting angle, depth and width. Built-in laser guide for accurate cutting. Supplied with Ø150mm saw blade. Two stage operation switch for added safety. Requires Model No's CP20VBP, CP20VBP2 or CP20VBP4 20V Battery and Model No. CP20VMC Mains Charger.

3. SPECIFICATION

Model no.: **CP20VCS**

Battery (not included):20V 2Ah - 3 Ah - 4 Ah Li-ion Battery

No load blade speed: 4200 rpm

Blade diameter: Ø150 mm

Disc bore size: Ø10 mm

Cutting depth - 90°: 48 mm

Cutting depth - 45°: 33 mm

Acoustic pressure: 79 dB(A)

Acoustic power: 90 dB(A)

Consumables:

2 Ah Battery - CP20VBP2

3 Ah Battery - CP20VBP

4 Ah Battery - CP20VBP4

Replacement parts

Mains charger - CP20VMC

Saw blade - CP20VCS-03



4. OPERATION

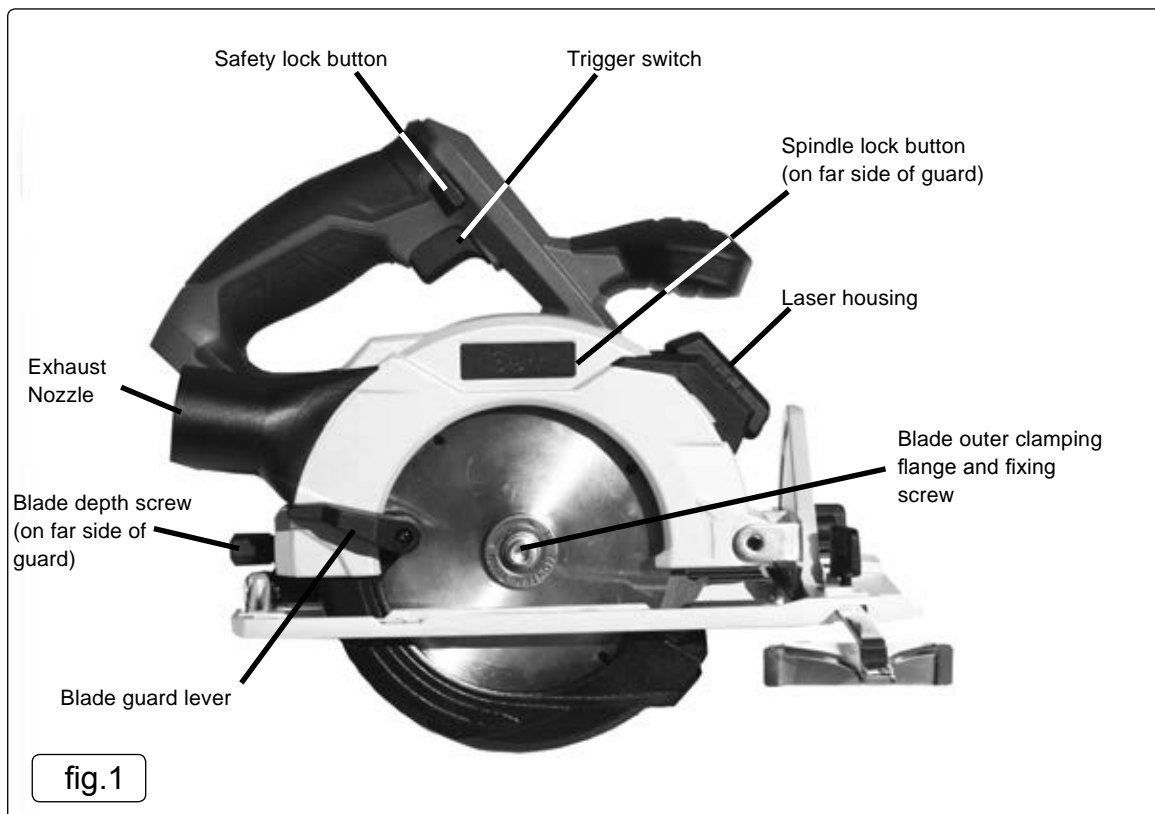

- WARNING!** Remove battery before replacing blades or carrying out any adjustment or maintenance.
- 4.1. **SAFETY LOCK-OFF FEATURE (fig.1)**
The saw is fitted with a safety lock-off button to help prevent accidental saw startups. To operate the saw, press the safety lock-off button (in either direction) while pressing the trigger switch.
- 4.2. **REMOVING AND REFITTING THE SAW BLADE (fig.1)**
 - WARNING!** Always use blades of correct size and shape of arbour hole.
 - WARNING!** Never use damaged or incorrect blade clamping washers or bolt. The blade washers and bolt were specifically designed for your saw, for optimum performance and safety of operation.
 - WARNING!** Always use blades with the correct size and shape (diamond versus round) of arbour holes. Blades that do not match the the mounting hardware of the saw will run eccentrically, causing loss of control.
- 4.2.1. Fully depress the spindle lock button (fig.1) and use the supplied hex key to undo the socket head cap screw holding the outer flange (fig.1) in situ. Remove the screw and outer flange.
- 4.2.2. Pull the blade guard back using the lever (fig.1) and carefully lift the blade off the spindle and withdraw it out from the housing.

- 4.2.3. Slide the new blade into position ensuring the correct rotational alignment.
- 4.2.4. Replace outer flange and socket head cap screw. Apply spindle lock and fully tighten the screw to ensure firm location of the blade.
- 4.3. PREPARATION**
- 4.3.1. Check the guard for proper closing before each use. **DO NOT** operate the saw if the guard does not move freely and close instantly. Never clamp or tie the guard into the open position. If the saw is accidentally dropped the guard may be bent. Raise the guard using the blade guard lever (fig.1) and make sure it moves freely and does not touch the blade or any other part, in all angles and depths of cut.
- 4.3.2. Check the operation of the guard spring. If the guard and spring are not operating properly, they must be serviced before use. The guard may operate sluggishly due to damaged parts, gummy deposits, or a build up of debris.
- 4.3.3. The guard may be retracted manually only for special cuts such as “plunge cuts” and “compound cuts”. Raise the guard using the lever (fig.1) and as soon as the blade enters the material the guard must be released. For all other sawing the guard should operate automatically.
- **WARNING!** If the unit is accidentally knocked or dropped check that the blade guard still operates easily and smoothly. If the blade guard is damaged stop using the saw until the guard is repaired or replaced.
- 4.4. ADJUSTMENTS**
- 4.4.1. **To adjust the parallel guide (fig.2)** loosen clamp screw (fig.2) and slide the guide to the required distance. When in position re-tighten the clamp screw. **NOTE:** The slide is stamped at 5 mm intervals.
- 4.4.2. **To set the bevel angle** loosen the bevel clamp screw (fig.2) and tilt the saw to the required angle as indicated by the marking stamped on the angle gauge (fig.2). When in position re-tighten the clamp screw.
- 4.4.3. **To adjust the cutting depth** loosen the depth screw (fig.3) and rotate the unit until the blade is at the required depth as indicated by the marking stamped on the depth gauge (fig.3). When the correct depth has been set re-tighten the clamp screw.
- 4.4.4. **To enable vacuum extraction** (vacuum and fittings not supplied) connect the extrication unit to the nozzle (fig.1).
- 4.5. SAWING**
- 4.5.1. Never hold the piece being cut in your hands or across your leg. Secure the workpiece to a stable platform. It is important to support the work properly to to minimize body exposure, blade binding or loss of control.
- 4.5.2. Check that the saw is correctly set up and that all handles and screws are tightened before starting the saw and that the guard operates correctly.
- 4.5.3. Adjust the cutting depth to the thickness of the workpiece. Less than a full tooth of the blade teeth should be visible below the workpiece.
- ▲ **DANGER** Keep hands away from the cutting area and the blade. Keep your second hand on the auxiliary handle or motor housing. If both hands are holding the saw they cannot be cut by the blade.
- × **DO NOT** reach underneath the workpiece as the guard cannot protect you from below the workpiece.
- 4.5.4. Hold the tool by the insulated gripping surfaces only when performing a cutting operation where the cutting tool may contact hidden wiring or it's own cord. Contact with a “live” wire will also mkae exposed metal parts of the power tool “Live” and could give the operator an electric shock.
- 4.5.5. Place the front of the soleplate on the workpiece and position the motor side of the saw over the larger section of the item that is not be sawn off.
- 4.5.6. For vertical cuts follow the 0° mark at the front of the soleplate (fig.4). For bevelling follow the 45° mark at the front of the soleplate (fig.4).
- 4.5.7. Press the safety lock-off button (fig.1) and the trigger to start the saw.
- × **DO NOT** engage the blade to the workpiece until it is up to speed.
- 4.5.8. The laser (fig.1) comes on when the motor starts. The laser beam will shine in front of the saw blade and over the workpiece to enable the user to follow the saw cut line (fig.4).
- 4.5.9. Holding the saw by the handle and support grip, move the saw forward to engage with the workpiece and saw in a straight line. The blade guard will open when the blade makes contact with the workpiece.
- × **DO NOT** force the saw sideways.
- 4.5.10. If the blade jams in the workpiece release the trigger immediately and withdraw it from the item once the blade is stationary.
- 4.5.11. Check that the blade guard closes when the saw is removed from the workpiece.
- 4.5.12. Always observe that the guard is covering the blade before placing the saw down on a bench or floor. An unprotected coasting blade will cause the saw to walk backwards, cutting whatever is in its path. Be aware of the time it takes for the blade to stop after the switch is released.

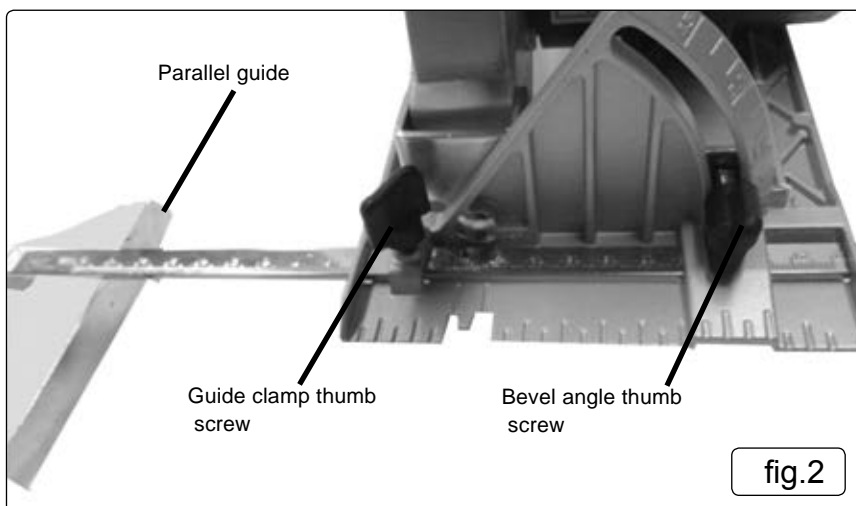

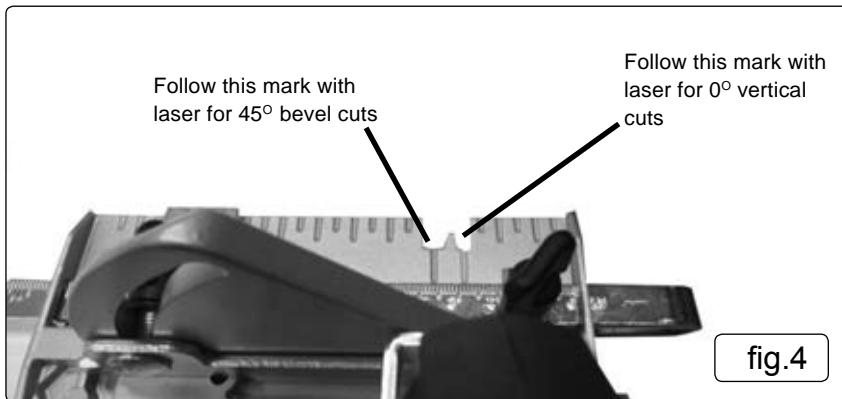
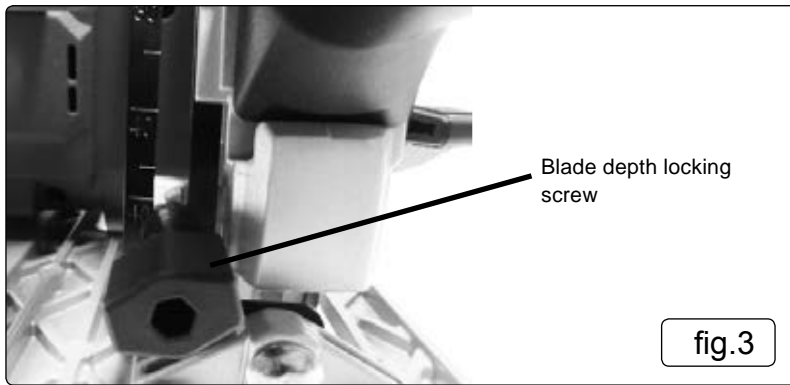

4.6. RIPPING

4.6.1. When ripping always use a rip fence or straight edge guide. This improves the accuracy of cut and reduces the chances of the blade binding.

4.7. KICKBACK CAUSES AND RELATED WARNINGS

NOTE:

Kickback is the sudden reaction to a pinched, bound or misaligned saw blade, causing an uncontrolled saw to lift up and out of the workpiece toward the operator.

When the blade is pinched or bound tightly by the cut (kerf) closing down, the blade stalls and the motor reaction drives the unit rapidly toward the operator.

If the blade becomes twisted or misaligned in the cut, the teeth at the back edge of the blade can dig into the top surface of the wood causing the blade to climb out of the cut (kerf) and jump back toward the operator.

Kickback is the result of saw misuse and/or incorrect operating procedures and can cause the saw to jump backwards. It can be avoided by taking proper precautions as given below.

- 4.7.1. Maintain a firm grip with both hands on the saw and position your arms to resist kickback forces. Position your body to either side of the blade but not in line with it. Kickback could cause the saw to jump backwards, but kickback forces can be controlled by the operator, if proper precautions are taken.
- 4.7.2. When the blade is binding or when interrupting a cut for any reason, release the trigger and hold the saw motionless in the material until the blade comes to a complete stop. Never attempt to remove the saw from the work or pull the saw backward while the blade is in motion or kickback may occur. Investigate and take corrective actions to eliminate the causes of blade binding.
- 4.7.3. When restarting a saw in the workpiece, centre the saw blade in the cut (kerf) and check that the saw teeth are not engaged in the material. If the saw blade is binding, it may walk up or kickback from the workpiece as the saw is restarted.
- 4.7.4. Support large panels to minimise the risk of blade pinching and kickback. Large panels tend to sag under their own weight. Supports must be placed under the panel on both sides, near the cut and near the edge of the panel.
- × **DO NOT** use dull or damaged blades. Unsharpened or improperly set blades produce a narrow cut (kerf) causing excessive friction, blade binding and kickback.
- 4.7.5. Blade depth and bevel adjustment locking mechanisms must be tight and secure before making a cut. If blade adjustments shift while cutting, it may cause binding or kickback.
- 4.7.6. Use extra caution when sawing into existing walls or other blind areas. The protruding blade may cut objects that can cause kickback or binding.

5. MAINTENANCE

- ☐ **WARNING!** Always ensure that the battery is removed before commencing any maintenance.
- 5.1. Check the safety guard operates correctly and freely and that all screws are tightening as required.
- 5.2. To prolong the useful life of the circular saw always clean it thoroughly after use and protect blade with a rust preventative.
- × **DO NOT** clean the plastic parts with any solvents as they may attack the plastic material. Clean the saw with a dry cloth and remove sawdust from ventilation slots.

WARNING! – Risk of Hand Arm Vibration Injury.

This tool may cause Hand Arm Vibration Syndrome if its use is not managed adequately.

This tool is subject to the vibration testing section of the Machinery Directive 2006/42/EC.
This tool is to be operated in accordance with these instructions.

Measured vibration emission value (a): 2.019 m/s²

Uncertainty value (k): 1.5 m/s²

Please note that the application of the tool to a sole specialist task may produce a different average vibration emission. We recommend that a specific evaluation of the vibration emission is conducted prior to commencing with a specialist task.

A health and safety assessment by the user (or employer) will need to be carried out to determine the suitable duration of use for each tool.

NB: Stated Vibration Emission values are type-test values and are intended to be typical.

Whilst in use, the actual value will vary considerably from and depend on many factors.

Such factors include; the operator, the task and the inserted tool or consumable.

NB: ensure that the length of leader hoses is sufficient to allow unrestricted use, as this also helps to reduce vibration.

The state of maintenance of the tool itself is also an important factor, a poorly maintained tool will also increase the risk of Hand Arm Vibration Syndrome.

Health surveillance.

We recommend a programme of health surveillance to detect early symptoms of vibration injury so that management procedures can be modified accordingly.

Personal protective equipment.

We are not aware of any personal protective equipment (PPE) that provides protection against vibration injury that may result from the uncontrolled use of this tool. We recommend a sufficient supply of clothing (including gloves) to enable the operator to remain warm and dry and maintain good blood circulation in fingers etc. Please note that the most effective protection is prevention, please refer to the Correct Use and Maintenance section in these instructions. Guidance relating to the management of hand arm vibration can be found on the HSC website www.hse.gov.uk - Hand-Arm Vibration at Work.



WEEE REGULATIONS

Dispose of this product at the end of its working life in compliance with the EU Directive on Waste Electrical and Electronic Equipment (WEEE). When the product is no longer required, it must be disposed of in an environmentally protective way. Contact your local solid waste authority for recycling information.



ENVIRONMENT PROTECTION

Recycle unwanted materials instead of disposing of them as waste. All tools, accessories and packaging should be sorted, taken to a recycling centre and disposed of in a manner which is compatible with the environment. When the product becomes completely unserviceable and requires disposal, drain any fluids (if applicable) into approved containers and dispose of the product and fluids according to local regulations.

Note: It is our policy to continually improve products and as such we reserve the right to alter data, specifications and component parts without prior notice.

Important: No Liability is accepted for incorrect use of this product.

Warranty: Guarantee is 12 months from purchase date, proof of which is required for any claim.

Sealey Group, Kempson Way, Suffolk Business Park, Bury St Edmunds, Suffolk. IP32 7AR



01284 757500



01284 703534



sales@sealey.co.uk



www.sealey.co.uk