



INSTRUCTION MANUAL

2200W ELECTRIC HORIZONTAL 6-TON LOGSPLITTER WITH GUARD

MODEL NO: THLS-6G -- PRODUCT NO: 1938181001

EN - ORIGINAL INSTRUCTIONS

ASSEMBLY REQUIRED – TWO PERSON LIFT

SAVE THESE INSTRUCTIONS

SPARES & SUPPORT: 01793 333212

FOR YOUR SAFETY

Please read & understand this manual, paying attention to the safety instructions, before use.

Incorrect use of the product could put the operator or machine in danger.

Whilst every effort has been made to ensure the accuracy of information contained in this manual, our policy of continuous improvement determines the right to make modifications without prior warning.

Images used are for illustration purposes only

Copyright Notice

Copyright © Handy Distribution

Permission is granted to reproduce this publication for personal & educational use only.

Commercial copying, redistribution, hiring or lending is prohibited.

No part of this publication may be stored in a retrieval system or transmitted in any other form or means without written permission from Handy Distribution.

In all cases this copyright notice must remain intact.

CONTENTS

SPECIFICATIONS

IMPORTANT INFORMATION

GENERAL SAFETY INSTRUCTIONS

SET UP & PREPARATION FOR OPERATION

KNOW YOUR MACHINE

OPERATION

CHECKING & REPLACING HYDRAULIC OIL

TROUBLE SHOOTING

MAINTENANCE & STORAGE

WIRING & HYDRAULIC SYSTEM DIAGRAMS

EC DECLARATION OF CONFORMITY

PARTS DIAGRAM & LIST

WARRANTY

NOTES

ASSEMBLY IS REQUIRED – TWO PERSON LIFT

This product requires assembly before use. See the “Assembly” section for instructions.

Please check that all parts required for the assembly of this spreader are included. If for any reason you believe a part for the assembly is missing or damaged, please contact us.

If you require any assistance with regards to the contents or operation of your machine, please contact us:

TEL: 01793 333212

**EMAIL: customerservice@handydistribution.co.uk
(MON – FRI 8.00AM TO 5.30PM EXCL. BANK HOLIDAYS)**

SPECIAL WARNINGS & INSTRUCTIONS

- The splitting operation of the machine is designed to be activated by one person. While there is the possibility that additional operators could be working with the machine (e.g. for loading and unloading), only one operator should activate splitting operations;
- The machine shall not be used by children;
- Description of functional tests of the machine;
- The installation and maintenance requirements including a list of those devices e.g. two-hand control device which should be verified, how frequently the verification shall be carried out and by what method;
- Do not remove jammed logs with your hands. Never use another person to help you with freeing jammed logs. Push the wedge until the log is split open.

SPECIFICATIONS

The manufacturer reserves the right to change the product specification and livery according to continued product improvements.

Model Number	THLS-6G
Product Number	1938181001
Motor*	(220-240V ~50Hz 9.6A), 2200W, S3 25%,
Splitting Force	6 Ton
Forward Speed	3.08cm/s
Retract Speed	5.29cm/s
Hydraulic Pressure	20.8 Mpa
Hydraulic Oil Tank Capacity	3.5L
Hydraulic Oil	Type 22
Stroke Length (mm)	370
Log Capacity Diameter (mm)**	Min 50 – 250 Max
Log Capacity Length (mm)	Min 200 – 520 Max
Overall Size (cm)	L 116, W 42.5, H 61
Weight (kg)	N.W 59 – G.W 63
Noise Pressure Level (LpA)	78.8 dbA under no load; 89.8 dbA under full load
Vibration	< 2.5 m/s ²

* S3 25%, Intermittent periodic duty: time of one load cycle is 10 minutes, operation time at constant load is 2.5 minutes, de-energized and at rest is 7.5 minutes.

** The diameter of the log is not the only factor that determines how easy it will be to split. A small log can be difficult to split when it has knots or is a particularly hard wood.

IMPORTANT INFORMATION

HYDRAULIC OIL

This machine is supplied with hydraulic oil from the factory, to allow the machine to be used straight from the carton following assembly. Do check the oil level (instructions available in the manual) prior to the first use and periodically thereafter. Type 22 hydraulic oil is recommended.

ELECTRICAL REQUIREMENTS

Connect the main leads to a standard 220-240V±10% (50Hz±1Hz) electrical supply which has protection devices of under-voltage, over-voltage, over-current as well as a residual current device (RCD) which maximum residual current rated at 0.03A.

EXTENSIONS LEADS

Improper use of extension cords may cause inefficient operation of the logsplitter which can result in overheating. Be sure the extension cord is no longer than 10m and its section is no less than 2.5mm² to allow sufficient current flow to the motor. Avoid use of free and inadequately insulated connections. Connections must be made with protected material suitable for outdoor use.

WORKING CONDITIONS

















This log splitter is for domestic use only (commercial usage will reduce the warranty period of the machine – see warranty pages for details). It is designed for operating under ambient temperatures between +5°C and 40°C and for installation at altitudes no more than 1000m above M.S.L. The surrounding humidity should be less than 50% at 40°C. It can be stored or transported under ambient temperatures between -25°C and 55°C.

INSPECT YOUR LOG

Make sure there are no nails or foreign objects in logs to be split. The ends of the logs must be cut square. Branches must be cut off entirely so that the trunk is relatively smooth.

GENERAL SAFETY INSTRUCTIONS

It is important that you read and understand the owner's manual and labels affixed to the machine. Learn its application and limitations as well as the specific potential hazards. Retain these instructions for future reference. The operator is responsible for following the warnings & instructions in this manual and on the product.

	Read & understand operator's manual before using the machine. Failure to follow instructions could result in death or serious injury.		DANGER Keep clear of all moving parts.
	Wear protective gloves to protect your hands		Do not remove jammed logs with your hands
	Whenever the machine is in use, eye protection must be worn to safeguard against flying objects. Hearing protection must also be used to protect the operators hearing.		Before making adjustments, changing parts, cleaning, or working on the log splitter, always disconnect the power. Consult the technical manual before servicing.
	Wear protective footwear		Dispose of all oil at an authorised collection point or follow the local stipulations that apply where the log splitter is being used. Dispose of used oil in an environmentally friendly way.
	Check your logsplitter before turning it on. Keep guards in place and in working order. Replace damaged, missing or failed parts before using it.		Keep all bystanders & animals at least 10 metres away from the machine during operation. If approached, stop the machine immediately.
	Do not use in the rain.		WARNING Stay clear of moving parts.
	Safety alert symbol. Used to alert you to potential personal injury hazards. Obey all safety messages that follow this symbol to avoid possible injury.		Indicates an imminently hazardous situation which, if not avoided, will result in serious injury.
	Indicates a potentially hazardous situation which, if not avoided, could result in serious injury		Indicates a potentially hazardous situation which, if not avoided, may result in minor or moderate injury.
CAUTION	Used without the safety alert symbol indicates a potentially hazardous situation which, if not avoided, may result in property damage.		

STAY ALERT

Do not operate the machine while under the influence of drugs, alcohol, or any medication that could affect your ability to use it properly. Do not use this machine when you are tired or distracted from the job at hand. Always be aware of what you are doing at all times. Use common sense.

AVOID DANGEROUS CONDITIONS

We do not recommend using the logsplitter on the ground for operation. This is an awkward operating position, bringing the operators face close to the machine, and thus risking being struck by wood chips or debris. Put the logsplitter on a 72-85 cm high, stable, flat, and level work bench where there is plenty of room for handling, and help the operator stay alert. Bolt the logsplitter to the work surface if it tends to slip, walk, or slide. Keep your work area clean and well light. Cluttered areas invite injuries. Do not use the logsplitter in wet or damp areas or expose it to rain. Do not use it in areas where fumes from paint, solvents or flammable liquids pose a potential hazard.

INSPECT YOUR MACHINE

Check your logsplitter before turning it on. Keep guards in place and in working order. Form a habit of checking tools are removed from the working area before turning it on. Replace damaged, missing or failed parts before operating the machine.

DRESS PROPERLY

Do not wear loose clothing, gloves, neckties or jewellery (rings, wrist watches). They can be caught in moving parts. Protective electrically nonconductive gloves and non-skid footwear are recommended when working. Wear protective hair covering to contain long hair, preventing it from getting caught in machinery.

PROTECT EYES & FACE

Any logsplitter may throw foreign objects into the eyes. This can cause permanent eye damage. Always wear safety goggles. Everyday eye-glasses have only impact resistant lenses. They are not safety glasses.

We do not recommend using the logsplitter on the ground for operation. This is an awkward operating position, bringing the operators face close to the machine, and thus risking being struck by wood chips or debris.

AVOID ELECTRICAL SHOCK

Check that the electric circuit is adequately protected and that it corresponds with the power, voltage and frequency of the motor. Check that there is a ground connection and a regulation differential switch upstream. Ground the logsplitter. Prevent body contact with grounded surfaces: pipes, radiators, ranges, and refrigerator enclosures. Never open the switch box on the motor. Should this be necessary, contact a qualified electrician. Make sure your fingers do not touch the plug's metal prongs when plugging or unplugging the logsplitter.

KEEP BYSTANDERS AND CHILDREN AWAY

The logsplitter must be always operated by one person only. Other people should keep a safe distance from the work area (10 metres recommended), especially when the logsplitter is under operation. Never use another person to help you with freeing a jammed log.

INSPECT YOUR LOG

Make sure there are no nails or foreign objects in logs to be split. The ends of the logs must be cut square. Branches must be cut flush with the trunk.

DO NOT OVERREACH

The operating floor must not be slippery. Always keep proper footing and balance. Never stand on the logsplitter. Serious injury could occur if the tool is tipped or if the cutting tool is unintentionally contacted. Do not store anything above or near the logsplitter where anyone might stand on the tool to reach them.

AVOID INJURY FROM UNEXPECTED ACCIDENT

Always pay full attention to the movement of the log pusher. Do not attempt to load the log on until the log pusher has stopped. Keep hands out of the way of all moving parts.

PROTECT YOUR HANDS

Keep your hands away from splits and cracks which open in the log; They may close suddenly and crush or amputate your hands or fingers. Do not remove jammed logs with your hands.

DO NOT FORCE TOOL

It will do a better and safer job at its designed rate. Never try to split logs larger than those indicated in the specifications table. This could be dangerous and may damage the machine. Don't use the logsplitter for a purpose for which it was not intended.

NEVER LEAVE MACHINE RUNNING UNATTENDED

Do not leave the machine unattended, until it has come to a complete stop and the power removed from the electrical source.

DISCONNECT POWER

Unplug from the electrical supply when not in use, before adjusting, changing parts, cleaning or working on the logsplitter. All servicing and repairs are recommended to be undertaken by an approved service dealer.

MAINTAIN YOUR MACHINE WITH CARE

Clean the machine immediately after use. Keep the machine clean to ensure it operates to its full & safest performance. When maintaining this machine, only the manufacturer's original replacement parts should be used. The use of non-original manufacturer parts may invalidate your warranty.

PROTECT THE ENVIRONMENT

Take used oil to an authorised collection point or follow the stipulations in the country where the logsplitter is used. Do not discharge into drains, soil or water.

STORE IDLE EQUIPMENT

When not in use, the machine should be stored in a dry location. Keep the machine away from children and others not qualified to use it.



This symbol on the product or on its packaging indicates that this product may not be treated as household waste. Instead it shall be handed over to the applicable collection point for the recycling of electrical and electronic equipment.

For more detailed information about recycling of this product, please contact your local council office, your household waste disposal service or shop where you purchased the product.

SET UP & PREPARATION FOR OPERATION

Familiarise yourself with the assembly components of this log splitter. If you believe you are missing any components, please contact us:

TEL: 01793 333212 or EMAIL: customerservice@handydistribution.co.uk

(MON – FRI 8.00AM TO 5.30PM EXCL. BANK HOLIDAYS)

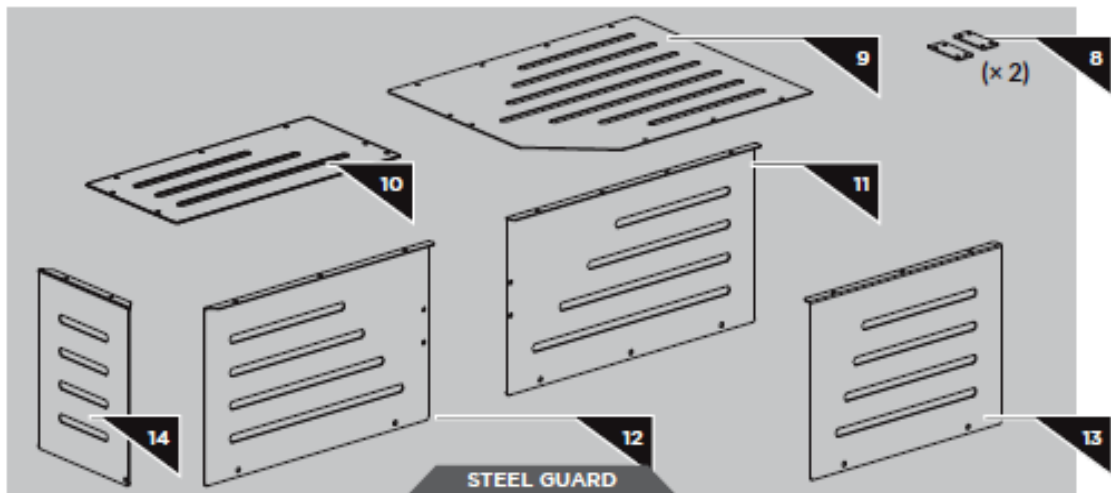
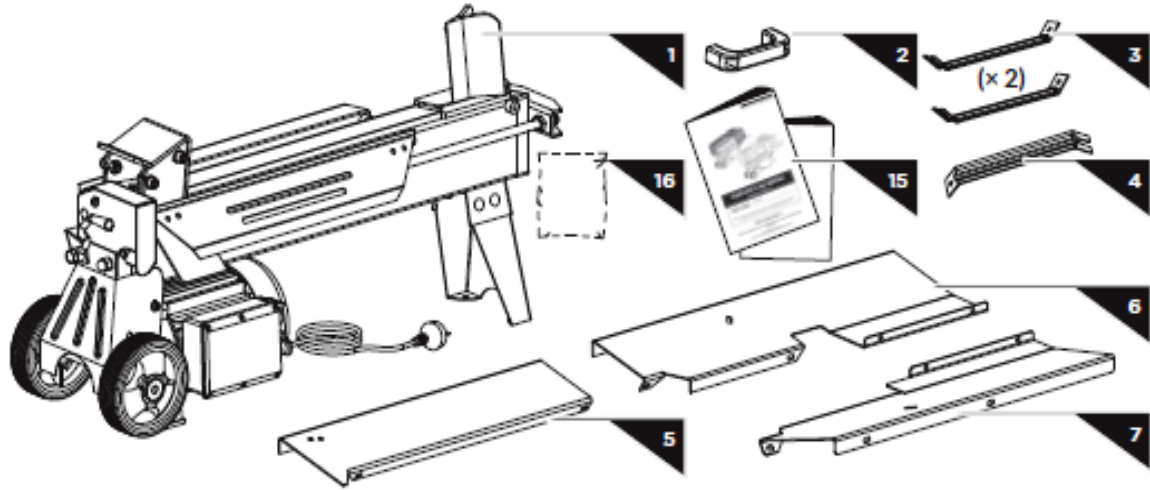

- | | | |
|-------------------------|-------------------------|------------------------|
| 1. Log Splitter Frame | 6. Log Tray A | 11. Rear Guard Plate A |
| 2. Transport Handle | 7. Log Tray B | 12. Rear Guard Plate B |
| 3. Support Strut A (x2) | 8. Plate Connector (x2) | 13. Front Guard Plate |
| 4. Support Strut B | 9. Top Guard Plate A | 14. Left Guard Plate |
| 5. Guard Bottom Plate | 10. Top Guard Plate B | |

	M6 x 16	x 2	A
	M6 x 12	x 1	B
	M6 x 12	x 2	
	M6 x 12	x 1	C
	M6 x 12	x 1	
	M6 x 12	x 1	D
	M6 x 12	x 1	
	M6 x 12	x 2	E
STEEL GUARD			
	M6 x 12	x 8	F
	M5 x 12	x 20	G

Fixing Kit Contents

ASSEMBLY

LIFTING HANDLE

Mount the lifting handle to the U bracket with two M6×16 bolts.

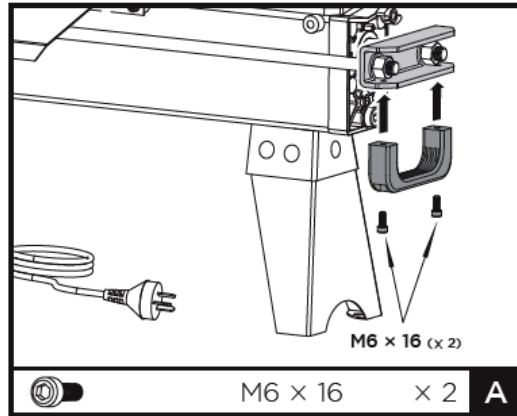

LOG TRAY

1. Mount the guard bottom plate to the rear guiding plate and secure with two M6×12 socket head cap screws and locknuts. Loosen the socket head cap screw and big washer on the wheel bracket, insert the open end of support strut B between the big washer and wheel bracket and tighten screw. Connect the upper end of support strut B to the guard bottom plate with cross recessed pan head screw M6×12 and locknut M6 and then tighten it.

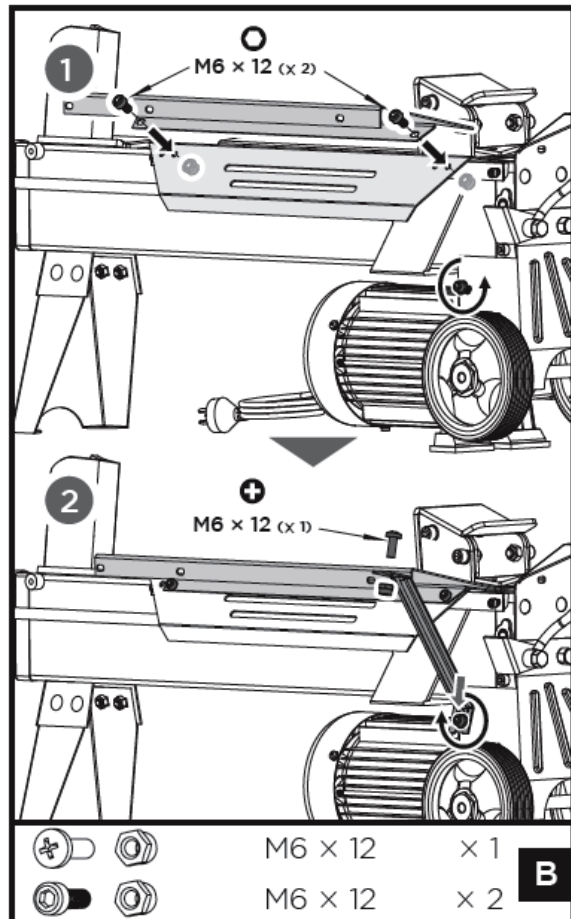

- Align the two mounting holes of the log tray A to the holes on rear side of the splitter. Insert one socket head cap screw M6×12 and spring washer 6 into the mounting hole on left side and the other socket head cap screw M6×12 and locknut M6 on right side and securely tighten both.

Loosen the cup head bolt and nut on left side of the front leg, insert the open end of support strut A onto the bolt and then tighten the nut. Connect the upper end of support strut A to log tray A with cross recessed pan head screw M6×12 and locknut M6 and then tighten it.

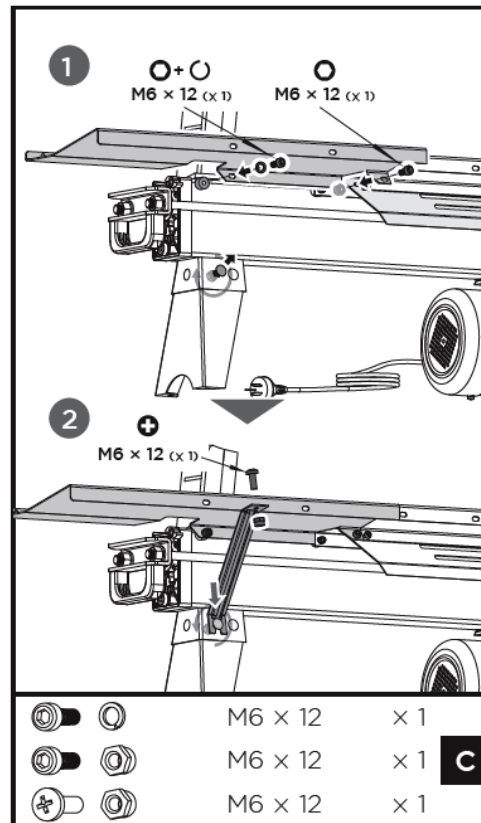

- Align the two mounting holes of the log tray B to the holes on front side of the splitter. Insert one socket head cap screw M6×12 and spring washer 6 into the mounting hole on right side and the other socket head cap screw M6×12 and locknut M6 on left side and securely tighten both.

Loosen the cup head bolt and nut on right side of the front leg, insert the open end of support strut A onto the bolt and then tighten the nut. Connect the upper end of support strut A to the log tray B with cross recessed pan head screw M6×12 and locknut M6 and then tighten it.

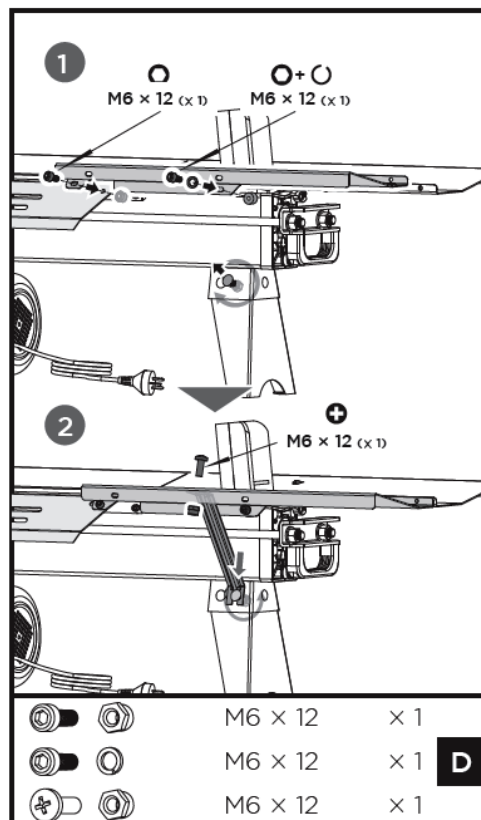

4. Connect log tray A and log tray B with two M6×12 screws and locknuts.

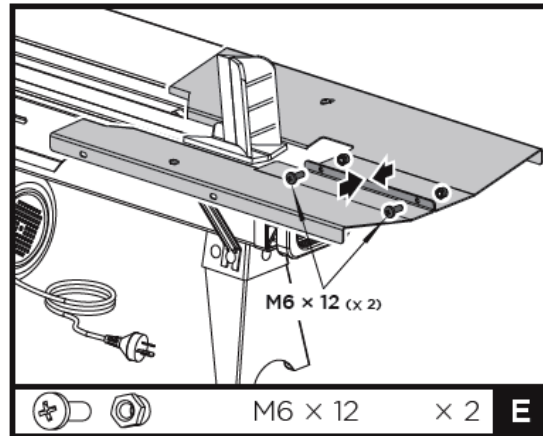

STEEL GUARD

1. Attach the front guard plate, left guard plate and two rear guard plates to the log tray and bottom plate with M6×12 bolts and nuts.

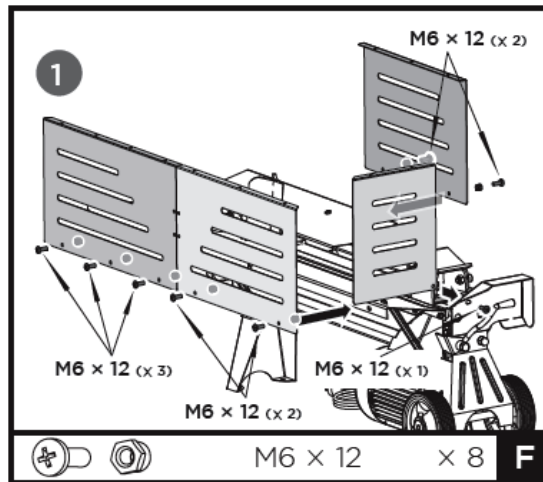

2. Mount the two top guard plates to the vertical plates with M5×12 bolts and nuts.
3. Connect two top guard plates / rear guard plates with the plate connectors and M5×12 bolts and nuts.

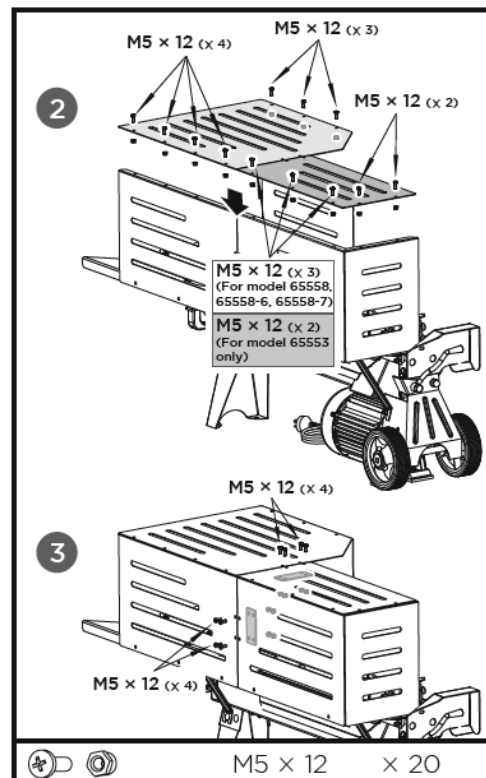

KNOW YOUR MACHINE

Make yourself aware of the components and operational levers of the machine, prior to attempting any work.

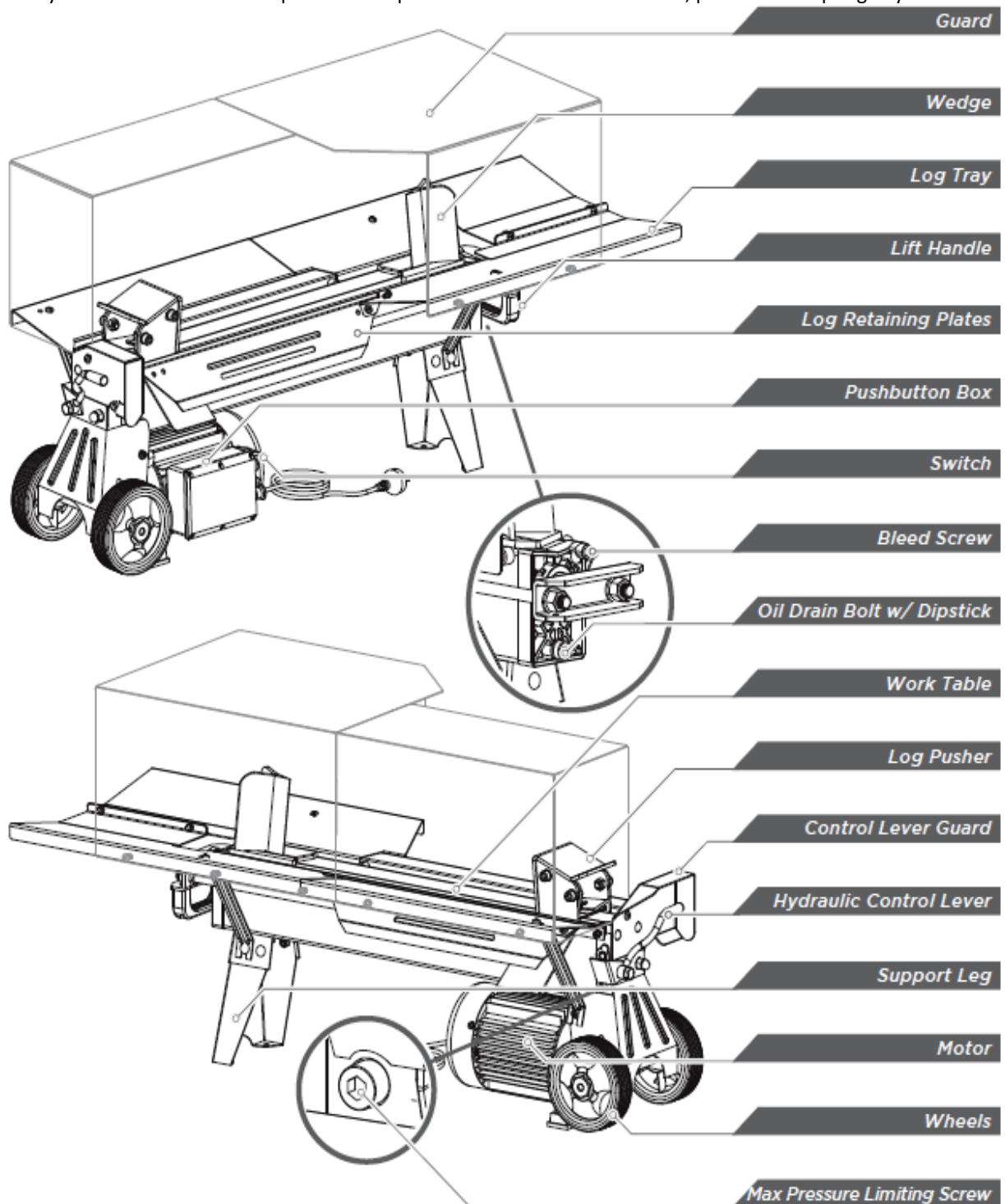

BLEED SCREW IMPORTANT

Before operating the logsplitter, the Bleed Screw should be loosened a few rotations until air can go in and out of the oil tank smoothly. Air flow through the Bleed Screw hole should be noticeable while the logsplitter is working. Before moving the logsplitter, ensure the Bleed Screw is tightened to avoid oil leaks.



FAILURE TO LOOSEN THE BLEED SCREW WILL KEEP THE SEALED AIR IN HYDRAULIC SYSTEM COMPRESSED. SUCH CONTINUOUS AIR COMPRESSION WILL BLOW OUT THE SEALS OF THE HYDRAULIC SYSTEM AND CAN CAUSE PERMANENT DAMAGE TO THE LOG SPLITTER, WHICH IS NOT COVERED UNDER THE TERMS & CONDITIONS OF THE MANUFACTURERS WARRANTY.

MAX PRESSURE LIMITING SCREW



DO NOT ADJUST THE MAX PRESSURE LIMITING SCREW!

Max pressure was set before the log splitter ex work and the max pressure limiting screw is sealed with glue to ensure the log splitter works under pressure no more than 6 tons.

The setting was done by qualified mechanic with professional instruments.

Unauthorized resetting will cause the hydraulic pump fail to output enough splitting pressure or RESULT IN SERIOUS INJURY AS WELL AS DAMAGE TO THE MACHINE .

TRANSPORTING YOUR LOGSPLITTER

The logsplitter is equipped with 2 wheels for minor moving. To move the logsplitter to the work site. Grip the handle to tilt the logsplitter slightly after making sure the oil tank cover is tightened.

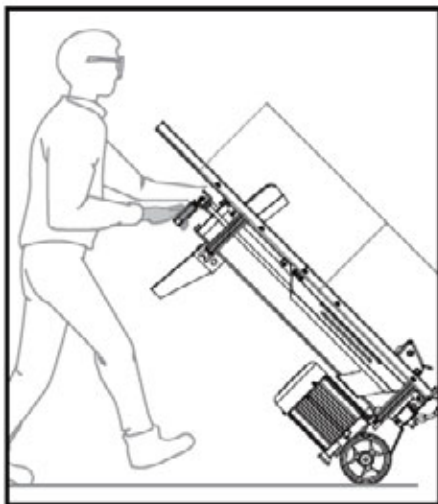

DO NOT TRANSPORT THE LOGSPLITTER WITH WOOD LOADED

OPERATION



WARNING

The safety guard supplied with this log splitter has been done so to protect the user from debris. Using the log splitter without the guard positioned or closed correctly, could cause serious damage to the user and bystanders. Enclose the log at all times.

APPLICATION CONDITIONS

This log splitter is a home use model. It is designed for operating under ambient temperatures between +5°C and 40°C and for installation at altitudes no more than 1000m above

M.S.L. The surrounding humidity should be less than 50% at 40°C. It can be stored or transported under ambient temperatures between -25°C and 55°C. Before operation, put the log splitter on a 72-85 cm high, stable, flat, and level work bench. Fix the support leg using two bolts M8×35(A) onto a suitable work table/bench.

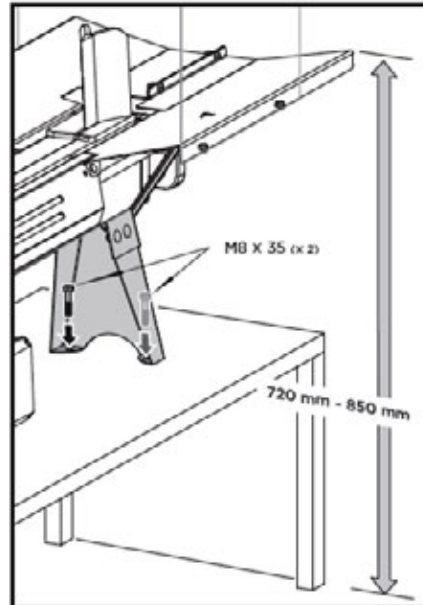

SPLITTING – TWO HAND OPERATION

This log splitter is equipped with a “ZHB” control system that must be operated with both hands – the left hand controls the hydraulic control lever, while your right hand controls the push button switch. The log splitter will freeze if either hand is removed.

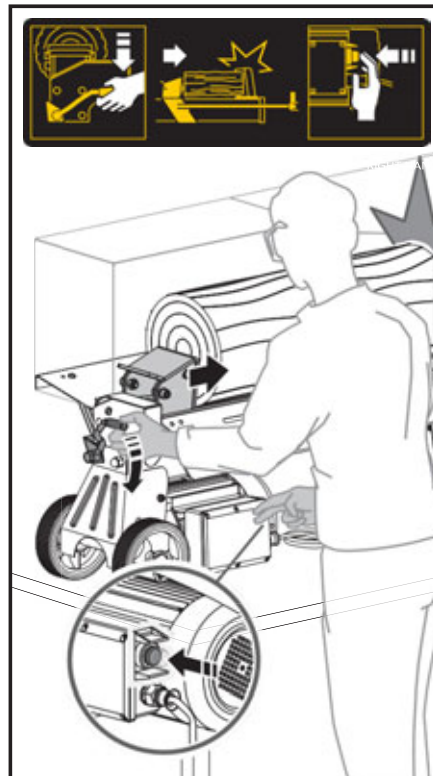

The log pusher will only start to return backwards to the starting position after both hands release the controls. During use the log pusher will move towards the splitting wedge putting pressure on the log.

The trigger type lockout device is used to avoid accidental Hydraulic Control Lever activation. To operate the Hydraulic Control Lever, draw the Trigger backward with your index finger before pushing the Hydraulic Control Lever forward.

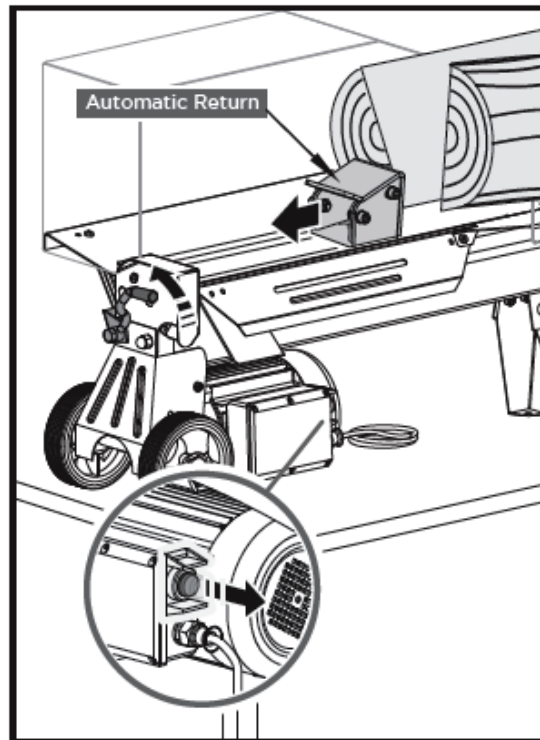

Never force the log splitter for more than 5 seconds. Do not keep pressure on it to split excessively hard wood.

After 5 seconds of constant use, the oil under pressure will be overheated and the machine could be damaged. For such extremely hard logs, rotate it by 90° to see whether it can be split in a different direction (the log should still be split with the grain as shown in the diagrams in this manual). In any case, if you are not able to split the log, this means that its hardness exceeds the capacity of the machine and thus that log should be discarded to protect the log splitter.

Always set logs firmly on the log retaining plates and work table. Make sure that the log will not twist, rock or slip while being split. Do not force the blade by splitting the log on the upper part of the wedge (as shown in the diagram). This will break the blade or damage the machine.

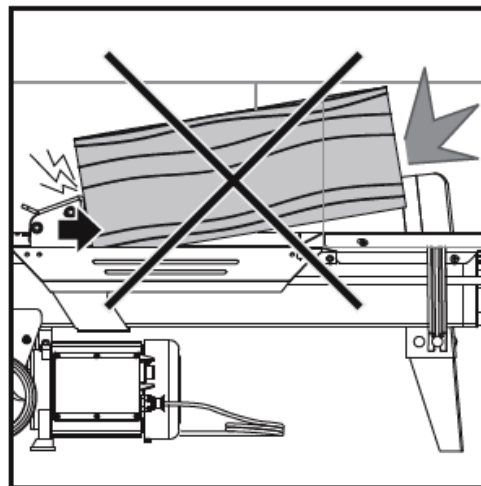

Break the log in the direction of its growing grain. Do not place log across the log splitter for splitting. It may be dangerous and may seriously damage the machine.

Do not attempt to split 2 pieces of logs at the same time. One of them may be thrown by the machine which could cause serious injuries to the user.



DANGER

Keep you hands away from the splitting area, live area and heating area while working!

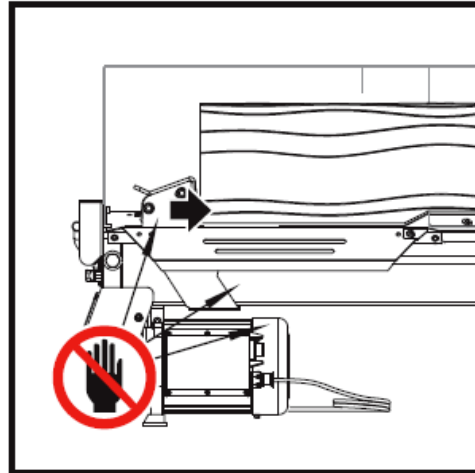

FREING A JAMMED LOG

- Release both controls.
- After the log pusher moves back and completely stops at its starting position, insert a wedge of wood under the jammed log.
- Start the logsplitter to push the wedge wood and go completely under the jammed log.
- Repeat above procedure with sharper sloped wedges of wood until the log is completely freed.

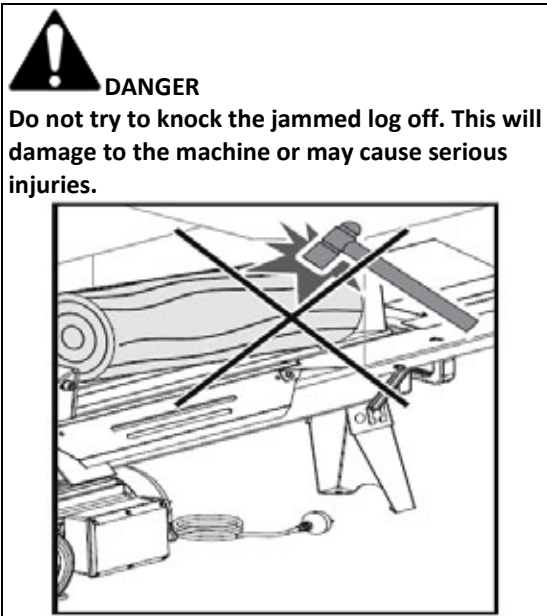
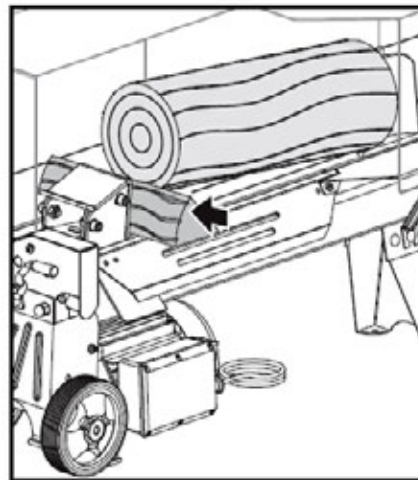

DANGER

Do not try to knock the jammed log off. This will damage to the machine or may cause serious injuries.

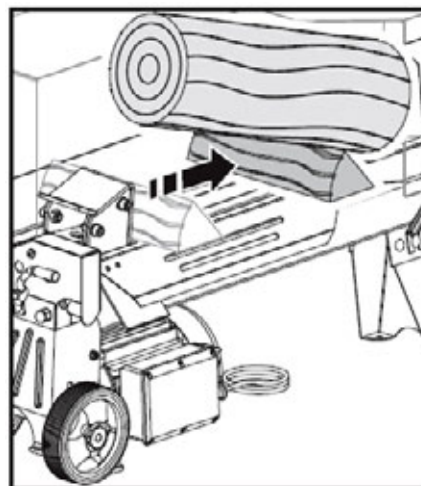

SHARPENING THE SPLITTING WEDGE

This logsplitter is equipped with a reinforced splitting wedge which is specially treated. After long periods of operation, and when required; sharpen the wedge using a fine-toothed file removing any burrs or flat spots on the edge.

RAM ADJUSTMENT

The logsplitter is fitted with a Ram Adjustment Knob which reduces any unnecessary movement of the ram, allowing for quicker and more efficient use of the tool.

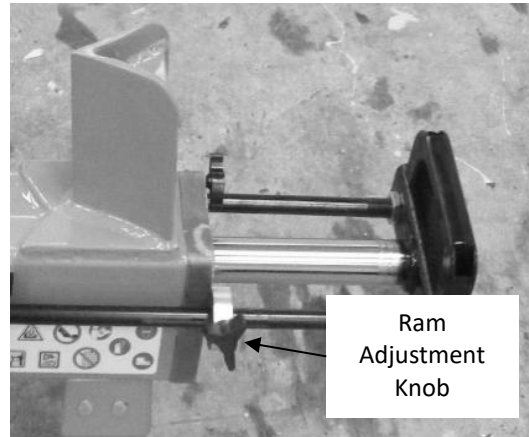

WARNING

When adjusting the ram movement, do not put your hands between the hand knob and the log splitter mechanism, as accidental release of the Control Handle would cause the returning hand knob and handle to trap and crush your hand against the splitter.

- To adjust the ram movement, first undo the hand knob.
- Then without a log on the work table depress the Control Handle and the start button.
- When the gap between the ram and the splitting wedge is the intended size, release the start button, but continue to hold the Control Handle to keep the ram in place.
- Slide the hand knob along the pipe to set the gap size. The closer you move the Ram Adjustment Knob towards the log splitter, and the more you slide it down the pipe, the smaller the gap will be left between the ram and the splitting wedge.
- If the gap is correct you should place the hand knob against the log splitter.
- If the gap is too small you can leave an equivalent space between the knob and the log splitter so that the ram returns further back.
- If the gap is too small, you will have to press the start button to reduce it before setting the Ram Adjustment Knob.
- Once you have set the hand knob at the desired position, retighten it to adjust the movement of the ram.
- Make sure that your hand is clear of the hand knob area. You can now release the Control Handle. The ram should now return to the desired position whenever you release the start button and Control Handle. You can repeat these steps if further adjustment is required.



CHECKING & REPLACING HYDRAULIC OIL

CHECKING HYDRAULIC OIL LEVEL

Periodically check the oil level to ensure it is between the 2 grooves around the Dipstick. To check the oil.

- Stand the machine up at the wheel end.
- Using an 8mm Allen Key, unscrew the Dipstick & remove it.
- If the oil level is lower than the minimum (min) bottom mark on the dipstick refill with Type 22 Hydraulic oil and check the level again, until the oil level reaches the maximum (max) mark on the dipstick.

The following hydraulic oils or equivalent Type 22 are recommended for the log splitter's hydraulic transmission system:

- **HANDY PARTS** Logsplitter Oil WPL110 (1L), WPL113 (5L)
 - **SHELL** Tellus 22
 - **MOBIL** DTE 11
 - **ARAL** Vitam GF 22
 - **BP** Energol HLP-HM 22
-
- Clean the Dipstick and put it back into the oil tank while keeping the log splitter held upright.
 - Never exceed the maximum level. Empty oil if the maximum level is exceeded until the oil level is between the minimum & maximum marks on the dipstick.
 - The machine will operate as designed with oil in between the minimum & maximum marks.
 - Clean the Oil Drain Bolt before replacing it. Make sure they are tightened to avoid leaks before lowering the logsplitter back to a horizontal position.

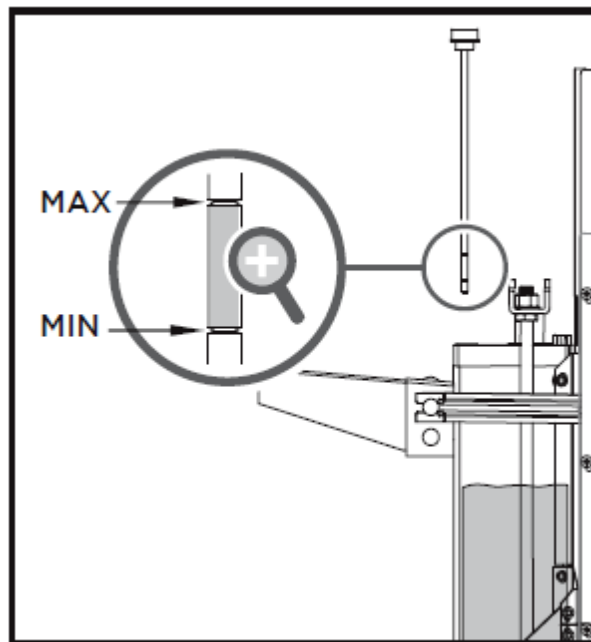

HYDRAULIC OIL	THLS-6
Total capacity	5.2 Litres
Max amount of oil needed to reach top mark of dipstick	2.4 Litres
Min amount of oil needed to reach lower mark of dipstick	3.1 Litres



Read dipstick to determine the maximum and minimum of the oil level. Low oil can damage the oil pump. Overfilling can result in excessive temperature in the hydraulic transmission system.

REPLACING HYDRAULIC OIL

The logsplitter is supplied with a full hydraulic oil tank; however, you should check if hydraulic oil needs to be added in case of leakage during transit, prior to your first operation.

You should also replace the hydraulic oil in the logsplitter after every **150 hours** of use.

Follow the steps below to check and replace hydraulic oil.

- Make sure all moving parts stop and the logsplitter is unplugged.
- Using an 8mm Allen Key, unscrew the dipstick & remove it.
- Tip the logsplitter onto the front support leg, over a minimum 4 litre capacity container to drain the hydraulic oil off.
- Examine oil for metal chips as a precaution to future problems.
- Refill with fresh hydraulic oil as per the hydraulic oil specifications below.

The following hydraulic oils or equivalent Type 22 are recommended for the log splitter's hydraulic transmission system:

- **HANDY PARTS Logsplitter Oil WPL110 (1L), WPL113 (5L)**
 - **SHELL Tellus 22**
 - **MOBIL DTE 11**
 - **ARAL Vitam GF 22**
 - **BP Energol HLP-HM 22**
-
- Clean the Dipstick and put it back into the oil tank while keeping the log splitter held upright.
 - Never exceed the maximum level. Empty oil if the maximum level is exceeded until the oil level is between the minimum & maximum marks on the dipstick.
 - The machine will operate as designed with oil in between the minimum & maximum marks.
 - Clean the Oil Drain Bolt before replacing it. Make sure they are tightened to avoid leaks before lowering the logsplitter back to a horizontal position.

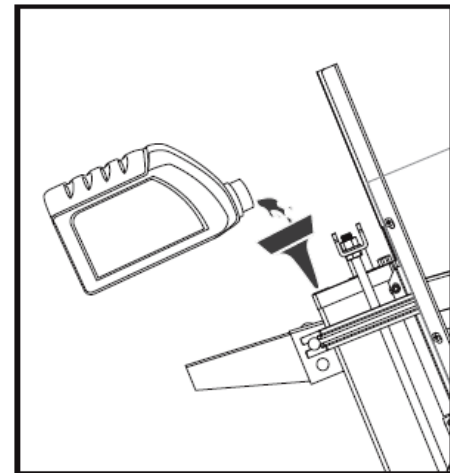
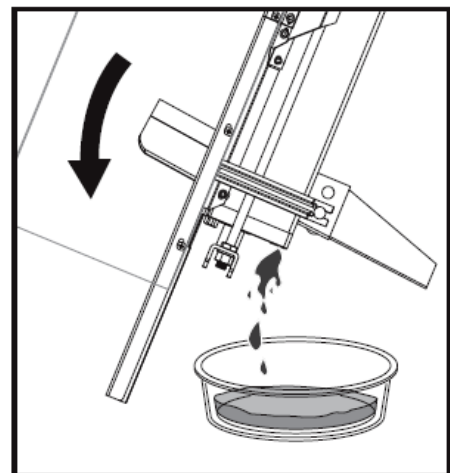
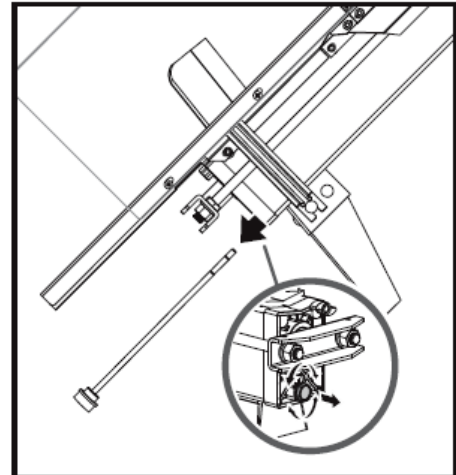

TROUBLE SHOOTING

PROBLEM	PROBABLE CAUSE	REMEDY SUGGESTED
Fails to split logs	Log is improperly positioned	Refer to "Operation" section for perfect log loading.
	The sizes or hardness of the log exceeds the capacity of the machine	Reduce the log sizes before splitting it on the log splitter.
	Wedge cutting edge is blunt	Refer to "Sharpening Wedge" section to sharpen the cutting edge.
	Oil leaks	Locate leak(s) and contact the dealer.
	Unauthorised adjustment was made on Max. Pressure Limiting Screw. Lower max pressure rating was set.	Contact an approved service dealer.
The log pusher moves jerkily, making unfamiliar noise or excessive vibration	Lack of hydraulic oil and excessive air in the hydraulic system.	Check oil level for possible oil refilling. Contact an approved service dealer.
	Excessive air in the hydraulic system.	Purge the hydraulic system. Remove the air bleed screw. Operate the ram 5 or 6 times without a log in place. Return the bleed screw to open position and split the log. If the problem continues contact the local approved service dealer.
Motor running, ram not moving	Incorrect specification extension lead	Be sure the extension lead is no longer than 10m and its cross-section is no less than 2.5mm ² to allow enough current flow to the motor.
Oil leaks around the cylinder ram or from other points.	Air sealed in the hydraulic system while operating.	Loosen the Bleed Screw by 2 or 3 rotations to open position, do not remove, before operating the log splitter
	Bleed Screw was not tightened before moving the log splitter.	Tighten the Bleed Screw fully after use and before moving.
	The Oil Drain Bolt with Dipstick is not tight.	Tighten the Oil Drain Bolt with Dipstick with 8mm Allen Key.
	The Hydraulic Control Valve Assembly and / or seal(s) are worn	Contact the local Approved Dealer

MAINTENANCE & STORAGE

Always ensure the Bleed Screw is fully tightened when the machine is not in use.

When not in use, the machine should be stored in a dry location. Keep away from direct sunlight.

Keep the machine away from children and others not qualified to use it. Avoid direct sunlight.

Do not store anything above or near the machine, where anyone might stand on the machine to reach them.

WIRING & HYDRAULIC SYSTEM DIAGRAMS

WIRING DIAGRAM

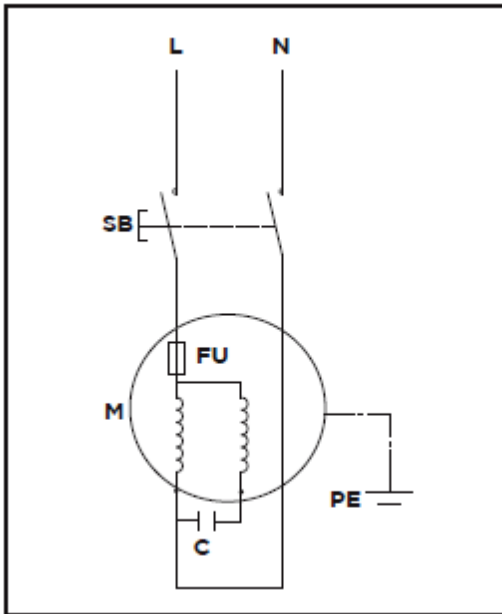

HYDRAULIC DIAGRAM

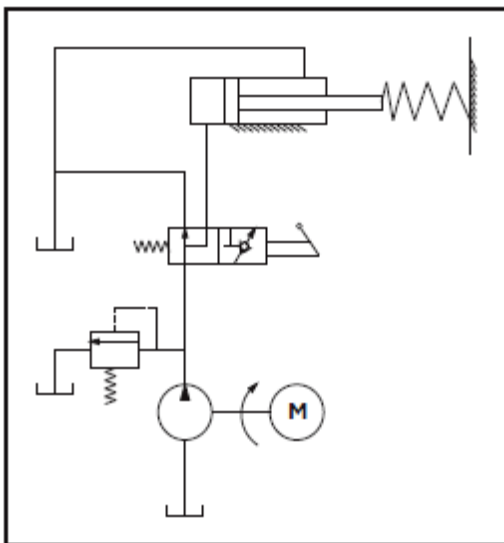



EC DECLARATION OF CONFORMITY

We Handy Distribution Ltd - SN3 5HY (Importer) declare that the product:

Designation: Horizontal Electric 6 Ton Log Splitter with Guard

Model(s): THLS-6G

Product Number: 1938181001

Type/Serial No: As per rating label on machine

Motor Wattage: 2200

Complies with the following directives:

2006/42/EC – Machinery Directive

The conformity assessment procedure followed was in accordance with

EN 609-1:2017, EN 60204-1:2006+A1 :2009+AC:2010

Notified Bodies:

TÜV Rheinland LGS Products GmbH

Address(es):

Tillystrabe 2 – 90431 Nürnberg

Authorised signatory & technical file holder

Date:

01/09/2018

Signature:

A handwritten signature in black ink, appearing to read 'S Belcher', written over a horizontal line.

Name:

Mr. Simon Belcher

Position:

Chairman

Company:

Handy Distribution Ltd

Address:

Murdock Rd, Dorcan, Swindon, Wiltshire, SN3 5HY.

PARTS DIAGRAM – THLS-6G (1938181001)

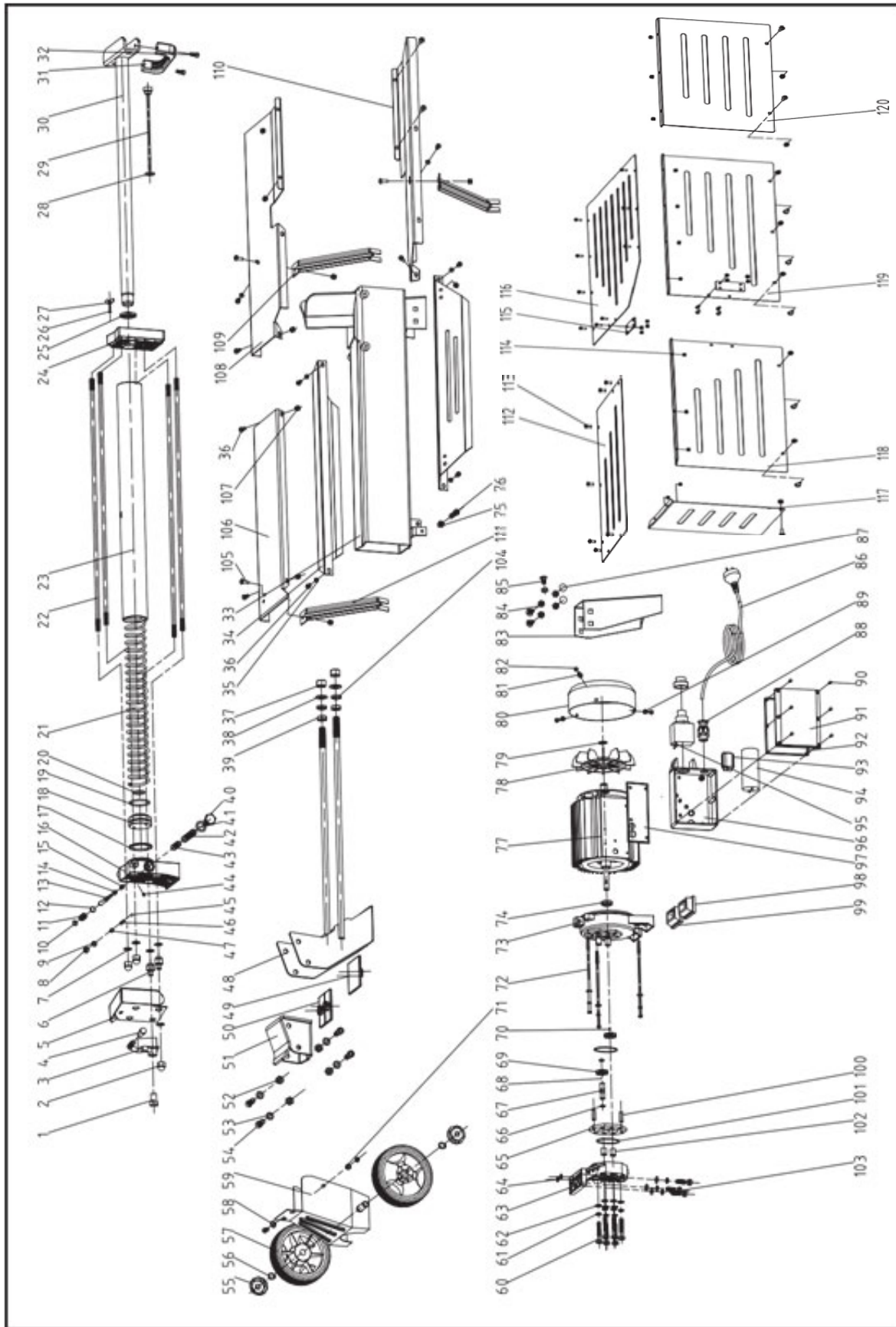

PARTS LIST – THLS-6G (1938181001) – Pt 1

Item No.	Handy Part No	Description	Qty
1	TH114-38	Lever Mount Nut	1
2	TH244-1	Cap Nut M10	3
3	TH114-36	Lever	1
4	TH114-37	Lever Knob	1
5	TH244-2	Lever Guard	1
6	TH114-35	Customized Nut	2
7	TH114-28	Copper Gasket 10	4
8	TH155-8	Safety Valve Bolt M8	1
9	TH155-9	O-ring 5.5x2	1
10	TH155-10	Snap Washer 6	1
11	TH155-11	Valve Retract Spring	1
12	TH114-32	O-ring 6x1.5	1
13	TH114-43	Valve Core Rod	1
14	TH155-14	Sliding Pressure Sensor Sleeve	1
15	TH155-15	Sliding Pressure Sensor Sleeve Spring	1
16	TH114-27	Aluminium Cover (Rear)	1
17	TH114-26	O-ring 54.5x2.65	1
18	TH114-3	Piston	1
19	TH114-2	Piston Ring 60	1
20	TH114-4	O-ring 32x3.5	1
21	TH114-5	Spring	1
22	TH114-15	Stud Bolt	4
23	TH114-1	Hydraulic Cylinder	1
24	TH114-61	Aluminium Cover (Front)	1
25	TH114-12	Piston Rod Seal 30	1
26	TH114-14	O-ring 7x1.9	1
27	TH114-13	Wing Bolt M5x12	1
28	TH114-62	Washer Groupware 14	1
29	TH114-63	Dipstick	1
30	TH244-3	Piston Rod	1
31	TH114-9	Lift Handle	1
32	TH114-10	Screw M6x16	2
33	TH244-4	Frame Tube	1
34	TH244-5	Lead Plank	2
35	TH114-17	Spring Washer 6	6
36	TH114-16	Screw M6x12	12
37	TH114-11	Nut M14	2
38	TH114-8	Flat Washer 14	2
39	TH114-7	Hex Thin Nut M14	2
40	TH114-51	Drain Plug	1
41	TH114-50	Washer Groupware 16	1
42	TH155-42	Valve Sleeve	1
43	TH155-43	O-ring 10x2	5
44	TH155-44	Adjusting Screw M5x8	1
45	TH114-40	Steel Ball 6	1

PARTS LIST – THLS-6G (1938181001) – Pt 2

Item No.	Handy Part No	Description	Qty
46	TH114-29	Pressure Limited Valve Spring	1
47	TH114-30	Adjusting Screw M8x8	1
48	TH244-6	Log Pusher Connection Weldment	1
49	TH114-52	Plastic Insert 1	1
50	TH114-23	Plastic Insert 2	1
51	TH114-24	Log Pusher	1
52	TH114-25	Nut M10	4
53	TH114-22	Flat Washer 10	5
54	TH114-21	Screw M10x25	4
55	TH114-88GM	Wheel Cap	2
56	TH114-89	Circlip Washer 14	2
57	TH114-90	Wheel	2
58	TH155-58	Big Flat Washer 6	1
59	TH114-39GM	Wheel Bracket Weldment	1
60	TH114-87	Bolt M8x55	6
61	TH155-61	Spring Washer 8	9
62	TH155-62	Washer 8	9
63	TH114-83	Gear Pump Cover	1
64	TH114-64	O-ring 10.6x2.65	2
65	TH114-76	Gear Housing Plate	1
66	TH114-79	Circlip 10	2
67	TH114-80	Gear Shaft	1
68	TH114-78	Steel Ball 2.5	1
69	TH114-77	Pump Gear	2
70	TH155-70	Pin 2.5x4	1
71	TH114-69	Washer 6	1
72	TH114-70	Bolt M5x180	3
73	TH114-71	Motor Cover	1
74	TH114-57	Seal FB11x26x7	1
75	TH114-54	Nut M8	1
76	TH114-55	Screw M8x35	1
77	TH114-65	Motor	1
78	TH155-78	Motor Fan	1
79	TH155-79	Shaft Circlip A17	1
80	TH155-80	Shroud	1
81	TH155-82	Spring Washer 5	6
82	TH155-83	Screw M5x10	3
83	TH244-7	Leg	1
84	TH155-85	Nut M8	5
85	TH114-60	Bolt M8x12	3
86	TH114-65	Cable & Plug	1
87	TH244-8	Bolt M8x16	2
88	TH114-90	Cable Gland Strain Relief Connector	1
89	TH244-9	Washer 5	6
90	TH114-91	Screw M4x10	11
91	TH114-92	Switch Box Cover	1

PARTS LIST – THLS-6G (1938181001) – Pt 3

Item No.	Handy Part No	Description	Qty
92	TH114-93	Airproof Underlay	1
93	TH114-95	Connection Terminal	1
94	TH114-96	Capacitor	1
95	TH114-94	Switch	1
96	TH114-97	Switch Box	1
97	TH114-98	Waterproof Underlay	1
98	TH114-73	Motor Support Left Shoe	1
99	TH114-72	Motor Support Right Shoe	1
100	TH114-75	Pin 8x24	2
101	TH114-82	O-ring 46.2x1.8	2
102	TH114-81	Sliding Sleeve	4
103	TH114-84	Bolt M8x30	3
104	TH244-10	Spring Washer 14	2
105	TH244-11	Screw M6x12	13
106	TH244-12	Guard Bottom Plate	1
107	TH244-13	Locknut M6	17
108	TH244-14	Log Tray 1	1
109	TH244-15	Support Strut 1	2
110	TH244-16	Log Tray 2	1
111	TH244-17	Support Strut 2	1
112	TH244-18	Top Guard Plate 2	1
113	TH244-19	Screw M5x12	20
114	TH244-20	Locknut M5	20
115	TH244-21	Plate connector	2
116	TH244-22	Top Guard Plate 1	1
117	TH244-23	Left Guard Plate	1
118	TH244-24	Rear Guard Plate 2	1
119	TH244-25	Rear Guard Plate 1	1
120	TH244-26	Front Guard Plate	1
121	TH114-105	Ram Stopper	1
122	TH114-106	Ram Stopper 3-Star Screw	1

GJ HANDY & CO LTD USER WARRANTY POLICY

Users Statement of Warranty

Each new machine is warranted against defective material or assembly of material under normal usage. The warranty applies to the original purchaser and covers faulty parts and the labour involved in replacing and repairing those parts, which are of original manufacture.

Period of Warranty

Webb (excludes Electric Handheld & Dynamic), Webb Pro, Sanli Engine

- a) 2 years from the original date of sale to the first domestic user.
- b) 90 days from the original date of sale to the professional/commercial user.
- c) 90 days from the original date of sale when used for hire.
- d) A reduced warranty period of 90 days applies to those items which are subject to normal wear and tear (e.g. but not limited to wheels, tyres, cutter bars, cylinders, cutting blades, blade boss, belts, cables, nylon line & spool, collection bags, spark plugs).
- e) Engines are supplied with a separate warranty to the machine. The engine manufacturers warranty statement which will be supplied within the engine instruction manual. All enquiries and warranty repairs should be discussed with the engine manufacturer or approved warranty repair dealer.
- f) 90 days from the original date of purchase for Replacement Spare Parts (unless normal wear & tear component, which are covered for 30 days).
- g) All machines' must be serviced within the first 12 months from the original date of purchase to comply with the warranty, failure to do so will invalidate the 2nd year of the warranty.

All warranty repairs must be undertaken by an authorised service dealer. These dealers have been accredited by GJ Handy & Co Ltd and agree to only use genuine parts and follow our repair procedures.

Webb Electric Handheld, Webb Dynamic, Handy, Mowerland, Q-Garden

- a) 1 year from the original date of sale to the first domestic user.
- b) 90 days from the original date of sale to the professional/commercial user.
- c) 90 days from the original date of sale when used for hire.
- d) A reduced warranty period of 90 days applies to those items which are subject to normal wear and tear (e.g. but not limited to wheels, tyres, cutter bars, cylinders, cutting blades, blade boss, belts, cables, nylon line & spool, collection bags, spark plugs).
- e) Engines are supplied with a separate warranty to the machine. The engine manufacturers warranty statement which will be supplied within the engine instruction manual. All enquiries and warranty repairs should be discussed with the engine manufacturer or approved warranty repair dealer.
- f) 90 days from the original date of purchase for Replacement Spare Parts (unless normal wear & tear component, which are covered for 30 days).

All warranty repairs must be undertaken by an authorised service dealer. These dealers have been accredited by GJ Handy & Co Ltd and agree to only use genuine parts and follow our repair procedures.

Version 06 (01-18)

GJ HANDY & CO LTD USER WARRANTY POLICY

Not covered by this warranty

- a) The warranty policy does not cover any depreciation or damages caused by ordinary wear, rusting or corrosion, lack of correct maintenance or operation, misuse, abuse, lack of transportation or accident.
- b) The warranty policy does not cover any costs necessary for the standard periodic maintenance services instructed by the operator's manual, or service parts replacement which would include oil, filters, tyres, belts, brake linings, fuses, blades, seals and other service parts unless it can be proven that the item has evidence of faulty manufacture.
- c) The warranty policy will not cover failure or damage caused as a result of parts or accessories being modified without the written approval of GJ Handy & Co Ltd.
- d) The warranty policy will not cover the unit if non-genuine parts have been fitted and as a result damage has occurred to the unit.
- e) The warranty policy is non-transferable and is only applicable to the original purchaser.

Disclaimer

- a) This warranty is only a remedy for defect of products. GJ Handy & Co Ltd will never warranty in terms of the merchantability or the fitness for a particular purpose.
- b) No person is authorised to make any warranties, representations or promises, expressed or implied, on behalf of GJ Handy & Co Ltd, or to modify the terms conditions or limitation of this warranty policy in any way.
- c) Neither GJ Handy & Co Ltd nor any company affiliated with GJ Handy & Co Ltd shall be liable in any event or manner whatsoever for incidental or consequential damages or injuries, including, but not limited to, loss of crops, loss of profit, out of pocket expenses or profits, rental of substitute equipment or other commercial losses.

General

- a) Most warrantable failures show up within the first few weeks of use. These failures are usually straightforward and warranty assessment is relatively easy.
- b) Failures relating to cutter decks and belts need careful investigation, as the cause may not always be straightforward. Look for damage to blades and pulleys especially when the cutter belt or blade boss have snapped or cracked as this could be due to impact damage.
- c) Customers should always refer to the operator/instruction manual when any disputed problem arises, you will find most areas covered within the manual.

Version 06 (01-18)

**For spares or support of your handy product,
please contact us:**

Tel: 01793 333212

**Email: customerservice@handydistribution.co.uk
(Mon – Fri 8.00am to 5.30pm excl. Bank Holidays)**

To see our range of garden machinery & equipment visit:

www.thehandy.co.uk

Making gardening easier & affordable since 1938

Distributed by Handy Distribution, Murdock Road, Dorcan, Swindon, SN3 5HY